Testing of concrete —
Part 4:
Strength of hardened concrete

Essais du béton —

Partie 4: Résistance du béton durci

iTeh STANDARD PREVIEW
(standards.iteh.ai)

ISO 1920-4:2020

<https://standards.iteh.ai/catalog/standards/sist/2c2b6081-d6a1-4d3f-b6dd-40433e380fca/iso-1920-4-2020>



iTeh STANDARD PREVIEW (standards.iteh.ai)

ISO 1920-4:2020

<https://standards.iteh.ai/catalog/standards/sist/2c2b6081-d6a1-4d3f-b6dd-40433e380fca/iso-1920-4-2020>



COPYRIGHT PROTECTED DOCUMENT

© ISO 2020

All rights reserved. Unless otherwise specified, or required in the context of its implementation, no part of this publication may be reproduced or utilized otherwise in any form or by any means, electronic or mechanical, including photocopying, or posting on the internet or an intranet, without prior written permission. Permission can be requested from either ISO at the address below or ISO's member body in the country of the requester.

ISO copyright office
CP 401 • Ch. de Blandonnet 8
CH-1214 Vernier, Geneva
Phone: +41 22 749 01 11
Fax: +41 22 749 09 47
Email: copyright@iso.org
Website: www.iso.org

Published in Switzerland

Contents

| | Page |
|---|-----------|
| Foreword | iv |
| 1 Scope | 1 |
| 2 Normative references | 1 |
| 3 Terms and definitions | 1 |
| 4 Determination of compressive strength | 1 |
| 4.1 Test specimens..... | 1 |
| 4.2 Apparatus..... | 2 |
| 4.3 Age at test..... | 2 |
| 4.4 Number of specimens..... | 2 |
| 4.5 Procedure..... | 2 |
| 4.5.1 Preparation and positioning of specimens..... | 2 |
| 4.5.2 Loading..... | 3 |
| 4.5.3 Assessment of type of failure..... | 3 |
| 4.6 Test results..... | 6 |
| 4.7 Test report..... | 6 |
| 5 Determination of flexural strength | 6 |
| 5.1 Test specimens..... | 6 |
| 5.2 Age at test..... | 6 |
| 5.3 Number of specimens..... | 6 |
| 5.4 Apparatus..... | 7 |
| 5.5 Force application..... | 7 |
| 5.6 Procedures..... | 8 |
| 5.6.1 Preparation and positioning of specimens..... | 8 |
| 5.6.2 Loading..... | 9 |
| 5.6.3 Assessment of type of fracture..... | 9 |
| 5.7 Test results..... | 10 |
| 5.8 Test report..... | 11 |
| 6 Determination of tensile splitting strength | 11 |
| 6.1 Specimens..... | 11 |
| 6.2 Apparatus..... | 11 |
| 6.3 Age at test..... | 13 |
| 6.4 Number of specimens..... | 13 |
| 6.5 Procedure..... | 13 |
| 6.5.1 Condition of specimen at the time of testing:..... | 13 |
| 6.5.2 Marking..... | 13 |
| 6.5.3 Specimen positioning..... | 14 |
| 6.5.4 Loading..... | 14 |
| 6.5.5 Examination of specimen..... | 14 |
| 6.6 Test results..... | 15 |
| 6.7 Test report..... | 15 |
| 7 Test report | 15 |
| Annex A (informative) Precision data for measurements of compressive strength | 17 |
| Annex B (normative) Adjustment of test specimens for the compressive strength test | 18 |
| Annex C (informative) Examples of test reports | 27 |
| Bibliography | 30 |

Foreword

ISO (the International Organization for Standardization) is a worldwide federation of national standards bodies (ISO member bodies). The work of preparing International Standards is normally carried out through ISO technical committees. Each member body interested in a subject for which a technical committee has been established has the right to be represented on that committee. International organizations, governmental and non-governmental, in liaison with ISO, also take part in the work. ISO collaborates closely with the International Electrotechnical Commission (IEC) on all matters of electrotechnical standardization.

The procedures used to develop this document and those intended for its further maintenance are described in the ISO/IEC Directives, Part 1. In particular, the different approval criteria needed for the different types of ISO documents should be noted. This document was drafted in accordance with the editorial rules of the ISO/IEC Directives, Part 2 (see www.iso.org/directives).

Attention is drawn to the possibility that some of the elements of this document may be the subject of patent rights. ISO shall not be held responsible for identifying any or all such patent rights. Details of any patent rights identified during the development of the document will be in the Introduction and/or on the ISO list of patent declarations received (see www.iso.org/patents).

Any trade name used in this document is information given for the convenience of users and does not constitute an endorsement.

For an explanation of the voluntary nature of standards, the meaning of ISO specific terms and expressions related to conformity assessment, as well as information about ISO's adherence to the World Trade Organization (WTO) principles in the Technical Barriers to Trade (TBT), see www.iso.org/iso/foreword.html.

This document was prepared by Technical Committee ISO/TC 71, *Concrete, reinforced concrete and pre-stressed concrete*, Subcommittee SC 1, *Test methods for concrete*.

This second edition cancels and replaces the first edition (ISO 1920-4:2005), which has been technically revised.

The main changes compared to the previous edition are as follows:

- the requirements for compressive testing machine have been included and defined;
- the testing age and number of specimens that need to be tested have been included and defined;
- the subclause on loading (see 5.6.2) has been updated.

A list of all parts in the ISO 1920 series can be found on the ISO website.

Any feedback or questions on this document should be directed to the user's national standards body. A complete listing of these bodies can be found at www.iso.org/members.html.

Testing of concrete —

Part 4: Strength of hardened concrete

1 Scope

This document specifies procedures for testing the strength of hardened concrete.

2 Normative references

The following documents are referred to in the text in such a way that some or all of their content constitutes requirements of this document. For dated references, only the edition cited applies. For undated references, the latest edition of the referenced document (including any amendments) applies.

ISO 48-2, *Rubber, vulcanized or thermoplastic — Determination of hardness — Part 2: Hardness between 10 IRHD and 100 IRHD*

ISO 679, *Cement — Test methods — Determination of strength*

ISO 1920-3, *Testing of concrete — Part 3: Making and curing test specimens*

ISO 1920-6, *Testing of concrete — Part 6: Sampling, preparing and testing of concrete cores*

ISO 2781, *Rubber, vulcanized or thermoplastic — Determination of density*

ISO 3310-1, *Test sieves — Technical requirements and testing — Part 1: Test sieves of metal wire cloth*

ISO 4662, *Rubber, vulcanized or thermoplastic — Determination of rebound resilience*

EN 316, *Wood fiberboards — Definition, classification and symbols*

3 Terms and definitions

No terms and definitions are listed in this document.

ISO and IEC maintain terminological databases for use in standardization at the following addresses:

- ISO Online browsing platform: available at <https://www.iso.org/obp>
- IEC Electropedia: available at <http://www.electropedia.org/>

4 Determination of compressive strength

4.1 Test specimens

The test specimen shall be:

- a cube or a cylinder in accordance with ISO 1920-3; or
- cores in accordance with ISO 1920-6.

Damaged specimens shall not be tested.

Specimens that are badly honeycombed and cracked shall not be regarded as being representative of the quality of concrete supplied. In general, standard cube and cylinder specimens should not be tested if they are badly honeycombed as this is an indication of poor specimen making. When such specimens are tested, the test report shall include the fact that the specimen was honeycombed.

Where the designated size, l_1 or l_2 , of the cross-section is outside the tolerances, the specimens may be used for testing by using the actual dimensions; see 4.6.

Where the dimensions or shape of a test specimen exceed the respective tolerances given in ISO 1920-3, the specimen shall be rejected or adjusted (if feasible) by one or more of the following methods:

- uneven surfaces levelled by grinding or by capping;
- the deviation of angles corrected by cutting and/or grinding.

The procedures given in Annex B shall be used to adjust the specimen.

Adjustment by grinding shall be the reference method.

4.2 Apparatus

The test shall be carried out using the following:

4.2.1 A compression-testing machine, robust, related to the size of specimen and capable of providing the rate of loading with minimum desired specifications as mentioned in 4.5.1 and 4.5.2. It shall be in calibration at the time of test. The calibration shall be carried out at least once per year.

Accuracy of the test machine shall be such that the percentage error for the loads within proposed range of use of the machine and shall not exceed $\pm 1,0$ % of the indicated load.

The compression testing machine shall be provided with a control system. The control system may be operated either by manual or automatic means. If the machine is not equipped with automatic application of force, a pacer shall be fitted to enable the operator to maintain the specified rate. The pacer shall indicate a rate within $\pm 5,0$ % of the specified rate.

4.2.2 Machine platens and auxiliary platens, with a hardness value at least 550 HV (Vickers Hardness).

The thickness of the auxiliary platens shall be at least 23 mm. The roughness value, R_a , for the surface texture of the contact faces of the auxiliary platen shall be between 0,4 μm and 3,2 μm .

4.3 Age at test

Tests shall be made at recognized ages of the test specimens, the most usual being 7 days and 28 days. Test at other ages can be performed as per the requirement. The ages shall be calculated from the time water is added to the dry ingredients.

4.4 Number of specimens

At least three specimens, preferably from different batches, shall be made for testing at each selected age.

4.5 Procedure

4.5.1 Preparation and positioning of specimens

For specimens stored in water, excess moisture shall be wiped from the surface of the specimen before placing them in the testing machine. The dimensions of the specimens shall be measured to the nearest 0,2 mm and their weight shall be noted before testing.

The time between the extraction of the specimen from the humidity chamber or the water tank until the test shall be as short as possible and no more than 2 h. The specimen shall be protected from drying while it is outside the humidity chamber or water tank (e.g. by covering with wet burlap).

All testing-machine bearing surfaces shall be wiped clean and any loose grit or other extraneous material shall be removed from the surfaces of the specimen that will be in contact with the platens.

Do not use packing, other than auxiliary platens or spacing blocks, between the specimen and the platens of the testing machine.

Cube specimens shall be compressed perpendicularly to the direction of casting.

The specimen shall be centred on the lower platen to an accuracy of 1 % of the designated size of cubic or diameter of cylindrical specimens.

Where physical means of ensuring centring are provided on the testing machine, and they are in calibration, they shall be deemed to satisfy the requirements for accuracy of centring.

If auxiliary platens are used, the top auxiliary platen shall be aligned with the top of the specimen.

With two-column testing machines, cubic specimens should be placed with the trowelled surface facing a column.

4.5.2 Loading

The load shall be applied without shock and shall be increased continuously at a constant rate until no greater load can be sustained. Select a constant rate of loading within the range $0,6 \text{ MPa/s} \pm 0,2 \text{ MPa/s}$. After the application of the initial load, which does not exceed approximately 30 % of the failure load, apply the load to the specimen without shock and increase continuously at the selected constant rate $\pm 10 \%$, until no greater load can be sustained.

When using manually controlled testing machines, any tendency for the selected rate of loading to decrease as specimen failure is approached shall be corrected by appropriate adjustment of the controls.

When using automatically controlled testing machines, the rate of loading while testing concrete specimens in compression shall be periodically checked to ensure that it is constant.

The maximum load indicated shall be recorded.

4.5.3 Assessment of type of failure

For cubic specimens, if the failure is satisfactory (see [Figure 1](#)), this fact shall be recorded. If the failure pattern is unsatisfactory, this fact shall also be recorded, as well as the type of failure recorded with reference to pattern number according to [Figure 2](#) closest to that observed.

For cylindrical specimens, if the failure is satisfactory (see [Figure 3](#)), this fact shall be recorded. If the failure pattern is unsatisfactory, this fact shall also be recorded, as well as the type of failure recorded with reference pattern letter in [Figure 4](#) closest to that observed.

NOTE Unsatisfactory failures can be caused by insufficient attention to the detailed procedures for making, capping and testing specimens or by a machine fault.

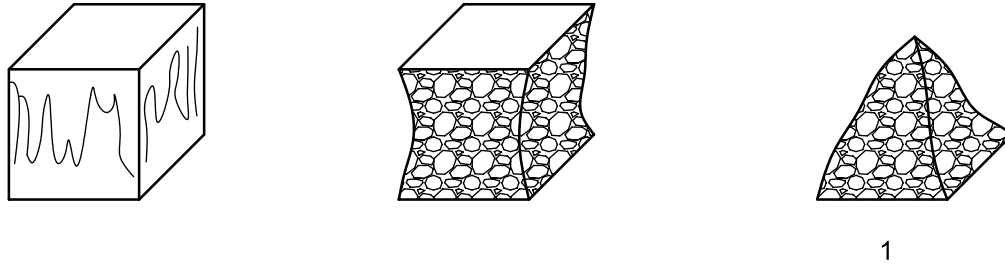

Key

1 explosive failure

NOTE All four exposed faces are cracked approximately equally, generally with little damage to faces in contact with the platens.

Figure 1 — Satisfactory failures of cube specimens

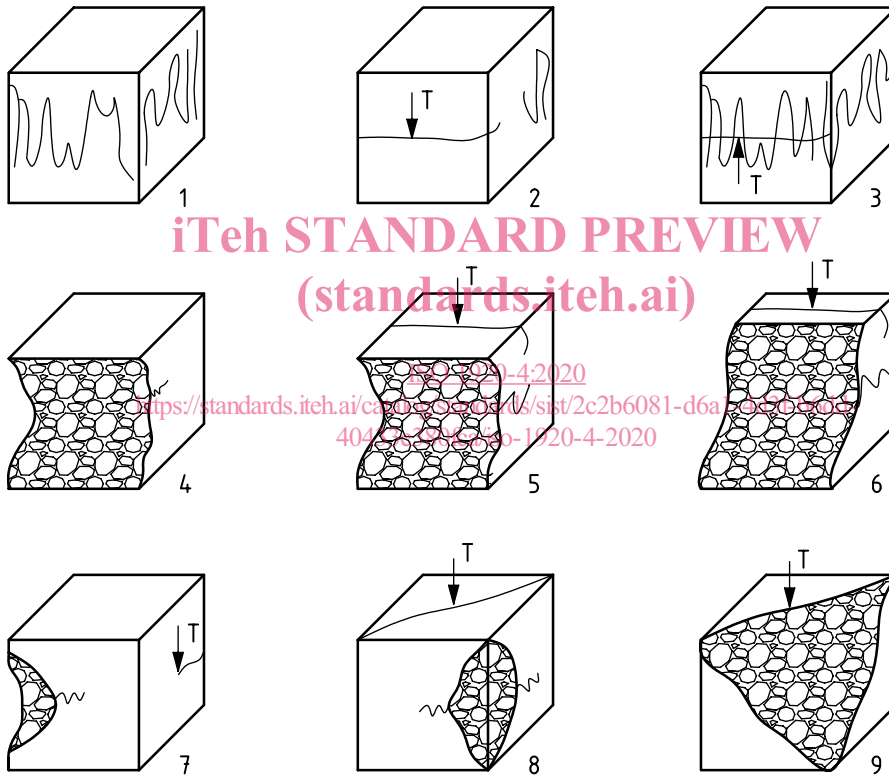

Key

T tensile crack

Figure 2 — Some unsatisfactory failures due to unequal cracking of the exposed faces of cube specimens

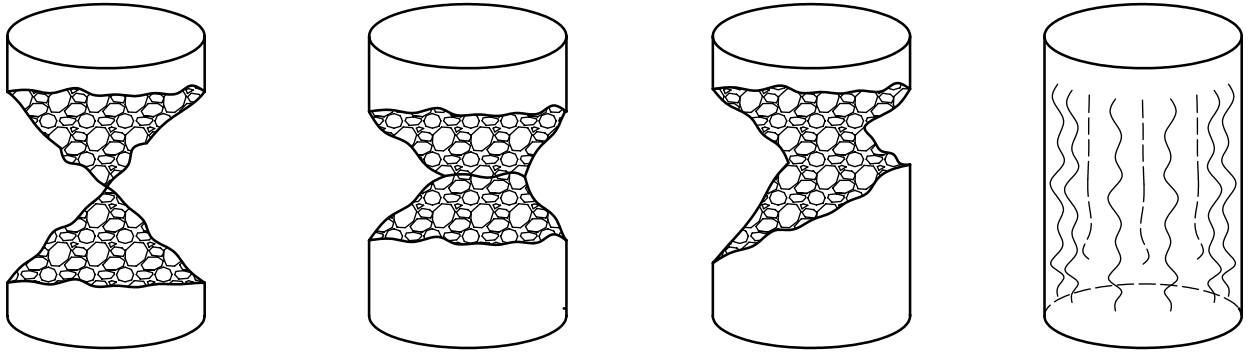

Figure 3 — Satisfactory failure of cylinder specimen

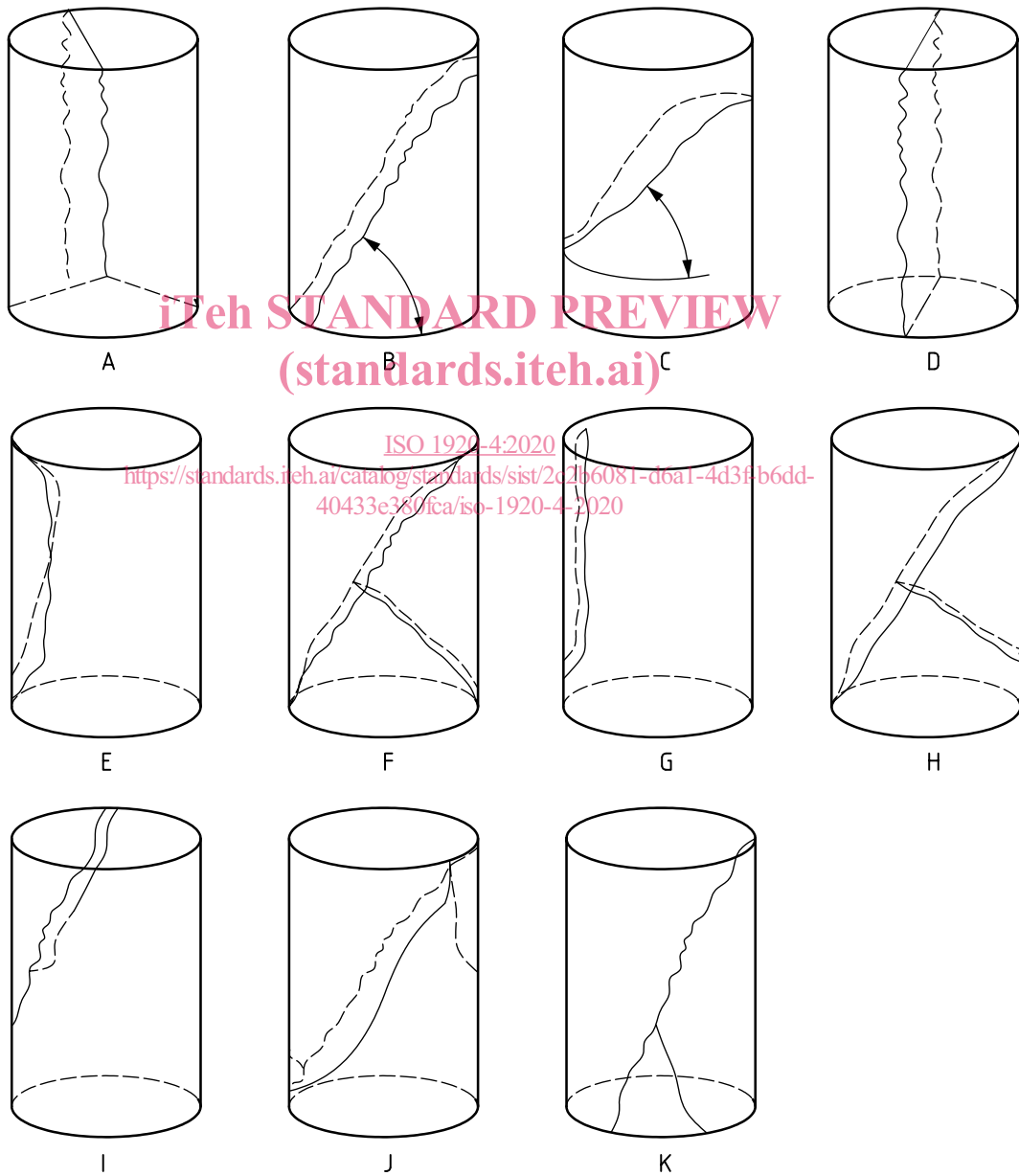

Figure 4 — Unsatisfactory failures of cylinder specimens

4.6 Test results

The compressive strength is given by [Formula \(1\)](#):

$$f_c = \frac{F}{A_c} \quad (1)$$

where

f_c is the compressive strength, expressed in megapascals;

F is the maximum load, expressed in newtons;

A_c is the cross-sectional area, expressed in square millimetres, of the specimen on which the compressive force acts.

If the actual dimensions of the test specimen are within $\pm 0,5\%$ of the designated size, the strength may be calculated on the basis of the designated size. If the actual dimensions are outside this tolerance, the strength calculation shall be based on the actual dimensions of the test specimen, determined in accordance with ISO 1920-3.

The compressive strength shall be expressed to the nearest 0,1 MPa.

NOTE Refer to informative [Annex A](#), for precision data for measurements of compressive strength.

4.7 Test report

iTeh STANDARD PREVIEW

(standards.iteh.ai)

In addition to the requirements in [Clause 7](#), the test report shall include the following:

- type of specimen: cube, cylinder or core; [ISO 1920-4:2020](#)
- method of adjustment, if relevant, <https://standards.iteh.ai/catalog/standards/sist/2c2b6081-d6a1-4d3f-b6dd-40433e380fca/iso-1920-4-2020>
- compressive strength of specimen (to the nearest 0,1 MPa);
- type of failure (satisfactory or unsatisfactory, and, if unsatisfactory, the nearest type).

5 Determination of flexural strength

5.1 Test specimens

The test specimen shall be a prism conforming to ISO 1920-3.

Sawn specimens of nominal size, l , of 100 mm or 150 mm with a square cross-section and overall length, L , of between $4l$ and $5l$ may also be tested as presented in this document. The ratio of l to the maximum size of aggregate shall be no less than four, except for specimens with a nominal width of 150 mm and a maximum size of aggregate of 40 mm, which may also be tested.

The direction of casting shall be identified on the specimen.

5.2 Age at test

Tests shall be made at recognized ages of the test specimens, the most usual being 7 and 28 days. Test at other ages can be performed as per requirement. The ages shall be calculated from the time of the addition of water to the dry ingredients.

5.3 Number of specimens

At least three specimens, preferably from different batches, shall be made for testing at each selected age.

5.4 Apparatus

The test shall be carried out using the following:

5.4.1 Compression-testing machine, robust, related to the size of specimen and capable of providing the rate of loading with minimum desired specifications in 5.4 and 5.5. It shall be in calibration at the time of test. The calibration shall be carried out at least once per year.

Accuracy of the test machine shall be such that the percentage error for the loads within proposed range of use of the machine and shall not exceed $\pm 1,0$ % of the indicated load.

The compression testing machine shall be provided with a control system. The control system may be operated either by manual or automatic means. If the machine is not equipped with automatic application of force, a pacer shall be fitted to enable the operator to maintain the specified rate. The pacer shall indicate a rate within $\pm 5,0$ % of the specified rate.

5.4.2 Machine platens and auxiliary platens, with a hardness value of at least 550 HV (Vickers Hardness).

The thickness of the auxiliary platens shall be at least 23 mm. The roughness value, R_a , for the surface texture of the contact faces of the auxiliary platen shall be between 0,4 μm and 3,2 μm .

5.5 Force application

The device for applying loads shall consist of two upper rollers and two lower rollers (see Figure 5).

All rollers shall be manufactured from steel and shall have a circular cross-section with a diameter between 20 mm and 40 mm and shall be at least 10 mm longer than the width of the test specimen.

Each roller, except one of the lower ones, shall be capable of rotating around its axis and of being inclined in a plane normal to the longitudinal axis of the test specimen.

The distance, L_{rol} , between the lower (outer) rollers (i.e. the span) shall be equal to $3l$, where l is the width of the specimen. The distance between the upper (inner) rollers shall be equal to l . The inner rollers shall be equally spaced between the outer rollers as shown in Figure 5. All rollers shall be adjusted in the positions illustrated in Figure 5 to an accuracy of ± 2 mm.

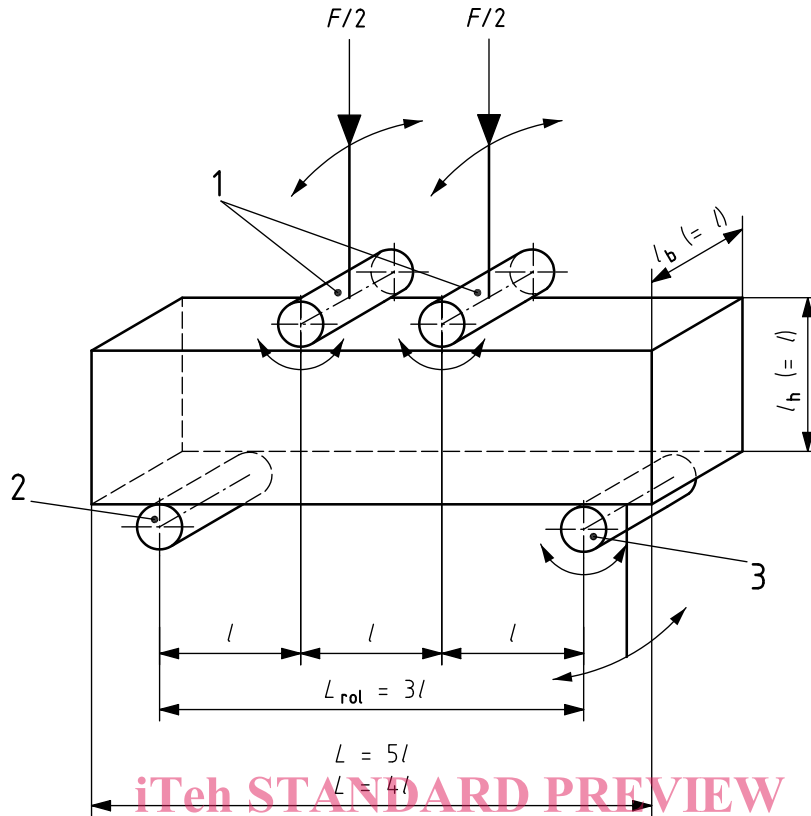

Key

- 1 loading roller (capable of rotation and of being inclined)
- 2 supporting roller
- 3 supporting roller (capable of rotation and of being inclined)
- F maximum load

iTeh STANDARD PREVIEW
(standards.iteh.ai)

ISO 1920-4:2020

<http://standards.iteh.ai/catalog/standards/sist/2c2b6081-d6a1-4d3f-b6dd-40433e380fca/iso-1920-4-2020>

Figure 5 — Arrangement for loading a test specimen (two-point loading)

5.6 Procedures

5.6.1 Preparation and positioning of specimens

The specimen shall be examined and any abnormalities shall be reported.

For specimens stored in water, excess moisture shall be wiped from the surface of the specimen before placing in the testing machine.

The time between the extraction of the specimen from the humidity chamber or the water tank until the test shall be as short as possible and no more than 2 h. The specimen shall be protected from drying while it is outside the humidity chamber or water tank (e.g. by covering with wet burlap).

All testing-machine bearing surfaces shall be wiped clean and any loose grit or other extraneous material shall be removed from the surfaces of the specimen that will be in contact with the rollers.

The test specimen shall be placed in the machine, correctly centred with the longitudinal axis of the specimen at right angles to the longitudinal axis of the upper and lower rollers.

The reference direction of loading shall be perpendicular to the direction of casting of the specimen.

The test result may be affected by the direction of loading with respect to the direction of casting.