

# ETSI TS 102 232-5 V3.21.1 (2024-07)



**Lawful Interception (LI);  
Handover Interface and  
Service-Specific Details (SSD) for IP delivery;  
Part 5: Service-specific details for IP Multimedia services**

[ETSI TS 102 232-5 V3.21.1 \(2024-07\)](https://standards.iteh.ai/catalog/standards/etsi/145931ee-686e-455f-ba9f-76cc3c6ee5ab/etsi-ts-102-232-5-v3-21-1-2024-07)

<https://standards.iteh.ai/catalog/standards/etsi/145931ee-686e-455f-ba9f-76cc3c6ee5ab/etsi-ts-102-232-5-v3-21-1-2024-07>



---

**Reference**

RTS/LI-00261-5

---

**Keywords**

IMS, IP, lawful interception, security

**ETSI**

650 Route des Lucioles  
F-06921 Sophia Antipolis Cedex - FRANCE

Tel.: +33 4 92 94 42 00 Fax: +33 4 93 65 47 16

Siret N° 348 623 562 00017 - APE 7112B  
Association à but non lucratif enregistrée à la  
Sous-Préfecture de Grasse (06) N° w061004871

---

**Important notice**

The present document can be downloaded from the  
ETSI [Search & Browse Standards](#) application.

The present document may be made available in electronic versions and/or in print. The content of any electronic and/or print versions of the present document shall not be modified without the prior written authorization of ETSI. In case of any existing or perceived difference in contents between such versions and/or in print, the prevailing version of an ETSI deliverable is the one made publicly available in PDF format on [ETSI deliver](#).

Users should be aware that the present document may be revised or have its status changed,  
this information is available in the [Milestones listing](#).

If you find errors in the present document, please send your comments to  
the relevant service listed under [Committee Support Staff](#).

If you find a security vulnerability in the present document, please report it through our  
[Coordinated Vulnerability Disclosure \(CVD\)](#) program.

---

**Notice of disclaimer & limitation of liability**

The information provided in the present deliverable is directed solely to professionals who have the appropriate degree of experience to understand and interpret its content in accordance with generally accepted engineering or other professional standard and applicable regulations.

No recommendation as to products and services or vendors is made or should be implied.

No representation or warranty is made that this deliverable is technically accurate or sufficient or conforms to any law and/or governmental rule and/or regulation and further, no representation or warranty is made of merchantability or fitness for any particular purpose or against infringement of intellectual property rights.

In no event shall ETSI be held liable for loss of profits or any other incidental or consequential damages.

Any software contained in this deliverable is provided "AS IS" with no warranties, express or implied, including but not limited to, the warranties of merchantability, fitness for a particular purpose and non-infringement of intellectual property rights and ETSI shall not be held liable in any event for any damages whatsoever (including, without limitation, damages for loss of profits, business interruption, loss of information, or any other pecuniary loss) arising out of or related to the use of or inability to use the software.

---

**Copyright Notification**

No part may be reproduced or utilized in any form or by any means, electronic or mechanical, including photocopying and microfilm except as authorized by written permission of ETSI.

The content of the PDF version shall not be modified without the written authorization of ETSI.

The copyright and the foregoing restriction extend to reproduction in all media.

© ETSI 2024.  
All rights reserved.

# Contents

Intellectual Property Rights .....	5
Foreword.....	5
Modal verbs terminology.....	5
Introduction .....	5
1 Scope .....	6
2 References .....	6
2.1 Normative references .....	6
2.2 Informative references.....	7
3 Definition of terms, symbols and abbreviations.....	8
3.1 Terms.....	8
3.2 Symbols.....	8
3.3 Abbreviations .....	8
4 General .....	10
4.1 Reference Model for Lawful Interception .....	10
4.2 Reference system model.....	11
4.2.0 Overview .....	11
4.2.1 Network layer Interception .....	12
4.2.2 Service layer Interception .....	12
4.3 General Requirements .....	13
5 Interception of IP Multimedia services .....	13
5.1 Identification of target of interception.....	13
5.1.1 SIP Target Identification.....	13
5.1.2 H.323 Target Identification.....	14
5.1.3 Other Target Identifiers .....	14
5.2 Interception of signalling.....	14
5.2.1 Provisioning of the SIP IRI IIF.....	14
5.2.2 Provisioning of the H.323 IRI IIF.....	14
5.2.3 Location information .....	14
5.2.4 Supplementary Services.....	14
5.2.5 Additional signalling information.....	15
5.2.6 SIP Messages in IRI-only intercept .....	15
5.2.6.1 General .....	15
5.2.6.2 SMS Messages .....	15
5.2.7 Signalling IP address information.....	16
5.3 Assigning a value to the Communication Identity Number .....	17
5.3.0 Introduction.....	17
5.3.1 Assigning a CIN value to SIP related IRI .....	17
5.3.2 Assigning a CIN value to H.323 related IRI .....	17
5.3.3 Assigning a CIN value to XCAP related IRI .....	17
5.4 Events and IRI record types .....	17
5.5 Interception of Content of Communication.....	18
5.6 Direction for IMS IRI for Signalling Messages .....	19
5.7 Direction for IMS sessions .....	19
5.7.1 Direction for SIP sessions.....	19
5.7.2 Direction for H.323 sessions.....	19
5.8 Correlation of signalling and media .....	19
6 Handover Interface .....	20
6.1 Intercept Related Information.....	20
6.2 Correlation of IRI and CC .....	20
7 ASN.1 specification for IRI and CC.....	20
<b>Annex A (informative): Interception using H.248 .....</b>	<b>21</b>

A.1	Purpose of this annex .....	21
A.2	Notes on interception using H.248 .....	21
A.2.1	Target identification (see also clause 5.1) .....	21
A.2.2	Provisioning of the H.248 IRI IIF (see also clause 5.2) .....	22
A.3	Problems in H.248 interception.....	22
A.3.1	Missing information in H.248 signalling.....	22
A.3.2	Missing call content.....	23
<b>Annex B (normative): Minimum set of functional attributes to be provided.....</b>		<b>24</b>
B.0	Overview .....	24
B.1	General requirements .....	24
B.2	Result of interception .....	25
B.3	Location information.....	25
B.4	Time constraints .....	25
B.5	Technical handover interfaces and format requirements.....	26
<b>Annex C (informative): Change request history.....</b>		<b>27</b>
History .....		30

iTech Standards  
 (<https://standards.iteh.ai>)  
 Document Preview

[ETSI TS 102 232-5 V3.21.1 \(2024-07\)](https://standards.iteh.ai/catalog/standards/etsi/145931ee-686e-455f-ba9f-76cc3c6ee5ab/etsi-ts-102-232-5-v3-21-1-2024-07)

<https://standards.iteh.ai/catalog/standards/etsi/145931ee-686e-455f-ba9f-76cc3c6ee5ab/etsi-ts-102-232-5-v3-21-1-2024-07>

---

# Intellectual Property Rights

## Essential patents

IPRs essential or potentially essential to normative deliverables may have been declared to ETSI. The declarations pertaining to these essential IPRs, if any, are publicly available for **ETSI members and non-members**, and can be found in ETSI SR 000 314: "*Intellectual Property Rights (IPRs); Essential, or potentially Essential, IPRs notified to ETSI in respect of ETSI standards*", which is available from the ETSI Secretariat. Latest updates are available on the ETSI Web server (<https://ipr.etsi.org/>).

Pursuant to the ETSI Directives including the ETSI IPR Policy, no investigation regarding the essentiality of IPRs, including IPR searches, has been carried out by ETSI. No guarantee can be given as to the existence of other IPRs not referenced in ETSI SR 000 314 (or the updates on the ETSI Web server) which are, or may be, or may become, essential to the present document.

## Trademarks

The present document may include trademarks and/or tradenames which are asserted and/or registered by their owners. ETSI claims no ownership of these except for any which are indicated as being the property of ETSI, and conveys no right to use or reproduce any trademark and/or tradename. Mention of those trademarks in the present document does not constitute an endorsement by ETSI of products, services or organizations associated with those trademarks.

**DECT™**, **PLUGTESTS™**, **UMTS™** and the ETSI logo are trademarks of ETSI registered for the benefit of its Members. **3GPP™** and **LTE™** are trademarks of ETSI registered for the benefit of its Members and of the 3GPP Organizational Partners. **oneM2M™** logo is a trademark of ETSI registered for the benefit of its Members and of the oneM2M Partners. **GSM®** and the GSM logo are trademarks registered and owned by the GSM Association.

---

# Foreword

This Technical Specification (TS) has been produced by ETSI Technical Committee Lawful Interception (LI).

The present document is part 5 of a multi-part deliverable. Full details of the entire series can be found in part 1 [2].

The ASN.1 module is available as an electronic attachment to the present document (see clause 7 for details).

---

# Modal verbs terminology

In the present document "**shall**", "**shall not**", "**should**", "**should not**", "**may**", "**need not**", "**will**", "**will not**", "**can**" and "**cannot**" are to be interpreted as described in clause 3.2 of the [ETSI Drafting Rules](#) (Verbal forms for the expression of provisions).

"**must**" and "**must not**" are **NOT** allowed in ETSI deliverables except when used in direct citation.

---

# Introduction

The present document focuses on Lawful Interception of IP Multimedia Services. It is to be used in conjunction with ETSI TS 102 232-1 [2], in which the handling of the intercepted information is described.

---

# 1 Scope

The present document specifies interception of Internet Protocol (IP) Multimedia (MM) Services based on the Session Initiation Protocol (SIP) and Realtime Transport Protocol (RTP) and Message Session Relay Protocol (MSRP) and IP MM services as described by the Recommendations ITU-T H.323 [6] and H.248-1 [i.3].

The present document is consistent with the definition of the Handover Interface, as described in ETSI TS 102 232-1 [2].

The present document does not override or supersede any specifications or requirements in 3GPP TS 33.108 [9] and ETSI TS 101 671 [1].

---

# 2 References

## 2.1 Normative references

References are either specific (identified by date of publication and/or edition number or version number) or non-specific. For specific references, only the cited version applies. For non-specific references, the latest version of the referenced document (including any amendments) applies.

Referenced documents which are not found to be publicly available in the expected location might be found at <https://docbox.etsi.org/Reference>.

NOTE: While any hyperlinks included in this clause were valid at the time of publication, ETSI cannot guarantee their long term validity.

The following referenced documents are necessary for the application of the present document.

- [1] [ETSI TS 101 671](#): "Telecommunications security; Lawful Interception (LI) Handover interface for the lawful interception of telecommunications traffic".

NOTE: ETSI TS 101 671 is in status "historical" and is not maintained.

- [2] [ETSI TS 102 232-1](#): "Lawful Interception (LI); Handover Interface and Service-Specific Details (SSD) for IP delivery; Part 1: Handover specification for IP delivery".

- [3] [Recommendation ITU-T X.680](#): "Information technology - Abstract Syntax Notation One (ASN.1): Specification of basic notation".

- [4] [IETF RFC 3261](#): "SIP: Session Initiation Protocol".

- [5] [IETF RFC 3550](#): "RTP: A Transport Protocol for Real-Time Applications".

- [6] [Recommendation ITU-T H.323](#): "Packet-based multimedia communications systems".

- [7] Void.

- [8] Void.

- [9] [ETSI TS 133 108](#): " Digital cellular telecommunications system (Phase 2+) (GSM); Universal Mobile Telecommunications System (UMTS); LTE; 3G security; Handover interface for Lawful Interception (LI) (3GPP TS 33.108)".

- [10] [ETSI TS 101 331](#): "Lawful Interception (LI); Requirements of Law Enforcement Agencies".

- [11] [ATIS-1000678.v4.2020](#): "Lawfully Authorized Electronic Surveillance (LAES) for Voice over Internet Protocol and Rich Communications Services Messaging in Wireline and Broadband Telecommunications Networks, Version 4".

- [12] [Recommendation ITU-T H.225.0](#): "Call signalling protocols and media stream packetization for packet-based multimedia communication systems".

- [13] [Recommendation ITU-T H.245](#): "Control protocol for multimedia communication".
- [14] Void.
- [15] [IETF RFC 4975](#): "The Message Session Relay Protocol (MSRP)".
- [16] [Recommendation ITU-T T.38](#): "Procedures for real-time Group 3 facsimile communication over IP networks".
- [17] [IETF RFC 4825](#): "The Extensible Markup Language (XML) Configuration Access Protocol (XCAP)".
- [18] [ETSI TS 124 623](#): "Digital cellular telecommunications system (Phase 2+) (GSM); Universal Mobile Telecommunications System (UMTS); LTE; 5G; Extensible Markup Language (XML) Configuration Access Protocol (XCAP) over the Ut interface for Manipulating Supplementary Services (3GPP TS 24.623)".
- [19] [IETF RFC 5322](#): "Internet Message Format".
- [20] [ISO 3166-1](#): "Codes for the representation of names of countries and their subdivisions -- Part 1: Country codes".
- [21] [ETSI TS 123 038](#): "Digital cellular telecommunications system (Phase 2+) (GSM); Universal Mobile Telecommunications System (UMTS); LTE; 5G; Alphabets and language-specific information (3GPP TS 23.038)".
- [22] [ETSI TS 123 040](#): "Digital cellular telecommunications system (Phase 2+) (GSM); Universal Mobile Telecommunications System (UMTS); LTE; 5G; Technical realization of the Short Message Service (SMS) (3GPP TS 23.040)".
- [23] [ETSI TS 133 128](#): "Digital cellular telecommunications system (Phase 2+) (GSM); Universal Mobile Telecommunications System (UMTS); LTE; 5G; Security; Protocol and procedures for Lawful Interception (LI); Stage 3 (3GPP TS 33.128)".

## 2.2 Informative references

References are either specific (identified by date of publication and/or edition number or version number) or non-specific. For specific references, only the cited version applies. For non-specific references, the latest version of the referenced document (including any amendments) applies.

NOTE: While any hyperlinks included in this clause were valid at the time of publication, ETSI cannot guarantee their long term validity.

The following referenced documents are not necessary for the application of the present document but they assist the user with regard to a particular subject area.

- [i.1] ETSI TR 102 528: "Lawful Interception (LI); Interception domain Architecture for IP networks".
- [i.2] ETSI TR 102 503: "Lawful Interception (LI); ASN.1 Object Identifiers in Lawful Interception and Retained data handling Specifications".
- [i.3] Recommendation ITU-T H.248-1: "Gateway control protocol: Version 3".

NOTE: H.248 was renumbered when revised on 2002-03-29. H.248 main body, Annexes A to E and Appendix I were included in H.248.1. Subsequent annexes were sequentially numbered in the series, e.g. H.248 Annex F became H.248.2.

## 3 Definition of terms, symbols and abbreviations

### 3.1 Terms

For the purposes of the present document, the terms given in ETSI TS 101 671 [1], ETSI TS 102 232-1 [2] and the following apply:

**context:** logical collection of H.248 terminations

**IP MultiMedia service:** multimedia service that utilizes the Internet Protocol (IP) for the transport of data

**MultiMedia (MM):** use of computers to present text, graphics, video, animation and sound in an integrated way

**MultiMedia service:** communication service that offers Multimedia communication to end-users

**termination:** entity in H.248 that acts as a source or sink of media

NOTE: Terminations may be physical, such as a given channel on a TDM line, or ephemeral, such as an IP endpoint.

**TSAP identifier:** piece of information used to multiplex several transport connections of the same type on a single H.323 entity with all transport connections sharing the same Network Address (e.g. the port number in a TCP/UDP/IP environment)

NOTE: Transport layer Service Access Point (TSAP) identifiers may be (pre)assigned statically by some international authority or may be allocated dynamically during the setup of a call. Dynamically assigned TSAP identifiers are of transient nature, i.e. their values are only valid for the duration of a single call.

### 3.2 Symbols

Void.

### 3.3 Abbreviations

For the purposes of the present document, the following abbreviations apply:

AF	Administration Function
ASN.1	Abstract Syntax Notation One
CC	Content of Communication
CCCI	Content of Communication Control Interface
CC IIF	CC Internal Interception Function
CCTF	Content of Communication Trigger Function
CCTI	Content of Communication Trigger Interface
CID	Communication IDentifier
CIN	Communication Identity Number
CLI	Calling Line Identity
CSP	Communications Service Provider

NOTE: Covers all AP/NWO/SvP.

DTMF	Dual Tone Multi Frequency
FFS	For Further Study
GSM	Global System for Mobile
GW	GateWay
HI1	Handover Interface 1 (for Administrative Information)
HI2	Handover Interface 2 (for Intercept Related Information)
HI3	Handover Interface 3 (for Content of Communication)
HTTP	Hyper Text Transfer Protocol
ID	IDentity
IF	Interception Function



IIF	Internal Interception Function
IMEI	International Mobile Equipment Identity
IMPI	IMS Private Identity
IMPU	IMS Public identity
IMS	IP Multimedia Subsystem
IMSI	International Mobile Station Identity
INI	Internal Network Interface
IP	Internet Protocol
IRI	Intercept Related Information
IRI IIF	IRI Internal Interception Function
LEA	Law Enforcement Agency
LEMF	Law Enforcement Monitoring Facility
LI	Lawful Interception
LIAF	Lawful Interception Administration Function
LIID	Lawful Interception IDentifier
MF	Mediation Function
MG	Media Gateway
MGC	Media Gateway Controller
MM	MultiMedia
MSRP	Message Session Relay Protocol
NNI	Network-to-Network Interface
OID	Object IDentifier
PDU	Protocol Data Unit
RAS	Registration, Administration and Status
RP	Relay Protocol
RTCP	RTP Control Protocol
RTP	Realtime Transport Protocol
SDP	Session Description Protocol
SIP	Session Initiation Protocol
SMS	Short Message Service
SSD	Service-Specific Details
SvP	Service Provider
TCP	Transmission Control Protocol
TDM	Time Division Multiplex
TP	Transfer Protocol
TPDU	Transaction Protocol Data Unit
TSAP	Transport layer Service Access Point
UDP	User Datagram Protocol
UDPTL	Facsimile UDP Transport Layer (protocol)
UE	User Equipment
UNI	User-Network Interface
URI	Uniform Resource Identifier
URL	Uniform Resource Locator
VoIP	Voice over IP
XCAP	eXtensible Markup Language (XML) Configuration Access Protocol

## 4 General

### 4.1 Reference Model for Lawful Interception

The present document adopts the generic reference model for the interception domain from ETSI TR 102 528 [i.1], its internal intercept functions, Intercept Related Information Internal Interception Function (IRI IIF), Content of Communication Trigger Function (CCTF), and Content of Communication Internal Interception Function (CC IIF), and the Internal Network Interfaces INI1, INI2, INI3, Content of Communication Trigger Interface (CCTI) and Content of Communication Control Interface (CCCI) as shown in Figure 1.

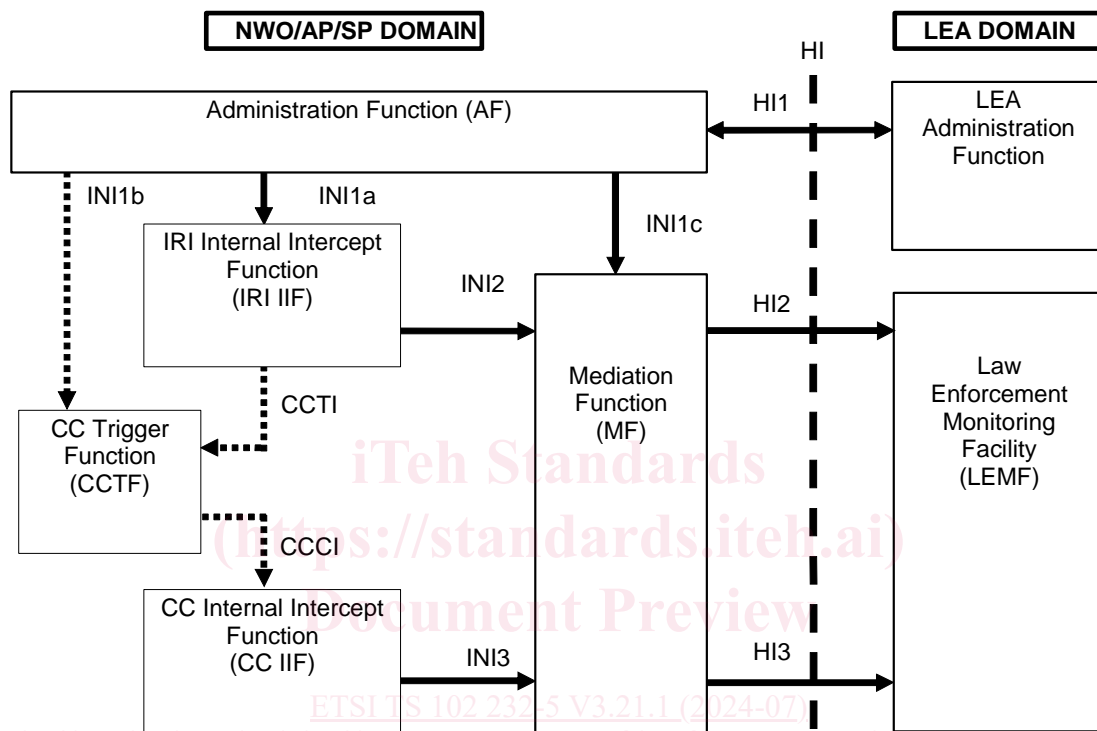

**Figure 1: Reference Model for Lawful Interception**

The reference model depicts the following functions and interfaces:

- INI1a provisions Intercept Related Information Internal Interception Function (IRI IIF).
- INI1b may (statically) provision Content of Communications Trigger Function (CCTF).
- INI1c provisions the Mediation Function (MF).
- Intercept Related Information Internal Interception Function (IRI IIF) generates IRI.
- Content of Communication Internal Interception Function (CC IIF) generates CC.
- Content of Communication Trigger Function (CCTF) controls CC IIF.
- Content of Communication Control Interface (CCCI) provisions CC IIF.
- Content of Communication Trigger Interface (CCTI) may trigger CCTF for provisioning of the CC IIF.
- Content of Communication Control Interface (CCCI) may dynamically provision the CC IIF.
- Internal interface INI1 carries provisioning information from LIAF to the Internal Intercept Functions (IIF).
- Internal interface INI2 carries Intercept Related Information (IRI) from IRI IIF to the MF.
- Internal interface INI3 carries Content of Communication (CC) information from CC IIF to the MF.

For an in-depth explanation of the functions and interface, refer to clause 4 of ETSI TR 102 528 [i.1].

## 4.2 Reference system model

### 4.2.0 Overview

The reference system model applied in the present document, as depicted in Figure 2, provides a simplified model of a technology independent, IP MultiMedia (MM) service platform, accessed by multiple different access networks. The access networks may provide different forms of network access, using different technologies; they all have in common that they provide IP connectivity among end-users and between end-users and the IP MM services provided by the IP MM service platform.

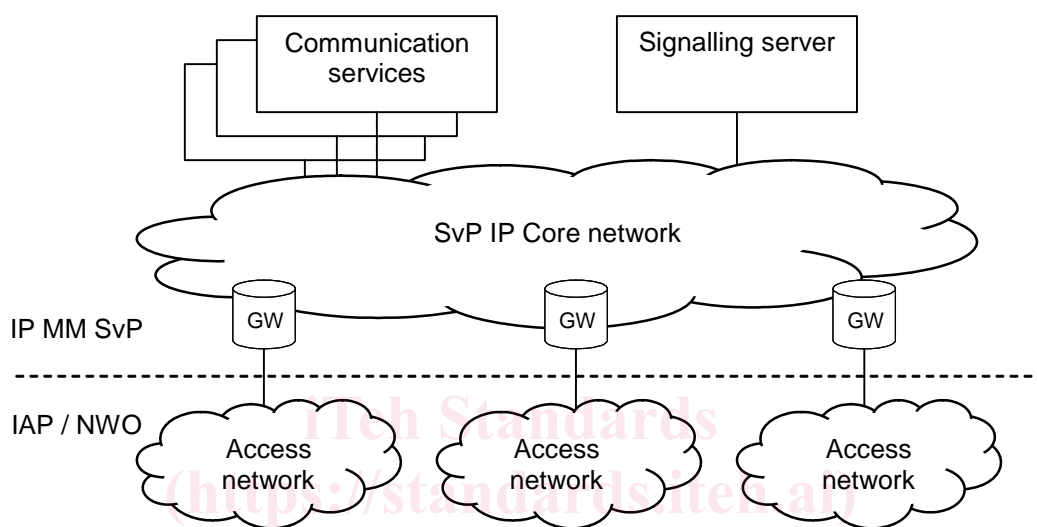

**Figure 2: Reference System Model**

Access from the access networks into the IP Core network of the IP MM service provider is assumed to be protected by some gateway device (e.g. a session border controller, border gateway controller or a firewall/router combination).

The IP MM Service platform contains a signalling server that provides session initiation functionality (e.g. a SIP call manager or an H.323 gatekeeper) among end-users and between end-users and communication services (e.g. unified messaging, audio or video conference servers).