

FINAL
DRAFT

INTERNATIONAL
STANDARD

ISO/FDIS
10545-15

ISO/TC 189

Secretariat: ANSI

Voting begins on:
2021-03-16

Voting terminates on:
2021-05-11

Ceramic tiles —

**Part 15:
Determination of lead and cadmium
given off by tiles**

Carreaux et dalles céramiques —

*Partie 15: Détermination de la teneur en plomb et en cadmium
relargués par les carreaux*
(standards.iteh.ai)

ISO/FDIS 10545-15

<https://standards.iteh.ai/catalog/standards/sist/7c3c3738-7e4d-488a-8599-25fa89cbbec3/iso-fdis-10545-15>

ISO/CEN PARALLEL PROCESSING

RECIPIENTS OF THIS DRAFT ARE INVITED TO SUBMIT, WITH THEIR COMMENTS, NOTIFICATION OF ANY RELEVANT PATENT RIGHTS OF WHICH THEY ARE AWARE AND TO PROVIDE SUPPORTING DOCUMENTATION.

IN ADDITION TO THEIR EVALUATION AS BEING ACCEPTABLE FOR INDUSTRIAL, TECHNOLOGICAL, COMMERCIAL AND USER PURPOSES, DRAFT INTERNATIONAL STANDARDS MAY ON OCCASION HAVE TO BE CONSIDERED IN THE LIGHT OF THEIR POTENTIAL TO BECOME STANDARDS TO WHICH REFERENCE MAY BE MADE IN NATIONAL REGULATIONS.



Reference number
ISO/FDIS 10545-15:2021(E)

© ISO 2021

iTeh STANDARD PREVIEW
(standards.iteh.ai)

[ISO/FDIS 10545-15](https://standards.iteh.ai/catalog/standards/sist/7c3c3738-7e4d-488a-8599-25fa89cbbec3/iso-fdis-10545-15)
<https://standards.iteh.ai/catalog/standards/sist/7c3c3738-7e4d-488a-8599-25fa89cbbec3/iso-fdis-10545-15>



COPYRIGHT PROTECTED DOCUMENT

© ISO 2021

All rights reserved. Unless otherwise specified, or required in the context of its implementation, no part of this publication may be reproduced or utilized otherwise in any form or by any means, electronic or mechanical, including photocopying, or posting on the internet or an intranet, without prior written permission. Permission can be requested from either ISO at the address below or ISO's member body in the country of the requester.

ISO copyright office
CP 401 • Ch. de Blandonnet 8
CH-1214 Vernier, Geneva
Phone: +41 22 749 01 11
Email: copyright@iso.org
Website: www.iso.org

Published in Switzerland

Contents

	Page
Foreword	iv
1 Scope	1
2 Normative references	1
3 Terms and definitions	1
4 Principle	1
5 Reagents	1
5.1 General	1
5.2 Test solution	1
6 Apparatus and materials	2
7 Test specimens	2
8 Procedure	2
9 Expression of results	3
10 Test report	3

iTeh STANDARD PREVIEW (standards.iteh.ai)

[ISO/FDIS 10545-15](#)

<https://standards.iteh.ai/catalog/standards/sist/7c3c3738-7e4d-488a-8599-25fa89cbbec3/iso-fdis-10545-15>

Foreword

ISO (the International Organization for Standardization) is a worldwide federation of national standards bodies (ISO member bodies). The work of preparing International Standards is normally carried out through ISO technical committees. Each member body interested in a subject for which a technical committee has been established has the right to be represented on that committee. International organizations, governmental and non-governmental, in liaison with ISO, also take part in the work. ISO collaborates closely with the International Electrotechnical Commission (IEC) on all matters of electrotechnical standardization.

The procedures used to develop this document and those intended for its further maintenance are described in the ISO/IEC Directives, Part 1. In particular, the different approval criteria needed for the different types of ISO documents should be noted. This document was drafted in accordance with the editorial rules of the ISO/IEC Directives, Part 2 (see www.iso.org/directives).

Attention is drawn to the possibility that some of the elements of this document may be the subject of patent rights. ISO shall not be held responsible for identifying any or all such patent rights. Details of any patent rights identified during the development of the document will be in the Introduction and/or on the ISO list of patent declarations received (see www.iso.org/patents).

Any trade name used in this document is information given for the convenience of users and does not constitute an endorsement.

For an explanation of the voluntary nature of standards, the meaning of ISO specific terms and expressions related to conformity assessment, as well as information about ISO's adherence to the World Trade Organization (WTO) principles in the Technical Barriers to Trade (TBT), see www.iso.org/iso/foreword.html.

This document was prepared by Technical Committee ISO/TC 189, *Ceramic tile*, in collaboration with the European Committee for Standardization (CEN) Technical Committee CEN/TC 67, *Ceramic tiles*, in accordance with the Agreement on technical cooperation between ISO and CEN (Vienna Agreement).

This second edition cancels and replaces the first edition (ISO 10545-15:1995), which has been technically revised.

The main changes compared to the previous edition are as follows:

- addition of [Clause 3](#), subsequent clauses have been renumbered;
- modifications to [Clause 7](#);
- correction of typographical errors from the previous edition;
- application of this test method to all tile surfaces.

A list of all parts in the ISO 10545 series can be found on the ISO website.

Any feedback or questions on this document should be directed to the user's national standards body. A complete listing of these bodies can be found at www.iso.org/members.html.

Ceramic tiles —

Part 15:

Determination of lead and cadmium given off by tiles

1 Scope

This document specifies a method for the determination of lead and cadmium given off by the ceramic tiles surface.

2 Normative references

The following documents are referred to in the text in such a way that some or all of their content constitutes requirements of this document. For dated references, only the edition cited applies. For undated references, the latest edition of the referenced document (including any amendments) applies.

ISO 3696:1987, *Water for analytical laboratory use — Specification and test methods*

ISO 6353-2:1983, *Reagents for chemical analysis — Part 2: Specifications — First series*

3 Terms and definitions (standards.iteh.ai)

No terms and definitions are listed in this document.

ISO and IEC maintain terminological databases for use in standardization at the following addresses:

- ISO Online browsing platform: available at <https://www.iso.org/obp>
- IEC Electropedia: available at <http://www.electropedia.org/>

4 Principle

Exposure of the surface of a ceramic tile to an acetic acid solution. Determination of the amount of lead and cadmium released into the solution by an appropriate method.

5 Reagents

5.1 General

During the analysis, unless otherwise indicated, use only the reagents specified in ISO 6353-2 if indicated, if not, use reagents of recognized analytical grade, and grade 2 complying with ISO 3696:1987.

5.2 Test solution

Prepare acetic acid solution, 4 % (V/V) as follows: add 40 ml of glacial acetic acid (R 1 of ISO 6353-2:1983) to 960 ml of distilled water of grade 2.

6 Apparatus and materials

Atomic absorption spectrometer, or other suitable apparatus for the analysis of lead and cadmium from solution.

Other materials needed are as follows: silicone sealant in a tube or dispenser, enabling a ribbon of clear silicone (neutral cure) sealant approximately 6 mm in diameter to be formed; impervious cover, made of glass or ceramic or rigid plastic; neutral detergent for glassware; white cloth, made of cotton or flax; class A glass measuring cylinder (ISO 4788).

7 Test specimens

The number of tiles and specimens is reported in [Table 1](#).

Table 1 — Number of tiles and specimens

Tile area cm ² (nominal size)	Number of tiles	Number of speci- mens for each tile	Total number of specimens	Minimum area by specimens to be tested cm ²
tile area ≤ 400	3	1	3	100 ^a
400 < tile area ≤ 3600	3	1	3	100
tile area > 3600	1	3	3	100 ^b

^a In case of a tile with an area < 100 cm², a suitable number of tiles shall be assembled in order to reach 100 cm² without considering the joints. Joint shall be filled with a silicone sealant.

^b In case of a tile with an area > 3600 cm², specimens, being representative of the surface of the whole tile, shall be mandatorily cut from each tile.

The surface of a specimen to be tested shall be clean and free from grease or other materials that may interfere with the performance of the test. To ensure cleanliness, the specimen shall be thoroughly washed in tap water containing a small amount of neutral detergent, and rinsed with grade 2 water, then dried either by allowing to drain or with a soft clean cloth. After washing, care shall be taken to avoid handling the surface. Apply a ribbon of silicone sealant 6 mm wide, to the surface. Visually ensure that the ribbon has continuous contact with the surface without gaps. The ribbon shall be high enough to allow the required volume of the test solution to be added and the distance between the edge of the ribbon and the solution surface shall be no more than 1 mm. Allow the sealant to dry over-night. Measure and calculate the area *A*, in square decimetres, of the surface to be tested.

8 Procedure

Place each specimen on a flat horizontal surface in a room at a temperature of (20 ± 2) °C. Fill the space formed by the ribbon of silicone sealant with a volume, *V*, of the test solution, measured at the same temperature using the measuring cylinder. Place the cover on the specimen to minimize contamination and evaporation. A convenient way of doing this is illustrated in [Figure 1](#). Keep the temperature of the room at 20 ± 2 °C during the test and protect the test assembly from sunlight or other thermal sources. After 24 h ± 30 min, remove the cover, stir the acid thoroughly to ensure its homogeneity and remove an aliquot portion of the solution for analysis. Determine the amount of lead and cadmium extracted by an appropriate method: atomic absorption spectrometry is a possible method. Take into account any small amounts of lead and cadmium present in the reagents and water used, for example by a blank determination.

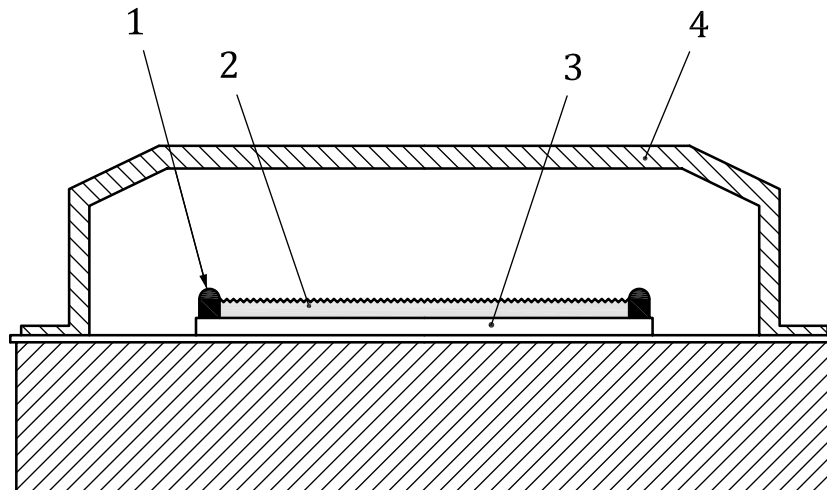
**Key**

- 1: silicone ribbon
- 2: test solution
- 3: tile
- 4: impervious cover

Figure 1 — Convenient method of covering tiles during testing

STANDARD PREVIEW
(standards.iteh.ai)

9 Expression of results

The mass of lead (Pb) and cadmium (Cd) extracted per unit of surface $\rho_A(M)$, expressed in milligrams per square decimetre, is calculated using the following formula:

$$\rho_A(M) = \rho(M) \frac{V}{1000 \cdot A} \quad (1)$$

where

M is the metal extracted (Pb or Cd);

$\rho(M)$ is the concentration, in milligrams per litre, of metal, M, in the extract;

V is the volume, in millilitres, of acetic acid added to the tile;

A is the area, in square decimetres, of surface tested.

10 Test report

The test report shall include the following information:

- a) reference to this document and relevant year of publication;
- b) a description of the tiles, including their nominal sizes;
- c) the specimens' preparation and the measured area for test;
- d) the mass concentration of lead in the extract, $\rho(\text{Pb})$, in milligrams per litre, and mass of lead extracted per unit of surface, $\rho_A(\text{Pb})$, in milligrams per square decimetre;
- e) the mass concentration of cadmium in the extract, $\rho(\text{Cd})$, in milligrams per litre, and mass of cadmium extracted per unit of surface, $\rho_A(\text{Cd})$, in milligrams per square decimetre.