Ophthalmic optics — Review of the test methods used to assess scratch and abrasion resistance of spectacle lenses

Optique ophtalmique — Revue des méthodes de test utilisées pour évaluer la résistance à la rayure et à l'abrasion des verres ophtalmiques

iTeh STANDARD PREVIEW
(standards.iteh.ai)

[ISO/TR 21958:2019](https://standards.iteh.ai/catalog/standards/sist/98cf9216-0159-41e8-af51-85cc16e11e88/iso-tr-21958-2019)

<https://standards.iteh.ai/catalog/standards/sist/98cf9216-0159-41e8-af51-85cc16e11e88/iso-tr-21958-2019>



iTeh STANDARD PREVIEW
(standards.iteh.ai)

ISO/TR 21958:2019

<https://standards.iteh.ai/catalog/standards/sist/98cf9216-0159-41e8-af51-85cc16e11e88/iso-tr-21958-2019>



COPYRIGHT PROTECTED DOCUMENT

© ISO 2019

All rights reserved. Unless otherwise specified, or required in the context of its implementation, no part of this publication may be reproduced or utilized otherwise in any form or by any means, electronic or mechanical, including photocopying, or posting on the internet or an intranet, without prior written permission. Permission can be requested from either ISO at the address below or ISO's member body in the country of the requester.

ISO copyright office
CP 401 • Ch. de Blandonnet 8
CH-1214 Vernier, Geneva
Phone: +41 22 749 01 11
Fax: +41 22 749 09 47
Email: copyright@iso.org
Website: www.iso.org

Published in Switzerland

Contents

	Page
Foreword	iv
1 Scope	1
2 Normative references	1
3 Terms and definitions	1
4 Background	1
5 Mechanisms of mechanical abrasion and scratching of lens surfaces	2
5.1 Discussion and scratch mechanisms.....	2
5.2 Testing and the different forms of damage.....	4
5.3 Assessing surface damage.....	5
6 Test method description	5
6.1 Steel wool test.....	5
6.1.1 Principle.....	5
6.1.2 Description.....	5
6.1.3 Pros and cons.....	7
6.2 Tumble test.....	7
6.2.1 Principle.....	7
6.2.2 Description.....	8
6.2.3 Pros and cons.....	9
6.3 Eraser test.....	9
6.3.1 Principle.....	9
6.3.2 Description.....	9
6.3.3 Pros and cons.....	11
6.4 Bayer test (Oscillating abrasive grain test).....	11
6.4.1 Principle.....	11
6.4.2 Description.....	12
6.4.3 Pros and cons.....	13
6.5 Nano scratch (Diamond point loading device).....	13
6.5.1 Principle.....	13
6.5.2 Description.....	14
6.5.3 Pros and cons.....	14
6.6 Taber abrasion wheel test.....	15
6.6.1 Principle.....	15
6.6.2 Description.....	15
6.6.3 Pros and cons.....	16
6.7 ISO 8980-5 “Minimum requirements for spectacle lens surfaces claimed to be abrasion-resistant”.....	16
6.7.1 Principle.....	16
6.7.2 Description.....	17
6.7.3 Pros and cons.....	17
7 Conclusion	18
Bibliography	19

Foreword

ISO (the International Organization for Standardization) is a worldwide federation of national standards bodies (ISO member bodies). The work of preparing International Standards is normally carried out through ISO technical committees. Each member body interested in a subject for which a technical committee has been established has the right to be represented on that committee. International organizations, governmental and non-governmental, in liaison with ISO, also take part in the work. ISO collaborates closely with the International Electrotechnical Commission (IEC) on all matters of electrotechnical standardization.

The procedures used to develop this document and those intended for its further maintenance are described in the ISO/IEC Directives, Part 1. In particular, the different approval criteria needed for the different types of ISO documents should be noted. This document was drafted in accordance with the editorial rules of the ISO/IEC Directives, Part 2 (see www.iso.org/directives).

Attention is drawn to the possibility that some of the elements of this document may be the subject of patent rights. ISO shall not be held responsible for identifying any or all such patent rights. Details of any patent rights identified during the development of the document will be in the Introduction and/or on the ISO list of patent declarations received (see www.iso.org/patents).

Any trade name used in this document is information given for the convenience of users and does not constitute an endorsement.

For an explanation of the voluntary nature of standards, the meaning of ISO specific terms and expressions related to conformity assessment, as well as information about ISO's adherence to the World Trade Organization (WTO) principles in the Technical Barriers to Trade (TBT), see www.iso.org/iso/foreword.html.

This document was prepared by Technical Committee ISO/TC 172, *Optics and photonics*, Subcommittee SC 7, *Ophthalmic optics and instruments*.

Any feedback or questions on this document should be directed to the user's national standards body. A complete listing of these bodies can be found at www.iso.org/members.html.

Ophthalmic optics — Review of the test methods used to assess scratch and abrasion resistance of spectacle lenses

1 Scope

This document describes the most commonly used test methods considered in standardization work relating to scratch and abrasion resistance of plastic spectacle lenses along with their technical capacities and limitations. It includes the ISO test method for assessment of claims for basic abrasion resistance in ISO 8980-5.

This document is intended to be of benefit to any future interest in ISO standardization on scratch and abrasion resistance of spectacle lenses.

2 Normative references

There are no normative references in this document.

3 Terms and definitions

No terms and definitions are listed in this document.

ISO and IEC maintain terminological databases for use in standardization at the following addresses:

- ISO Online browsing platform: available at <https://www.iso.org/obp>
- IEC Electropedia: available at <http://www.electropedia.org/>

4 Background

As the spectacle lens market shifted from glass toward plastic in the 1970s, the demand for improved abrasion resistant coatings for plastic lenses resulted in the need to assess and compare the performance of the new coatings in the market.

A number of very different abrasion test methods were developed over the years which employ a variety of ways to abrade the lens. Each method uses a unique scratch or abrasion mechanism which affects how the lens is assessed for its ability to resist damage.

In addition, different methods of assessment of test lens surface damage are used by these test methods.

Together, the different mechanisms of abrading and the different assessment methods often result in dramatically different ranking and rating of the performances of lens surfaces that do not reflect marketplace performance and the experience of wearers in real life conditions.

Considerable national and ISO standardization activity was directed to find one single test method that would reliably predict wearer experience or market performance. After much work, it was realized this goal could not be achieved and that work was abandoned.

In its place an ISO standard (ISO 8980-5) was successfully developed with a methodology capable of determining whether a lens surface claimed to be abrasion resistant could achieve a basic performance level. This test method follows the only known approach avoiding the possibility of using the standard test to rank products in the market.

Further work followed the successful publishing of ISO 8980-5, this time with the aim of creating a standard for “enhanced abrasion resistance” at a higher level than “basic level”.

However, after some years of work, the project group responsible was unable to achieve the objective of a single test able to predict market performance and real wear experience, so further work was abandoned.

This document describes in detail the most common abrasion test methods used for assessing spectacle lens surfaces developed over several decades and which were considered during standardization work, along with their technical capabilities and limitations. It includes the ISO test method for assessment of claims of basic abrasion resistance in ISO 8980-5.

This document also explains the different mechanisms of abrasion and scratching.

5 Mechanisms of mechanical abrasion and scratching of lens surfaces

5.1 Discussion and scratch mechanisms

When attempting to classify and quantify damage to a lens surface, the spectacle industry itself has differences in opinions on the definitions, descriptions and classifications of damage types. A standardized method for assessing and quantifying such damage is therefore an extremely complex activity that will always have different views on interpretation of test results.

Two typical terms used in the spectacle lens industry to describe lens surface damage are 'abrasion' and 'scratching'.

No single agreed definitions exist for these terms in the industry, however basic descriptions could be:

- SCRATCHING – A process of degrading from a pristine surface of a lens caused by initial contact / impact of an object on a lens surface and then friction / motion of the object across the lens surface.

synonyms: score, abrade, scrape, roughen, scuff (up), lacerate, groove, gash, engrave, incise, gouge

- ABRASION – A process of degrading from a pristine surface of a lens caused by the pitting or wearing away of the surface.

synonyms: wearing away/down, wearing, erosion, scraping, corrosion, being eaten away, chafing, rubbing, stripping, flaying, excoriation

An example of *abrasion* might be when one continually rubs a lens surface with a cloth or tissue, and with time a degradation of the surface /coating occurs that alters its appearance and function. *Scratching* might occur if sand or debris were on the cloth and the drag of this particle caused specific localized damage as it was dragged across the surface. The latter is likely to be noticed more readily by the wearer when holding up the lens up to the light as it is less uniform in nature.

One view is that 'Abrasion' is an umbrella term for description of many types of damage to a lens surface and that 'scratching' is just one of the subsets of damage types.

Another view is that Abrasion is typically the umbrella term to describe 'impact' related damage and Scratching is typically the umbrella term used for describing friction related damage.

Scratching is the term often used to describe visible damage to a lens surface that occurs in straight lines.

Scratching is often considered to be a single occurrence of damage with a single contact point from an object and with sustained contact, motion in a continuous direction.

Abrasion is often considered to be the damage caused by repeat occurrences of multiple contact points of an object over a larger surface area.

Both scratching and abrasion mechanisms of damage are dependent on the interaction of factors such as force/pressure, contact area, relative material hardness, duration of contact and repeated exposure to the damage, friction coefficients of the surfaces, surface roughness etc. on the lens. (The 'lens' includes the coating and substrate combination).

Abrasion resistance and scratch resistance are terms that have been typically used in an interchangeable way in the industry. The relevant ISO 8980-5 standard is titled 'Minimum requirements for spectacle lens surfaces claimed to be abrasion-resistant' and uses the term 'abrasion resistance' whereas marketing sectors of the industry usually use the term scratch resistance.

Damage types can be grouped as shown in the [Table 1](#) below.

Table 1 — Damage types

friction related	impact related
tearing	pitting
cutting	chipping
scuffing	clash

Damage to a lens surface can be a single type or a combination of the types shown in the table above. It can be linear in direction or randomized dependent on the testing mechanism.

'Scratching' may be considered as a combination of both Impact and Friction damage types as a scratch can originate from an object's contact / impact with the surface, and then translate to a friction related mechanism of damage (tearing or cutting), as the object maintains contact and is moved across the surface.

In real life performance, a lens claimed to have significant scratch resistance properties, might actually tolerate one type of damage mechanism well, but perform poorly against a different damage mechanism.

Case study example:

(standards.iteh.ai)

Abrasion damage can be caused by daily wiping off dust and fingerprints from the lenses. The force of our fingertips is roughly 10 N on an area of about 1 cm². Several wipes with a clean soft cloth do not cause any damage to a clean lens surface. Only after several 1000 wipes the contact angle of hydrophobic topcoats starts to decrease, but usually the coated surface of a lens does not show any visible damage or a change of reflection colour. In real life neither the cloth nor the lens surface always is perfectly clean: there are small grains of any kind of dust or even sand. When wiping over the lens surface they cause the well-known multitude of lighter and stronger scratches, which can be detected on lenses worn for several months. This can be understood by estimating the pressure of a sand grain onto the lens surface. On the cloth side of the grain the soft cloth adapts to the shape of the grain. On the lens side the sand grain and the lens surface can elastically adapt their shapes only a little bit which means that the contact area is much smaller than the diameter of the grain. Assuming that the grain has a diameter of 0,1 mm = 100 µm the contact area roughly is smaller than about (10 µm)². Because the force is the same as at the cloth side the pressure to the contact area on the lens is 2 magnitudes higher which causes plastic deformation i.e. scratches. Using a microscope typical scratches have a width of 1 µm to 10 µm and a depth of up to 1 µm often accompanied by coating cracks and even delamination.

In addition to cleaning of the lenses there are further typical causes for damaging lens surfaces:

- Storage behaviour, i.e. face down on a car dashboard where there is a level of constant vibration;
- Being placed face down on a hard bench / desk surface;
- Being carried around in a handbag, contacting other articles;
- Being placed in a shirt pocket, constantly rubbing against the pocket material;
- Falling off into the dirt or floor, etc.

5.2 Testing and the different forms of damage

There is a range of current tests for assessing product ‘resilience’ to damage by scratching and/or abrasion mechanisms but, however, no single test has been shown to align with real life experience and the tests typically will create and measure a specific form of damage and interaction between surfaces.

Some input test parameters to the tests as mentioned earlier are: force/pressure, contact area, relative material hardness, duration of contact and repeated exposure to the damage, abrasive media, load, velocity and number of cycles and any combination of these can result in different results of the test, as different mechanism of surface damage occur.

Due to the different mechanical actions employed in the various tests, different directional damage components / forces are involved. Some have consistently linear motions giving linear damage patterns and others have more randomized directions of damage, as shown in [Figure 1](#) below.

Micro-hardness, elastic modulus, roughness and friction play a different role in each type of wear test with its intrinsic predominant dynamic phenomena. Static hardness tests for example do not take into account these dynamic phenomena.

Historically steel wool and taber tests results have shown a dependency on micro hardness and elasticity, while the tumble test shows a dependency on surface roughness. Surface friction however, correlates well to all three abrasion tests.

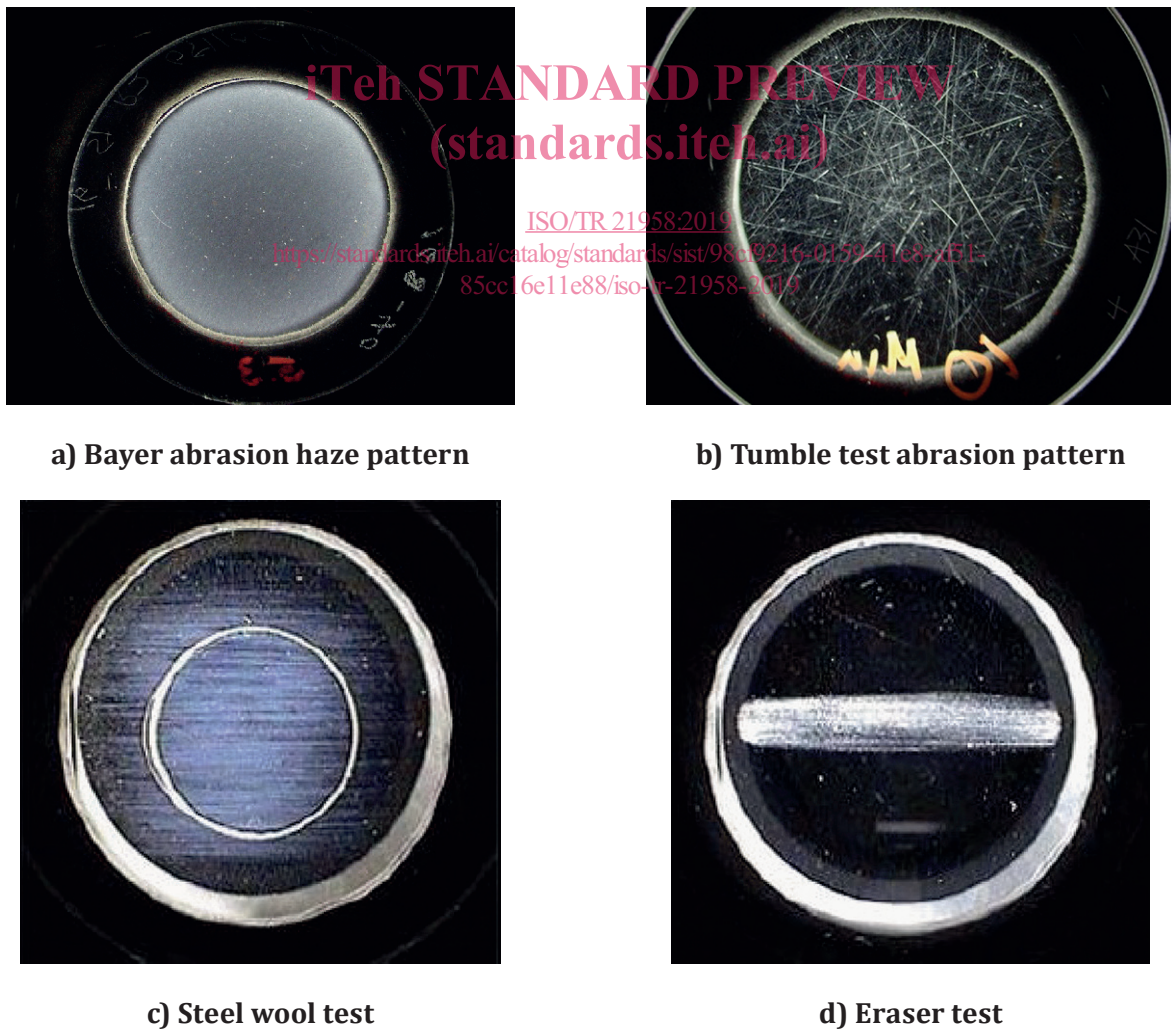

Figure 1 — Damage examples

[Figure 1](#) a) shows many fine scratches and a hazy underlying background. Semi-randomized direction to damage pattern – some linear component.

[Figure 1](#) b) shows coarse heavy scratches but a clearer underlying background. Randomized directional damage.

[Figure 1](#) c) shows linear damage pattern from steel wool test.

[Figure 1](#) d) shows linear damage pattern.

5.3 Assessing surface damage

The most common methods to assess damage are by measuring changes in luminous transmittance, light scatter, and subjective evaluation of cosmetic appearance before and after damage has been applied.

One problem with this approach is that results can appear to conflict with other methods of assessment. For example, a single heavy scratch that is unacceptable cosmetically might give a satisfactory result in a test based on a scattered light measurement methodology.

Abrasion tests that provide uniform damage (such as the Bayer test) are well suited for assessment using scattered light (haze) measurement techniques. A test like the Tumble test might show more realistic scratch patterns, but is not as well suited to assessment with haze techniques.

A slightly pitted surface might be acceptable in cosmetic terms but give a poor result when tested using a scattered light measurement. Therefore, each test has to be combined with the best fitting kind of damage measurement to get a useful evaluation. Well-proven combinations are for example Bayer test with haze measurement and eraser test with visual examination against a light-dark-boundary as defined in ISO 8980-5.

It may be necessary to get a better detailed understanding of abrasion / scratch resistance of coated lenses. Usually the surface is examined with the aid of microscopes, electron microscopes or even more expensive surface analysis tools.

6 Test method description

6.1 Steel wool test

6.1.1 Principle

The focus of the test is on the amount of force required to reach the threshold of penetration of the surface before scratching occurs. This test was created specifically to test abrasion resistance coating for the spectacle lens market. It's a friction related type of damage: scratches with linear pattern. Other versions of this test are performed with different grades of steel wool and with different number of cycles and weight and velocity.

6.1.2 Description

6.1.2.1 Surface damage procedure summary

The procedure, for evaluating the abrasion resistance, requires a controlled movement with a specified number of cycles under specified load conditions of a specified steel wool pad, as abrasive medium, over the surface of plastic lenses (see [Figure 2](#)).

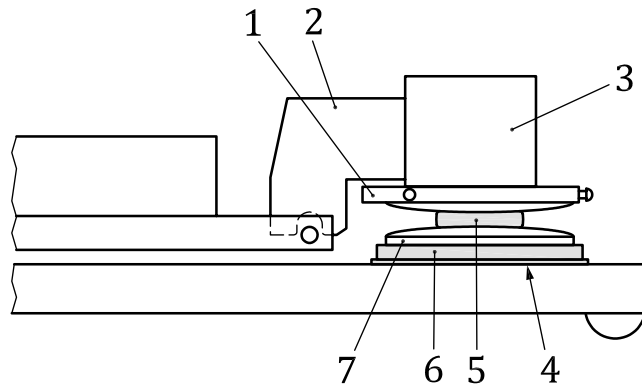

Key

- 1 pad holder
- 2 block holder
- 3 1,8 ± 0,2 kg weight
- 4 metal plate
- 5 steel wool pad
- 6 rubber pad
- 7 test lens

Figure 2 — Steel wool test diagram

ISO/TR 21958:2019
<https://standards.iteh.ai/catalog/standards/sist/98c9216-0159-41e8-af51-85cc16e11e88/iso-tr-21958-2019>
 iTeh STANDARD PREVIEW

Each steel wool pad, as shown in Figure 3, is qualified following a detailed procedure and it is fundamental to this test that control lenses of consistent manufacture are used.

One test run consists of a total of 9 lenses (6 samples plus 3 control lenses) abraded using a single steel wool pad properly conditioned.

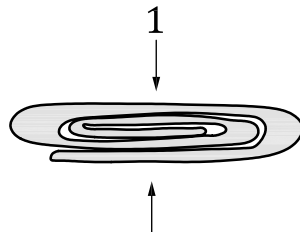

Key

- 1 press flat

Figure 3 — Folded steel wool

6.1.2.2 Method of assessment of surface damage

The parameter of interest is the average measured increase in damage (as estimated by increase in haze detected by a suitable instrument) after 75 cycles.

Superior statistics can be achieved and confidence in the results enhanced if more data points are available, on which a linear least squares regression can be performed.

Differences can be observed visually when they are significant but the evaluation method for the steel wool test uses haze measurements before and after each sequence (Hazemeter).

The abrasion ratios of test lenses are calculated relative to all control lenses.

Figure 4 shows an example of steel wool damage.

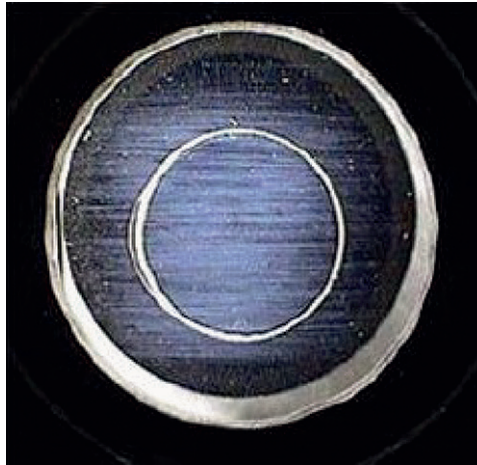

Figure 4 — Image of steel wool damage pattern

6.1.3 Pros and cons

6.1.3.1 Pros

- If the most prevalent mode of failure is scratching, the use of steel wool is well suited to quickly generate scratches on the surface of a material in linear motion.
- Evaluate different optically clear materials; same coating (same film thickness) on different substrates.

6.1.3.2 Cons

- There is no worldwide standard for grading steel wool.
- The preparation of the steel wool pad by folding and with proper fibre orientation is critical for measurement. Conditioning of the pads is necessary for improved consistency.
- Haze assessment is not the most suitable method for a linear pattern of damage.
- Different abrasive media load, velocity and number of cycles can result in different results of the test, as different mechanism of surface damage occurs.
- This test method has not been shown to correlate with real-life abrasion resistance of lens surfaces.

6.2 Tumble test

6.2.1 Principle

The “Tumble test” was developed at a time when tintable hard coatings on plastic lenses were first being introduced into the marketplace. At the time, there was a significant variability in real life performance of coatings claiming to be abrasion resistant. During the tumble test, the lens is placed inside a drum that is rotated. A mixture of abrasive media (scrub pads, foam, wheat, sawdust, silica sand, and emery) is free to move inside the barrel, invoking wear on the lens during the test. The amount of damage to the test lens is compared to the amount of damage on a reference lens that was inside the drum at the same time.