**Fine ceramics (advanced ceramics,
advanced technical ceramics) —
Mechanical properties of ceramic
composites at ambient temperature
in air atmospheric pressure —
Determination of hoop tensile
properties of tubes**

Céramiques techniques (céramiques avancées, céramiques techniques avancées) — Propriétés mécaniques des céramiques composites à température ambiante et à pression atmosphérique — Détermination des propriétés en traction circonférentielle de tubes

ISO 21971:2019

<https://standards.iteh.ai/catalog/standards/iso/7dbc081e-8327-49db-97d0-76795bc725c3/iso-21971-2019>



iTeh Standards
(<https://standards.iteh.ai>)
Document Preview

[ISO 21971:2019](https://standards.iteh.ai/catalog/standards/iso/7dbc081e-8327-49db-97d0-76795bc725c3/iso-21971-2019)

<https://standards.iteh.ai/catalog/standards/iso/7dbc081e-8327-49db-97d0-76795bc725c3/iso-21971-2019>



COPYRIGHT PROTECTED DOCUMENT

© ISO 2019

All rights reserved. Unless otherwise specified, or required in the context of its implementation, no part of this publication may be reproduced or utilized otherwise in any form or by any means, electronic or mechanical, including photocopying, or posting on the internet or an intranet, without prior written permission. Permission can be requested from either ISO at the address below or ISO's member body in the country of the requester.

ISO copyright office
CP 401 • Ch. de Blandonnet 8
CH-1214 Vernier, Geneva
Phone: +41 22 749 01 11
Fax: +41 22 749 09 47
Email: copyright@iso.org
Website: www.iso.org

Published in Switzerland

Contents

| | Page |
|---|-----------|
| Foreword | v |
| 1 Scope | 1 |
| 2 Normative references | 1 |
| 3 Terms and definitions | 1 |
| 4 Principle | 3 |
| 5 Apparatus | 4 |
| 5.1 Pressurizing system..... | 4 |
| 5.2 Test specimen gripping and end closure..... | 4 |
| 5.3 Strain measurement..... | 5 |
| 5.3.1 General..... | 5 |
| 5.3.2 Strain gauges..... | 5 |
| 5.3.3 Digital image correlation..... | 5 |
| 5.4 Pressure and data recording systems..... | 6 |
| 5.5 Measurement of dimensions..... | 6 |
| 6 Tubular test specimen | 7 |
| 6.1 Specimen specifications..... | 7 |
| 6.1.1 General..... | 7 |
| 6.1.2 Dimension..... | 7 |
| 6.1.3 Geometry..... | 7 |
| 6.1.4 Tolerances and variability..... | 8 |
| 6.2 Specimen preparation..... | 8 |
| 6.2.1 General..... | 8 |
| 6.2.2 As-fabricated..... | 8 |
| 6.2.3 Application-matched machining..... | 9 |
| 6.2.4 Customary practices..... | 9 |
| 6.2.5 Standard procedure..... | 9 |
| 6.3 Test count and test specimens sampling..... | 9 |
| 7 Test procedure | 9 |
| 7.1 General..... | 9 |
| 7.2 Test mode and rates..... | 9 |
| 7.3 Testing technique..... | 10 |
| 7.3.1 Measurement of test specimen dimensions..... | 10 |
| 7.3.2 Instrumentation of test specimen..... | 10 |
| 7.3.3 Setting-up of strain measurement means..... | 10 |
| 7.3.4 Measurements..... | 11 |
| 7.3.5 Post-test analyses..... | 12 |
| 7.4 Test validity..... | 12 |
| 8 Calculation of results | 12 |
| 8.1 Test specimen origin..... | 12 |
| 8.2 Hoop tensile stress and strain..... | 12 |
| 8.3 Hoop tensile strength and corresponding strain..... | 13 |
| 8.4 Proportionality ratio or pseudo-elastic modulus in circumferential direction..... | 14 |
| 8.4.1 Stress-strain curves with a linear region..... | 14 |
| 8.4.2 Nonlinear stress-strain curves..... | 14 |
| 8.5 Poisson's ratio (optional)..... | 15 |
| 8.6 Statistics..... | 15 |
| 9 Test report | 15 |
| 9.1 General..... | 15 |
| 9.2 Testing information..... | 15 |
| 9.3 Test specimen and material..... | 16 |
| 9.3.1 Tubular test specimen drawing or reference..... | 16 |

ISO 21971:2019(E)

| | | |
|---------------------|--|-----------|
| 9.3.2 | Description of the test material | 16 |
| 9.4 | Equipment and test parameters | 16 |
| 9.5 | Test results..... | 16 |
| Bibliography | | 18 |

iTeh Standards (<https://standards.iteh.ai>) Document Preview

[ISO 21971:2019](https://standards.iteh.ai/catalog/standards/iso/7dbc081e-8327-49db-97d0-76795bc725c3/iso-21971-2019)

<https://standards.iteh.ai/catalog/standards/iso/7dbc081e-8327-49db-97d0-76795bc725c3/iso-21971-2019>

Foreword

ISO (the International Organization for Standardization) is a worldwide federation of national standards bodies (ISO member bodies). The work of preparing International Standards is normally carried out through ISO technical committees. Each member body interested in a subject for which a technical committee has been established has the right to be represented on that committee. International organizations, governmental and non-governmental, in liaison with ISO, also take part in the work. ISO collaborates closely with the International Electrotechnical Commission (IEC) on all matters of electrotechnical standardization.

The procedures used to develop this document and those intended for its further maintenance are described in the ISO/IEC Directives, Part 1. In particular, the different approval criteria needed for the different types of ISO documents should be noted. This document was drafted in accordance with the editorial rules of the ISO/IEC Directives, Part 2 (see www.iso.org/directives).

Attention is drawn to the possibility that some of the elements of this document may be the subject of patent rights. ISO shall not be held responsible for identifying any or all such patent rights. Details of any patent rights identified during the development of the document will be in the Introduction and/or on the ISO list of patent declarations received (see www.iso.org/patents).

Any trade name used in this document is information given for the convenience of users and does not constitute an endorsement.

For an explanation of the voluntary nature of standards, the meaning of ISO specific terms and expressions related to conformity assessment, as well as information about ISO's adherence to the World Trade Organization (WTO) principles in the Technical Barriers to Trade (TBT) see www.iso.org/iso/foreword.html.

This document was prepared by Technical Committee ISO/TC 206, *Fine ceramics*.

Any feedback or questions on this document should be directed to the user's national standards body. A complete listing of these bodies can be found at www.iso.org/members.html.

<https://standards.iteh.ai>
ISO 21971:2019

<https://standards.iteh.ai/catalog/standards/iso/7dbc081e-8327-49db-97d0-76795bc725c3/iso-21971-2019>

Fine ceramics (advanced ceramics, advanced technical ceramics) — Mechanical properties of ceramic composites at ambient temperature in air atmospheric pressure — Determination of hoop tensile properties of tubes

1 Scope

This document specifies the conditions for the determination of hoop tensile properties of ceramic matrix composite (CMC) tubes with continuous fibre-reinforcement at ambient temperature in air atmospheric pressure. This document is specific to the tubular geometries since fibre architecture and specimen geometry factors in composite tubes are distinctly different from those in flat specimens.

This document provides information on the hoop tensile properties and stress-strain response, such as hoop tensile strength, hoop tensile strain at failure and elastic constants. The information can be used for material development, control of manufacturing (quality insurance), material comparison, characterization, reliability and design data generation for tubular components.

This document addresses, but is not restricted to, various suggested test piece fabrication methods. It applies primarily to ceramic and/or glass matrix composite tubes with a continuous fibrous-reinforcement: unidirectional (1D filament winding and tape lay-up), bi-directional (2D braid and weave) and tri-directional (x D, with $2 < x < 3$), subjected to an internal pressure.

Values expressed in this document are in accordance with the International System of Units (SI).

2 Normative references

The following documents are referred to in the text in such a way that some or all of their content constitutes requirements of this document. For dated references, only the edition cited applies. For undated references, the latest edition of the referenced document (including any amendments) applies.

ISO 3611, *Geometrical product specifications (GPS) — Dimensional measuring equipment: Micrometers for external measurements — Design and metrological characteristics*

ISO 20507, *Fine ceramics (advanced ceramics, advanced technical ceramics) — Vocabulary*

ASTM E2208-02, *Standard Guide for Evaluating Non-Contacting Optical Strain Measurement Systems*

3 Terms and definitions

For the purpose of this document, the terms and definitions given in ISO 20507 and the following apply.

ISO and IEC maintain terminological databases for use in standardization at the following addresses:

— ISO Online browsing platform: available at <https://www.iso.org/obp>

— IEC Electropedia: available at <http://www.electropedia.org/>

3.1

calibrated length

l

part of the test specimen that has uniform and minimum *external diameter* (3.3)

**3.2
gauge length**

L_0
initial distance between reference points on the test specimen in the *calibrated length* (3.1)

**3.3
external diameter**

d_o
outer distance through the centre of the tube from one side to the other in the *gauge length* (3.2)

**3.4
internal diameter**

d_i
inner distance through the centre of the tube from one side to the other in the *gauge length* (3.2)

**3.5
wall thickness**

h
distance between the *internal* (3.4) and *external diameters* (3.3) in the *gauge length* (3.2)

**3.6
hoop tensile strain**

$\epsilon_{\theta\theta}$
relative change in circumferential direction in the *gauge length* (3.2)

**3.7
axial strain**

ϵ_{zz}
relative change in the axial (or longitudinal) direction in the *gauge length* (3.2)

**3.8
hoop tensile stress**

$\sigma_{\theta\theta}$
stress supported by the test specimen in circumferential direction at any time in the test

**3.9
burst pressure**

P_F
highest recorded internal pressure undergone by the test specimen when tested to failure

**3.10
hoop tensile strength**

$\sigma_{\theta\theta,m}$
hoop tensile stress (3.8) calculated at the *burst pressure* (3.9)

**3.11
proportionality ratio or pseudo-elastic modulus in the circumferential direction**

$EP_{\theta\theta}$
slope of the initial linear section of the stress-strain curve

Note 1 to entry: Examination of the stress-strain curves for ceramic matrix composites allows definition in the following cases:

- a) Material with an initial linear domain in the stress-strain curve.

The proportionality ratio or pseudo-elastic modulus is termed the elastic modulus in the circumferential direction, $E_{\theta\theta}$, in the single case where the linearity starts near the origin.

- b) Material with no-linear section in the stress-strain curve.

In this case only stress-strain couples can be fixed.

3.12 Poisson's ratio

$\nu_{\theta z}$
negative ratio of circumferential to *axial strain* (3.7)

3.13 coordinate system

system used to determine location in space

Note 1 to entry: Cylindrical coordinates are adopted in this document.

Note 2 to entry: The notations shown in [Figure 1](#) apply for space representation.

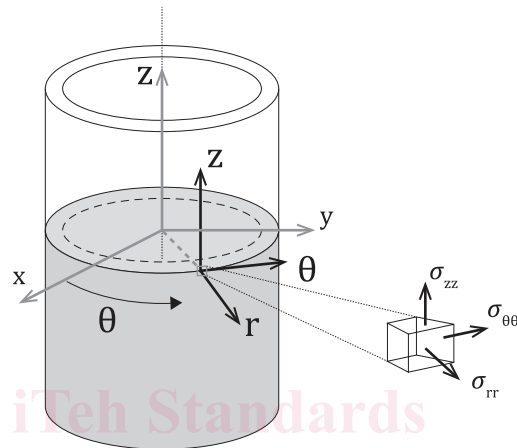

Key

z axial
r radial
 θ circumferential

Figure 1 — Cylindrical coordinate system used for the CMC tubes

4 Principle

A prepared tubular test specimen of specified dimensions is inserted into an appropriate test fixture assembly and subjected to monotonic loading via indirect internal pressure up to fracture. Uniform radial pressure is produced using hydraulic oil injection with a piston through an elastomeric bladder located inside the tubular test specimen. The elastomeric bladder mates to the inner diameter of the tubular test specimen, thus causing its expansion under pressure. The test is performed at constant piston displacement or constant strain (or constant loading rate). Both the applied pressure and resulting hoop tensile strain are measured and recorded simultaneously. The hoop tensile strength and corresponding strain are determined from the burst pressure while the various other hoop tensile properties are determined from the stress-strain response data.

Generally, the test is carried out under conditions of ambient temperature and environment.

NOTE 1 The resulting force from internal pressure loading is applied in the radial direction. Monotonic refers to a continuous non-stop test rate with no reversals from test initiation to final fracture.

NOTE 2 The method described in this document does not cover the possibility of applying pressurization via a dense rubber material in compressive without fluid.

5 Apparatus

5.1 Pressurizing system

The pressurizing system shall be able to apply a continuously increasing and uniform internal pressure to the tubular test specimen.

The following equipment is recommended for this test:

- a) an oil (or other fluid) bath maintained at uniform temperature;
- b) an annular and leak-tight elastomeric bladder surrounding the inner periphery of the tubular test specimen able to transmit a uniform pressure loading by its elasticity expansion;
- c) a test machine (or a press) capable of applying a determined compressive force on a piston free to move vertically to increase oil pressure in the elastomeric bladder.

Figure 2 shows a schematic example to illustrate the principle of a satisfactory pressurizing system.

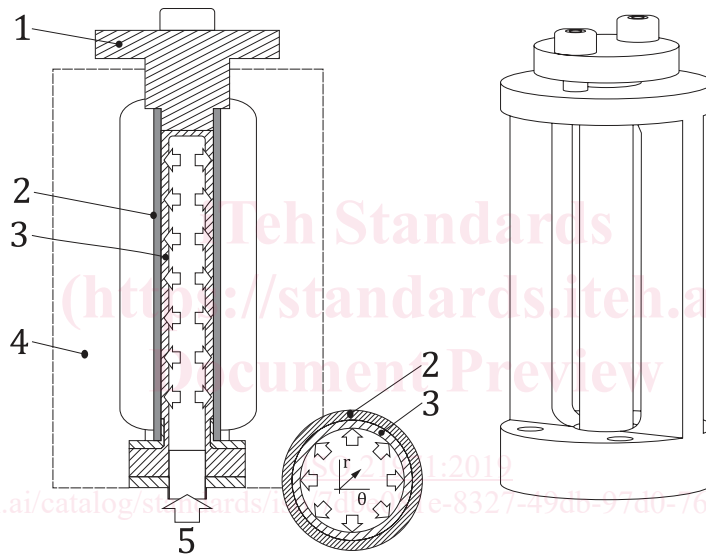

Key

- 1 cover plate
- 2 tubular test specimen
- 3 elastomeric bladder
- 4 space flange
- 5 oil inlet for pressurization (P)

Figure 2 — Example of hydrostatic pressurizing system for CMC tubular test specimen

5.2 Test specimen gripping and end closure

The gripping device shall be able to maintain the tubular test specimen in position to withstand internal pressure induced by the expansion of the elastomeric bladder while allowing it to move radially. An example of construction detail is shown in Figure 2 for which the tubular test specimen is mounted on a spacer flange. A cover plate is clamped on the flange with two screws to obtain a correct alignment.

The brittle nature of the CMCs requires particular attention to minimize crack initiation and fracture. Therefore, it is recommended that the attachment screws are released and then the adjustment screw adjusted to push the mating flanges back slightly until they come into contact with the tube, but without applying any axial force to it.