



Designation: ~~B49-08a~~ Designation: B49 – 09

Standard Specification for Copper Rod Drawing Stock for Electrical Purposes¹

This standard is issued under the fixed designation B49; the number immediately following the designation indicates the year of original adoption or, in the case of revision, the year of last revision. A number in parentheses indicates the year of last reapproval. A superscript epsilon (ϵ) indicates an editorial change since the last revision or reapproval.

This standard has been approved for use by agencies of the Department of Defense.

1. Scope*

1.1 This specification covers the requirements for rod drawing stock in diameters from $\frac{1}{4}$ to $1\frac{3}{8}$ in. (6.4 to 35 mm) produced from electrolytic tough-pitch or oxygen-free coppers and are suitable for further fabrication into electrical conductors.

1.2 The values stated in inch-pound units are to be regarded as standard. The values given in parentheses are mathematical conversions to SI units that are provided for information only and are not considered standard.

1.3 The following safety hazards caveat pertains only to Section 13. *This standard does not purport to address all of the safety concerns, if any, associated with its use. It is the responsibility of the user of this standard to establish appropriate safety and health practices and determine the applicability of regulatory limitations prior to use.*

2. Referenced Documents

2.1 The following documents in the current issue of the Book of Standards form a part of this specification to the extent referenced herein and define materials suitable for use in rod manufacture:

2.2 ASTM Standards:²

B5 Specification for High Conductivity Tough-Pitch Copper Refinery Shapes

B115 Specification for Electrolytic Copper Cathode

B170 Specification for Oxygen-Free Electrolytic Copper Refinery Shapes

B193 Test Method for Resistivity of Electrical Conductor Materials

B224 Classification of Coppers

B577 Test Methods for Detection of Cuprous Oxide (Hydrogen Embrittlement Susceptibility) in Copper

B846 Terminology for Copper and Copper Alloys

E8 Test Methods for Tension Testing of Metallic Materials

E18 Test Methods for Rockwell Hardness of Metallic Materials

E29 Practice for Using Significant Digits in Test Data to Determine Conformance with Specifications

E53 Test Method for Determination of Copper in Unalloyed Copper by Gravimetry

E478 ~~Test Methods for Chemical Analysis of Copper Alloys~~ Test Methods for Chemical Analysis of Copper Alloys

E1606 Practice for Electromagnetic (Eddy-Current) Examination of Copper Redraw Rod for Electrical Purposes

E2575 Test Method for Determination of Oxygen in Copper and Copper Alloys

2.3 Other Document:

NBS Handbook 100 *Copper Wire Tables*³

3. Terminology

3.1 For definitions of general terms relating to copper and copper alloys refer to Terminology B846.

4. Ordering Information

4.1 Orders for rod under this specification shall include the following information:

4.1.1 ASTM designation and year of issue,

4.1.2 Quantity of each size,

4.1.3 Type and requirements of copper (Sections 5-10),

¹ This specification is under the jurisdiction of ASTM Committee B05 on Copper and Copper Alloys and is the direct responsibility of Subcommittee B05.07 on Refined Copper.

Current edition approved Nov. 1, 2008-2009. Published December 2008-2009. Originally approved in 1923. Last previous edition approved in 2008 as B49 – 08a. DOI: 10.1520/B0049-08A-10.1520/B0049-09.

² For referenced ASTM standards, visit the ASTM website, www.astm.org, or contact ASTM Customer Service at service@astm.org. For *Annual Book of ASTM Standards* volume information, refer to the standard's Document Summary page on the ASTM website.

³ Available from National Technical Information Service (NTIS), 5285 Port Royal Rd., Springfield, VA 22161, http://www.ntis.gov.

*A Summary of Changes section appears at the end of this standard.

- 4.1.4 Finish (Sections 9 and 10),
- 4.1.5 Package with or without joints (see 5.3),
- 4.1.6 Rod diameter (see 9.2),
- 4.1.7 Inspection (Section 15),
- 4.1.8 Package size (see 19.1), and
- 4.1.9 Special package marking as agreed upon between the manufacturer and the purchaser (Section 19).
- 4.2 The following requirements are optional and should be specified in the contract or purchase order when required.
 - 4.2.1 Certification (Section 17) and
 - 4.2.2 Test Report (Section 18).

5. Material and Manufacture

5.1 The rod shall be fabricated from copper of such quality and purity that the finished product shall have the properties and characteristics prescribed in this specification.

NOTE 1—The following specifications define materials suitable for use: Specification B5, or Specification B115, or Specification B170.

5.2 Copper of special qualities, forms, or types, as agreed upon between the manufacturer and the purchaser and that will conform to the requirements prescribed in this specification may also be used.

5.3 The rod coils shall be furnished in continuous lengths with or without joints, as ordered.

TABLE 1 Chemical Composition^A

UNS Number Copper Type	C11040 ETP	C10100 OFE ^B	C10200 OF ^C	C11000 ETP
Copper, min	99.90 % ^D	99.99 % ^D	99.95 % ^E	99.90 % ^E
			incl silver	incl silver
	ppm	ppm	ppm	ppm
Tellurium, max	2	2
Selenium, max	2	3
Bismuth, max	1.0	1.0
Group total, max	3
Antimony, max	4	4
Arsenic, max	5	5
Tin, max	5	2
Lead, max	5	5
Iron, max	10	10
Nickel, max	10	10
Sulfur, max	15	15
Silver, max	25	25
Oxygen	100–650	5 max	10 max	...
Maximum allowable	65 ^F
total				
Cadmium, max	...	1
Phosphorus, max	...	3
Zinc, max	...	1
Manganese, max	...	0.5

^A See 13.1.2.

^B From B170 Grade 1 copper or equivalent.

^C From B170 Grade 2 copper or equivalent.

^D By difference. See 13.1.2 and 13.1.3.

^E See 13.1.1.

^F Not including oxygen.

6. Chemical Composition

6.1 Each rod type shall conform to the chemical composition requirements prescribed in Table 1 for the type of copper ordered (Section 4).

6.2 By agreement between the manufacturer and the purchaser, the addition of silver up to an average of 30 troy oz per short ton of copper (0.10 %) will be considered within the specification, copper including silver in the chemical analysis, with no individual silver analysis to exceed 35 troy oz per short ton (0.12 %). In the case of oxygen-free silver-bearing coppers, the designation OFS (oxygen-free, silver-bearing) will be used as shown in Classification B224 and will include the UNS Nos. C10400, C10500, and C10700 as defined by the agreed silver content.

6.3 Silver-bearing tough-pitch copper corresponds to the designation STP (silver-bearing tough-pitch) as shown in Classification B224 and to coppers having UNS Nos. C11300, C11400, C11500, and C11600.

6.4 *Oxygen Content*—Oxygen-free copper as described herein is defined as a copper containing not in excess of 0.0010 % (10 ppm) oxygen and produced without the use of metallic or other deoxidizers.

7. Physical Property Requirements

7.1 *Electrical Resistivity*—Resistivity of the copper in the annealed condition (See Note X1.1) shall not exceed the following values at 20°C:

Type of Copper	Resistivity, max, at 20°C Annealed, $\Omega \cdot \text{g}/\text{m}^2$
UNS C10100 only	0.15176 (101.00 % IACS min)
All others	0.15328 (100.00 % IACS min)

8. Mechanical Property Requirements

8.1 *Tensile Tests*—Rod finished by hot working or annealing shall have a minimum elongation of 30 % in 10 in. (250 mm). (Note X1.2 and Test Methods E8.)

8.2 *Torsion Tests*—~~If torsion tests are requested, refer to Torsion (Twist) Tests~~—Torsion tests are not a requirement of this specification. However, a discussion will be found in Note X1.3.

8.3 *Embrittlement (Bend) Test:*

8.3.1 A test to reflect propensity towards hydrogen embrittlement shall be performed only on oxygen-free copper.

8.3.2 The specimen shall be tested in accordance with 13.6 and Specification B170.

8.3.3 The specimen, prepared and tested from the OFE (oxygen-free electronic) copper (UNS C10100) listed in Table 1, shall withstand without breaking into two pieces, a minimum of ten (10) reverse bends.

8.3.4 The specimen, prepared and tested from the OF (oxygen-free) copper (UNS C10200) listed in Table 1, shall withstand, without breaking into two pieces, a minimum of eight (8) reverse bends.

8.4 *Annealability*—Annealability is not a requirement of this specification. However, a discussion will be found in Notes X1.4-X1.6.

9. Other Requirements

9.1 *Surface Oxide*—The surface oxide film thickness shall be determined in accordance with 13.5.

9.1.1 ~~Total~~ 9.1.1 Total thickness of the copper oxide film on cleaned copper rod or annealed shaved rod or cold-finished rod shall not exceed 750 \AA ($7.5 \times 10^{-7-8} \text{ m}$).

9.1.2 The residual oxide film thickness on as-shaved rod does not need to be specified.

9.1.3 A surface oxide requirement is not necessary for rod ordered uncleaned.

9.2 *Diameter*—The diameter of the rod at any point shall not vary from that specified by more than the amounts prescribed in Table 2.

9.3 *Electromagnetic (Eddy-current) Examination*—~~Electromagnetic examination of copper redraw rod is not a requirement of this specification. If it is performed for detecting surface discontinuities, however, a discussion will be found in Note X1.7.~~

10. Workmanship, Finish and Appearance

10.1 The rod shall be free of defects, but blemishes of a nature that do not interfere with the intended application are acceptable.

11. Sampling

11.1 This procedure shall be used in case of rod dispute between the manufacturer and the purchaser.

11.2 One sample shall be taken from each ~~200000-lb (90000-kg) truck~~ lot for resistivity, elongation, surface oxide, embrittlement (bend) test, and chemical analysis.

11.3 When a cast refinery shape has been chemically analyzed and converted into rod without remelting, further chemical analysis shall not be required.

12. Number of Tests and Retests

12.1 *Tests:*

12.1.1 *Chemical Analysis*—Chemical composition shall be determined as per the element mean of the results from at least two replicate analyses of the sample(s).

TABLE 2 Permissible Variations in Diameter

Nominal Diameter, in. (mm)	Permissible Variation, in. (mm)
¼ (6.4)	+0.020 (+0.51) −0.010 (−0.25)
Over ¼ (6.4) to ¾ in. (19 mm) incl.	±0.015 (±0.38)
Over ¾ (19) to 1.0 in. (25 mm) incl.	±0.020 (±0.51)
Over 1.0 (25) to 1½ in. (35 mm) incl.	±0.030 (±0.76)

TABLE 3 Equivalent Resistivity Values^A

Conductivity at 68°F (20°C), % IACS	100.00	101.00
$\Omega \cdot \text{lb}/\text{mile}^2$	875.20	866.53
$\Omega \cdot \text{g}/\text{m}^2$	0.153 28	0.151 76
$\Omega \cdot \text{c mil}/\text{ft}$	10.371	10.268
$\Omega \cdot \text{mm}^2/\text{m}$	0.017 241 0	0.017 070
$\mu\Omega \cdot \text{in.}$	0.678 79	0.672 07
$\mu\Omega \cdot \text{cm}$	1.7241	1.7070

^A The equivalent resistivity values for 100 % IACS (soft copper) were each computed from the fundamental IEC value ($1/58 \Omega \cdot \text{mm}^2/\text{m}$) using conversion factors each accurate to at least seven significant figures.

12.1.2 Other Tests:

12.1.2.1 *Electrical Resistivity, Elongation, and Surface Oxide*—Results shall be reported as the average obtained from at least two test specimens, each taken from a separate test piece where possible.

12.1.2.2 *Hydrogen Embrittlement Test and Microscopical Examination*—All specimens tested must meet the requirements of the specification.

12.2 Retests:

12.2.1 When requested by the manufacturer or supplier, a retest shall be permitted when results of tests obtained by the purchaser fail to conform to the requirements of the product specification.

12.2.2 The retest shall be as directed in the product specification for the initial test except the number of test specimens shall be twice that normally required for the specified test.

12.2.3 All test specimens shall conform to the product specification requirement(s) in retest. Failure to conform shall be cause for rejection.

13. Test Methods

13.1 Chemical Analysis:

13.1.1 In case of dispute, determine copper content of the coppers other than UNS C10100 and UNS C11040 in Table 1 in accordance with Test Method E53.

13.1.2 Analytical method for determining impurity levels of coppers listed in Table 1 shall be in accordance with Specification B115.

13.1.3 Calculate copper content of UNS C10100 and UNS C11040 types by subtracting from 100 % the total impurity concentration determined. The impurity total for UNS C10100 is defined as the sum of sulfur, silver, lead, tin, bismuth, arsenic, antimony, iron, nickel, zinc, phosphorus, selenium, tellurium, manganese, cadmium, and oxygen present in the sample. The impurity total for UNS C11040 is defined as the sum of sulfur, silver, lead, tin, bismuth, arsenic, antimony, iron, nickel, selenium, tellurium, and oxygen present in the sample.

13.1.4 The test methods annex of Specification B170 should be referenced for the oxygen-free coppers. Test Method E478 should be referenced for the determination of silver-bearing alloys permitted under this specification.

13.1.5 ~~Oxygen content is determined on cleaned copper samples using a suitable laboratory apparatus or a commercial instrument designed specifically for this purpose. An ASTM method has not been developed.~~

13.1.5 Oxygen content is determined on cleaned copper samples using a suitable laboratory apparatus or a commercial instrument designed specifically for this purpose. Test Method E2575 has been developed to determine oxygen content in copper and copper alloys for the range 5 to 400 ppm. Standards have not been developed above this range.

13.2 *Elongation*—Determine the elongation as the permanent increase in length, caused by breaking of the rod in tension, measured between gage marks placed originally 10 in. (250 mm) apart upon the test specimen (Note X1.2). The fracture shall be between gage marks and not closer than 1 in. (25 mm) to either gage mark.

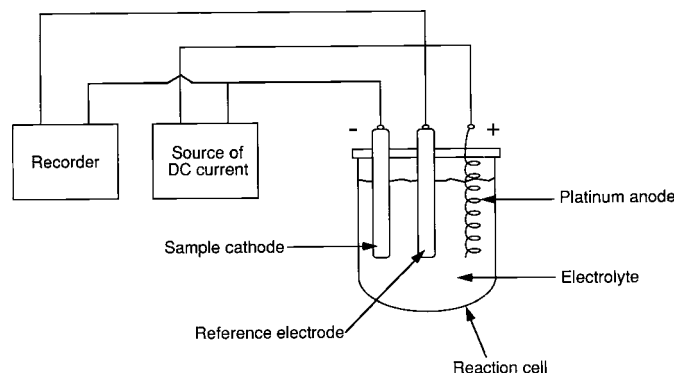

FIG. 1 Schematic Illustration Showing Electrolytic Reduction Test Method