**Ships and marine technology —
Aquatic nuisance species —**

**Part 1:
Ballast water discharge sample port**

Navires et technologie maritime — Espèces aquatiques nuisibles —

Partie 1: Appareillage de prélèvement à l'évacuation de l'eau de ballast

<https://standards.iteh.ai>
Document Preview

ISO 11711-1:2019

<https://standards.iteh.ai/catalog/standards/iso/34c05d91-558c-43de-a1e2-f82d820bbf90/iso-11711-1-2019>



iTeh Standards
(<https://standards.iteh.ai>)
Document Preview

[ISO 11711-1:2019](https://standards.iteh.ai/catalog/standards/iso/34c05d91-558c-43de-a1e2-f82d820bbf90/iso-11711-1-2019)

<https://standards.iteh.ai/catalog/standards/iso/34c05d91-558c-43de-a1e2-f82d820bbf90/iso-11711-1-2019>



COPYRIGHT PROTECTED DOCUMENT

© ISO 2019

All rights reserved. Unless otherwise specified, or required in the context of its implementation, no part of this publication may be reproduced or utilized otherwise in any form or by any means, electronic or mechanical, including photocopying, or posting on the internet or an intranet, without prior written permission. Permission can be requested from either ISO at the address below or ISO's member body in the country of the requester.

ISO copyright office
CP 401 • Ch. de Blandonnet 8
CH-1214 Vernier, Geneva
Phone: +41 22 749 01 11
Fax: +41 22 749 09 47
Email: copyright@iso.org
Website: www.iso.org

Published in Switzerland

Contents

	Page
Foreword	iv
Introduction	v
1 Scope	1
2 Normative references	1
3 Terms and definitions	1
4 Sample port design	3
4.1 Colour.....	3
4.2 Labelling.....	3
4.3 Ancillary piping design and installation.....	3
4.4 Materials.....	4
4.5 Welding.....	4
4.6 Configuration of the sample port assembly.....	4
4.6.1 General.....	4
4.6.2 Sample port.....	4
4.6.3 Return port.....	5
4.7 Location of the sample port and return port.....	8
4.7.1 General.....	8
4.7.2 Location of the sample port based on hydrodynamic conditions.....	8
4.7.3 Location of the sample and return ports based on the availability of space.....	8
4.8 Safety considerations.....	8
Annex A (informative) Installation of sample ports for ships with ballast discharge pipes <DN100	10
Annex B (informative) Installation of a sample port for ballast water samples from an uptake operation	11
Bibliography	12

<https://standards.iteh.ai>

<https://standards.iteh.ai/catalog/standards/iso/34c05d91-558c-43de-a1e2-f82d820bbf90/iso-11711-1-2019>

Foreword

ISO (the International Organization for Standardization) is a worldwide federation of national standards bodies (ISO member bodies). The work of preparing International Standards is normally carried out through ISO technical committees. Each member body interested in a subject for which a technical committee has been established has the right to be represented on that committee. International organizations, governmental and non-governmental, in liaison with ISO, also take part in the work. ISO collaborates closely with the International Electrotechnical Commission (IEC) on all matters of electrotechnical standardization.

The procedures used to develop this document and those intended for its further maintenance are described in the ISO/IEC Directives, Part 1. In particular the different approval criteria needed for the different types of ISO documents should be noted. This document was drafted in accordance with the editorial rules of the ISO/IEC Directives, Part 2 (see www.iso.org/directives).

Attention is drawn to the possibility that some of the elements of this document may be the subject of patent rights. ISO shall not be held responsible for identifying any or all such patent rights. Details of any patent rights identified during the development of the document will be in the Introduction and/or on the ISO list of patent declarations received (see www.iso.org/patents).

Any trade name used in this document is information given for the convenience of users and does not constitute an endorsement.

For an explanation on the voluntary nature of standards, the meaning of ISO specific terms and expressions related to conformity assessment, as well as information about ISO's adherence to the World Trade Organization (WTO) principles in the Technical Barriers to Trade (TBT) see the following URL: www.iso.org/iso/foreword.html.

This document was prepared by Technical Committee ISO/TC 8, *Ships and marine technology*.

This second edition cancels and replaces the first edition (ISO 11711-1:2013), which has been technically revised.

The main changes compared to the previous edition are as follows:

- The previous edition did not address apparatus needed to collect representative samples of ballast water, nor did it provide procedures for handling or analysing the samples after they have been collected. Accordingly, this second edition of ISO 11711-1 is intended to be complemented with other two Parts in the ISO 11711 series.
- The previous edition provided guidance on the design of "sample ports;" they are now known as "sample probes."
- This edition clarifies issues encountered with the previous edition and provides additional information:
 - A semi-permanently installed probe could become hazardous to ship operations if there is excessive bio-fouling in or corrosion of the pipe.
 - The first edition did not contain sufficient details to allow for multiple available sample probe configurations and installation methods.
- The end user is now addressed in each of the parts of the ISO 11711 series. For example, this document is intended for ship owners, designers and crew for accessing the main ballast pipe for sampling; ISO 11711-2 is intended for port state control or other sampling parties; a future Part will be intended for personnel analysing the samples.

A list of all the parts in the ISO 11711 series can be found on the ISO website.

Any feedback or questions on this document should be directed to the user's national standards body. A complete listing of these bodies can be found at www.iso.org/members.html.

Introduction

This document provides guidance to shipboard personnel and other concerned parties on designs, installations and procedures required to obtain representative samples of ballast water from the ballast water discharge piping prior to discharge. ISO 11711-1 defines arrangements for shipboard ballast piping and fittings that are independent of the sampling apparatus used by sampling teams. ISO 11711-2¹⁾ will provide guidance on the selection and use of sampling apparatus needed to collect and process the samples on board the vessel. These concepts are illustrated in [Figure 1](#). A future part will provide methodologies to analyse the samples and determine compliance with ballast water discharge regulations.

Sampling is intended to determine whether ballast water is in compliance with regulatory discharge standards, such as during the installation or evaluation of ballast water treatment equipment, periodic ballast water discharge assessments or during a port state control inspection of the ballast water being discharged.

The sampling guidance provided by the ISO 11711 series is intended to support measurement of organism counts in ballast discharge piping consistent with the requirements of the International Maritime Organisation (IMO) D-2 discharge standard. Such measurement requires the collection and analysis of representative samples, i.e. the makeup of the sample is representative of the water flowing in the ballast pipe over the period of sample collection.

The guidance provided by the ISO 11711 series is valid only for turbulent flows within the ballast discharge pipe. Selecting appropriate sample probes and controlling sample flows to meet representative sampling constraints will be discussed in ISO 11711-2.

(<https://standards.iteh.ai>)
Document Preview

[ISO 11711-1:2019](#)

<https://standards.iteh.ai/catalog/standards/iso/34c05d91-558c-43de-a1e2-f82d820bbf90/iso-11711-1-2019>

1) Under development.

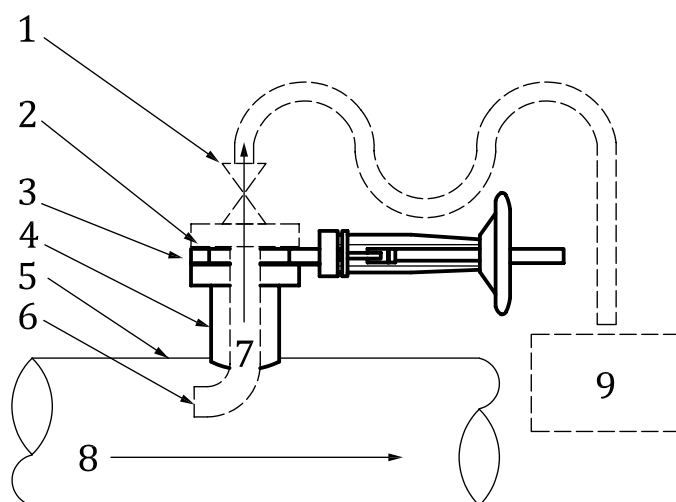

Key

- | | | | |
|---|----------------------------------|---|--------------------------|
| 1 | sample collection device valve | 6 | sample probe |
| 2 | sample port access flange | 7 | sample water flow |
| 3 | sample port valve | 8 | ballast water flow |
| 4 | sample port | 9 | sample collection device |
| 5 | ballast main pipe | | |

————— ISO 11711-1 - BALLAST WATER SAMPLE PORT - FITTING ARRANGEMENTS

----- ISO 11711-2 - ON-BOARD BALLAST WATER SAMPLING AND SAMPLE PROCESSING

NOTE 1 Figure not to scale.

NOTE 2 The figure shows a sample port arranged perpendicular to the main ballast flow.

Figure 1 — Illustration of the Scopes of ISO 11711-1 and ISO 11711-2

<https://standards.iteh.ai/catalog/standards/iso/34c05d91-558c-43de-a1e2-f82d820bb190/iso-11711-1-2019>

Ships and marine technology — Aquatic nuisance species —

Part 1: Ballast water discharge sample port

1 Scope

This document specifies requirements for the design and the fitting arrangements of ballast water discharge sample ports.

In coordination with the vessel, a suitable sample collection probe is installed into the shipboard sample port as needed to collect ballast samples, and the port is sealed with a blind flange at other times. This document addresses the location of sample ports to accommodate representative sampling, and it standardizes the presentation of the port to accommodate various probe configurations. It provides specifications for a return port to the ballast line downstream of the sample collection port, allowing processed sample water to be returned to the ballast pipe. The appropriate sample probe and other sample collection apparatus is determined by the sample collection team according to the requirements of ISO 11711-2.

NOTE The distinction between the sample *port* discussed in this document and the sample *probe* discussed in ISO 11711-2 is worth noting. The sample port is a permanent apparatus designed and installed in the ship's ballast piping to accept multiple sample probe configurations. The sample probe is a temporarily installed water collection pipe designed by the sampling party to mate with the sample port and to meet the measurement objectives of the sample.

This document is applicable to ships with a ballast discharge pipe size of DN 100 or greater, with turbulent flows. Guidance for smaller ballast pipe diameters is given in [Annex A](#).

This document primarily addresses the collection of ballast water *discharge* samples. Optional requirements for installation of sample ports intended to collect *uptake* samples are provided in [Annex B](#).

2 Normative references

The following documents are referred to in the text in such a way that some or all of their content constitutes requirements of this document. For dated references, only the edition cited applies. For undated references, the latest edition of the referenced document (including any amendments) applies.

ISO 7005-1, *Pipe flanges — Part 1: Steel flanges for industrial and general service piping systems*

ISO 14726, *Ships and marine technology — Identification colours for the content of piping systems*

ISO 15614 (all parts), *Specification and qualification of welding procedures for metallic materials — Welding procedure test*

ISO 17602, *Ships and marine technology — Metal valves for use in flanged pipe — Face-to-face and centre-to-face dimensions*

3 Terms and definitions

For the purposes of this document, the following terms and definitions apply.

ISO 11711-1:2019(E)

ISO and IEC maintain terminological databases for use in standardization at the following addresses:

- IEC Electropedia: available at <http://www.electropedia.org/>
- ISO Online browsing platform: available at <https://www.iso.org/obp>

3.1

ballast discharge pipe

primary pipe used to transfer water between a ship's ballast tanks and overboard discharge

3.2

ballast water

water with its suspended matter taken on board a ship to control trim, list, stability or stresses of the ship

3.3

ballast water system

arrangement of pumps, piping and tanks on ships used to control trim, list, stability or stresses of the ship

3.4

ballast water management system

BWMS

equipment that processes *ballast water* (3.2) such that the water discharged (the treated water) is intended to meet the specified performance requirements for eliminating or reducing aquatic organisms

3.5

blind flange

closed end of pipe or *fitting* (3.6), extending perpendicular to its axis with, bolt holes equally spaced in a circle to abut with another *flange* (3.7) and isolate a section of pressurized piping

[SOURCE: ISO 2531:2009, 3.10, definition of "flange", modified - "closed" added at the beginning of the definition, and "to abut with another flange and isolate a section of pressurized piping" added at the end.]

3.6

fitting

component other than a pipe, which allows pipeline deviation, change of direction or bore

[SOURCE: ISO 2531:2009, 3.9, modified - "casting" replaced by "component", and Note deleted.]

3.7

flange

end of a pipe or fitting, extending perpendicular to its axis, with opening and bolt holes equally spaced in a circle to abut with another flange

[SOURCE: ISO 2531:2009, 3.10, modified - "opening and" and "to abut with another flange" added.]

3.8

full port valve

full bore valve

valve designed such that flow is unrestricted when it is open

3.9

gasket

sealing component of a joint between two *flanges* (3.7)

[SOURCE: ISO 2531:2009, 3.13, modified - "between two flanges" added.]

3.10

isolation valve

full port valve (3.8) with flanged faces installed on the *sample port* (3.14) to allow sealing of the sampling access and installation of a *sample probe* (3.15)

3.11 nominal size

DN

nominal pipe size

NPS

alphanumeric designation of size for components of a pipework system, which is used for reference purposes

Note 1 to entry: It comprises the letters DN (when relating to millimetres) or NPS (when relating to inches) followed by a dimensionless whole number, which is indirectly related to the physical size of the bore or outside diameter of the end connections.

[SOURCE: ISO 2531:2009, 3.20, definition of "nominal size, DN", and ISO 13703:2000, 3.1.15, reworded.]

3.12 return port

flanged opening that provides a means to return processed water to the ballast pipe downstream of the *sample port* (3.14)

Note 1 to entry: It does not necessarily accommodate the insertion of a *sample probe* (3.15).

3.13 sample collection device

device that can concentrate and collect the larger class of organisms (via a filter or plankton net), collect a whole water sample, or both

3.14 sample port

flanged opening for inserting a *sample probe* (3.15) into the ballast pipe

3.15 sample probe

tube inserted into the *ballast discharge pipe* (3.1) through the *sample port* (3.14) that provides the ability to connect to external piping for collection and processing of a *ballast water* (3.2) sample

Note 1 to entry: Further specifications of the sample probes will be provided in ISO 11711-2.

3.16 treatment

process or combination of mechanical, physical or chemical methods to kill, remove or render harmless organisms within *ballast water* (3.2)

4 Sample port design

4.1 Colour

The sample port, return port and any associated piping, particularly valve handles, shall be appropriately coloured green in accordance with ISO 14726 to indicate a sea water system.

4.2 Labelling

The sample port and return port shall be labelled with tags or markings to explicitly distinguish their functions. The labels shall be clearly visible from personnel standing at the ground level platform or at the deck in the area where the ports are located.

4.3 Ancillary piping design and installation

Where particulars are unspecified, the design and installation of the sample port, return port and any associated piping systems shall be in accordance with classification society rules or other international

or national standards approved by the authority having jurisdiction in ship modifications. This includes selection of components used in the installations.

4.4 Materials

In order to prevent galvanic corrosion and potential leaking or flooding, the sample port flange, piping, valves and blind flange shall be constructed of the same or galvanically compatible material as the ballast water piping, and they shall be mechanically suitable for long-term installation. Extra strong schedule piping and fittings shall be used.

4.5 Welding

Welding and workmanship of all piping and equipment shall be in accordance with ISO 15614, classification society rules or other international or national standards approved by the authority having jurisdiction in ship modifications. All welded joints shall be pressure rated to the specifications of the vessel's ballast water system.

4.6 Configuration of the sample port assembly

4.6.1 General

Sample ports may be installed in three (3) orientations relative to the centre axis of the ballast discharge pipe to be sampled: perpendicular ([Figure 2](#)), at 45 ° ([Figure 3](#)) and inline ([Figure 4](#)). For the perpendicular or inline configurations, the sample port may be located at any point around the circumference of the ballast discharge pipe that provides acceptable clearances.

NOTE A sample port perpendicular or at 45 ° from the central axis of the ballast discharge pipe is installed on a straight section of the piping. An inline sample port is installed in the side of a piping elbow or tee.

For the purpose of connecting a sample collection device, two (2) ports are required on a ballast discharge pipe. A sample port is used to install the sample probe, which provides the sample water to the collection device. A return port is used to return the processed sample water downstream of the sample port into the ballast discharge pipe. Sizing, location and configuration of each port depends on its function.

4.6.2 Sample port

The sample port shall be installed on all vessels using standard schedule piping and fittings. A pipe boss, saddle or other suitable method shall be used to provide access to the inside of the ballast discharge pipe ([Figures 2 to 4](#)). Only straight fittings shall be used and the inside of the access shall be unobstructed to the ballast discharge pipe with internal edges smoothed and de-burred.

A knife-style gate valve, referred to as the sample port valve in [Figures 2 to 4](#), shall be provided to allow the sample port to be closed off from the ballast discharge pipe. The sample port valve, used with a flanged pipe, shall be fully ported, such that a clear and straight opening is provided from the access flange into the ballast discharge pipe when the valve is fully open (see [Table 1](#)). The valves shall be of standard design with dimensions in accordance with ISO 17602.

An access flange shall be provided to allow the sample probe and associated apparatus to be installed in the sample port. The access flange shall be of standard design to ISO 7005-1 PN 20 DN 100 (identical dimensionally to DIN 2544 PN 20, ASME B16.5 class 150 or JIS B2220 16K). Flanges shall be flat face. It is acceptable to utilize a flanged isolation valve as the access flange provided it meets the ISO 7005-1 PN 20 DN 100 standard. The distance from the ballast discharge pipe inner wall to the face of the access flange is identified in the figures as dimension *B* and shall not exceed the values shown in [Table 1](#).

When the sample port is not in use, the sample port valve shall remain closed and the access flange shall be covered with a blind flange.