

SLOVENSKI STANDARD

SIST-TP CEN/TR 12098-6:2023

01-februar-2023

Nadomešča:

SIST-TP CEN/TR 12098-6:2018

SIST-TP CEN/TR 12098-8:2018

**Energijske lastnosti stavb - Naprave za regulacijo sistemov za ogrevanje - 6. del:
Razlaga in utemeljitev TR EN 12098-1:2022 - Moduli M3-5, 6, 7, 8**

Energy performance of buildings - Controls for heating systems - Part 6: Accompanying
TR EN 12098-1:2022 - Modules M3-5,6,7,8

Energieeffizienz von Gebäuden - Mess-, Steuer- und Regeleinrichtungen für Heizungen -
Teil 6: Begleitender TR zu EN 12098-1:2022 - Module M3-5,6,7,8

<https://standards.iteh.ai/catalog/standards/sist/4b8803c0-252d-4e09-a4c5-913a2a85215d/sist-tp-cen-tr-12098-6-2023>

Ta slovenski standard je istoveten z: CEN/TR 12098-6:2022

ICS:

91.140.10	Sistemi centralnega ogrevanja	Central heating systems
97.120	Avtomatske krmilne naprave za dom	Automatic controls for household use

SIST-TP CEN/TR 12098-6:2023 en,fr,de

TECHNICAL REPORT

CEN/TR 12098-6

RAPPORT TECHNIQUE

TECHNISCHER REPORT

November 2022

ICS 91.140.10; 97.120

Supersedes CEN/TR 12098-6:2016, CEN/TR 12098-8:2016

English Version

Energy performance of buildings - Controls for heating systems - Part 6: Accompanying TR EN 12098-1:2022 - Modules M3-5,6,7,8

Energieeffizienz von Gebäuden - Mess-, Steuer- und Regeleinrichtungen für Heizungen - Teil 6:
Begleitender TR zu EN 12098-1:2022 - Module M3-5,6,7,8

This Technical Report was approved by CEN on 23 October 2022. It has been drawn up by the Technical Committee CEN/TC 247.

CEN members are the national standards bodies of Austria, Belgium, Bulgaria, Croatia, Cyprus, Czech Republic, Denmark, Estonia, Finland, France, Germany, Greece, Hungary, Iceland, Ireland, Italy, Latvia, Lithuania, Luxembourg, Malta, Netherlands, Norway, Poland, Portugal, Republic of North Macedonia, Romania, Serbia, Slovakia, Slovenia, Spain, Sweden, Switzerland, Türkiye and United Kingdom.

(standards.iteh.ai)

[SIST-TP CEN/TR 12098-6:2023](https://standards.iteh.ai/catalog/standards/sist/4b8803c0-252d-4e09-a4c5-913a2a85215d/sist-tp-cen-tr-12098-6-2023)

<https://standards.iteh.ai/catalog/standards/sist/4b8803c0-252d-4e09-a4c5-913a2a85215d/sist-tp-cen-tr-12098-6-2023>



EUROPEAN COMMITTEE FOR STANDARDIZATION
COMITÉ EUROPÉEN DE NORMALISATION
EUROPÄISCHES KOMITEE FÜR NORMUNG

CEN-CENELEC Management Centre: Rue de la Science 23, B-1040 Brussels

Contents	Page
European foreword.....	3
Introduction	4
1 Scope	6
2 Normative references	6
3 Terms and definitions	6
4 Symbols and abbreviations	6
4.1 Symbols.....	6
4.2 Abbreviations	6
5 Control heating systems, main design rules	7
5.1 Control heating systems, main design rules, general.....	7
5.2 Partitioning control heating zones in buildings	7
5.2.1 General.....	7
5.2.2 Emission control.....	8
6 Control heating functions and their impact	9
6.1 Flow temperature control.....	9
6.1.1 General.....	9
6.1.2 OTC generation and storage impact.....	10
6.1.3 OTC control distribution impact.....	10
6.1.4 OTC control emission impact.....	11
6.2 Auto tuning heating curve parameters	11
6.3 Compensation by emitters energy demand transmission	11
6.4 Other meteorological variables and forecast	11
6.5 Optimum Start-stop scheduling.....	11
6.5.1 General.....	11
6.5.2 OSS generation and storage impact.....	11
6.5.3 OSS distribution impact	12
6.5.4 OSS emission impact	13
6.6 Summer-winter switch.....	13
6.7 Pumps control	13
7 Integrated functions in control systems and their impact	14
7.1 Integrated functions.....	14
7.2 Central control effect on room temperature control	14
7.2.1 General.....	14
7.2.2 Flow temperature control accuracy	15
7.2.3 Heating curve adaptation.....	15
7.2.4 Calculating contribution of central control to emission control.....	15
Annex A (informative) Applications of heating control functions for buildings	18
Bibliography	20

European foreword

This document (CEN/TR 12098-6:2022) has been prepared by Technical Committee CEN/TC 247 “Building Automation, Controls and Building Management”, the secretariat of which is held by SNV.

Attention is drawn to the possibility that some of the elements of this document may be the subject of patent rights. CEN shall not be held responsible for identifying any or all such patent rights.

This document supersedes CEN/TR 12098-6:2016 and CEN/TR 12098-8:2016.

The most important changes in comparison with CEN/TR 12098-6:2016 are:

- respecting the presentation of this project in the frame EPB in accordance with the drafting rules;
- improvements in line with EN 12098-5:2017.

Any feedback and questions on this document should be directed to the users’ national standards body. A complete listing of these bodies can be found on the CEN website.

iTeh STANDARD PREVIEW
(standards.iteh.ai)

[SIST-TP CEN/TR 12098-6:2023](https://standards.iteh.ai/catalog/standards/sist/4b8803c0-252d-4e09-a4c5-913a2a85215d/sist-tp-cen-tr-12098-6-2023)

<https://standards.iteh.ai/catalog/standards/sist/4b8803c0-252d-4e09-a4c5-913a2a85215d/sist-tp-cen-tr-12098-6-2023>

CEN/TR 12098-6:2022 (E)**Introduction**

This document is part of the set of EPB (Energy Performance of Building) standards that aim to support the implementation of the Energy Performance of Buildings Directive (EPBD). This document contains informative content for users to properly understand, apply and nationally adapt the EPB standards.

This document follows the basic principles (CEN/TS 16628, *Energy Performance of Buildings — Basic Principles for the set of EPB standards*) and detailed technical rules (CEN/TS 16629, *Energy Performance of Buildings — Detailed Technical Rules for the set of EPB-standards*) elaborated by CEN.

The detailed technical rules CEN/TS 16629 ask for a clear separation between normative and informative contents:

- to avoid flooding and confusing the actual normative part with informative content;
- to reduce the page count of the actual standard;
- to facilitate understanding of the package.

Therefore, each EPB standard should be accompanied by an informative technical report, like this one, where all informative content is collected.

Table 1 shows the relative position of this document within the EPB set of standards.

iTeh STANDARD PREVIEW
(standards.iteh.ai)

SIST-TP CEN/TR 12098-6:2023

<https://standards.iteh.ai/catalog/standards/sist/4b8803c0-252d-4e09-a4c5-913a2a85215d/sist-tp-cen-tr-12098-6-2023>

Table 1 — Position of this document (in casu M3–5, 6, 7, 8), within the modular structure of the set of EPB standards

Submodule	Overarching	Building (as such)	Technical Building System									
	Descriptions	Descriptions	Descriptions	Heating	Cooling	Ventilation	Humidification	Dehumidification	Domestic Hot waters	Lighting	Building automation and control	PV, wind...
sub1	M1	M2		M3	M4	M5	M6	M7	M8	M9	M10	M11
1	General	General	General									
2	Common terms and definitions; symbols, units and subscripts	Building Energy Needs	Needs									
3	Application	(Free) Indoor Conditions without Systems	Maximum Load and Power									
4	Ways to Express Energy Performance	Ways to Express Energy Performance	Ways to Express Energy Performance									
5	Building Functions and Building Boundaries	Heat Transfer by Transmission	Emission and control	x								
6	Building Occupancy and Operating Conditions	Heat Transfer by Infiltration and Ventilation	Distribution and control	x								
7	Aggregation of Energy Services and Energy Carriers	Internal Heat Gains	Storage and control	x								
8	Building Partitioning	Solar Heat Gains	Generation and control	x								
9	Calculated Energy Performance	Building Dynamics (thermal mass)	Load dispatching and operating conditions									
10	Measured Energy Performance	Measured Energy Performance	Measured Energy Performance									
11	Inspection	Inspection	Inspection									
12	Ways to Express Indoor Comfort		BMS									
13	External Environment Conditions											
14	Economic Calculation											

NOTE The shaded modules are not applicable.

CEN/TR 12098-6:2022 (E)**1 Scope**

This document refers to EN 12098-1:2022, *Energy performance of buildings — Controls for heating systems — Part 1: Control equipment for hot water heating systems — Modules M3-5, 6, 7, 8*.

It contains information to support the correct understanding, use and national adaption of EN 12098-1:2022.

This document does not contain any normative provisions.

2 Normative references

The following documents are referred to in the text in such a way that some or all of their content constitutes requirements of this document. For dated references, only the edition cited applies. For undated references, the latest edition of the referenced document (including any amendments) applies.

EN 12098-1:2022, *Energy performance of buildings — Controls for heating systems — Part 1: Control equipment for hot water heating systems — Modules M3-5, 6, 7, 8*

EN ISO 7345, *Thermal performance of buildings and building components — Physical quantities and definitions (ISO 7345)*

EN ISO 52000-1:2017, *Energy performance of buildings — Overarching EPB assessment — Part 1: General framework and procedures (ISO 52000-1)*

EN ISO 52120-1:2022, *Energy performance of buildings — Contribution of building automation, controls and building management — Part 1: General framework and procedures (ISO 52120-1)*

3 Terms and definitions

For the purposes of this document, the terms and definitions given in EN ISO 7345, EN ISO 52000-1:2017, EN 12098-1:2022 and EN ISO 52120-1:2022 apply.

ISO and IEC maintain terminology databases for use in standardization at the following addresses:

- ISO Online browsing platform: available at <https://www.iso.org/obp>
- IEC Electropedia: available at <https://www.electropedia.org/>

4 Symbols and abbreviations**4.1 Symbols**

For the purposes of this document, the symbols given in EN ISO 52000-1:2017 and EN 12098-1:2022 apply.

4.2 Abbreviations

Table 2 shows the abbreviations used in this document.

Table 2 — Abbreviations

Abbreviations	Explanation
OTC	outside temperature compensated
RTC	room temperature control
FSS	fixed start-stop scheduling
OSS	optimum start-stop scheduling
TRV	thermostatic radiator valve

5 Control heating systems, main design rules

5.1 Control heating systems, main design rules, general

An efficient heating control system consists of integrated functions applied to all parts of the water heating system: emission or room control by TRV or RTC, flow temperature control by OTC control, FSS, OSS, pumps and generators sequencing and controls, thermal storage management, cost optimization of thermal resources taking account of smart metering, predictable or detected occupancy.

5.2 Partitioning control heating zones in buildings

5.2.1 General

To efficiently control heating, the flow temperature level of the generation and distribution system should satisfy heat demand to the lowest flow temperature. For this purpose, flow temperature is compensated by outside temperature and scheduled for intermittent heating in relation to conditions of use. For efficiency of control systems:

- The heating system distribution building should be partitioned into zones or spaces with uniform conditions of use.

Partitioning of heating systems described in EN ISO 52000-1:2017, Clause 10, D.2, D.3, may usefully be applied for the design of heating systems.

- The zone partitioning of the building should take into account thermal characteristics of emitters (all identical emitters) of a zone.
- BAC heating control system should have multiple controls and intermittent scheduling adapted to zones or spaces conditions of use. Special attention should be given to keep watch for update set points and schedulers to real conditions of use and needs, during exploitation.

To satisfy these indications, size of zones should be limited.

NOTE 1 An indication is given in EN 15316-3:2017, A.2: limit zones area to 1 000 m² (one pump for a maximum of 1 000 m²).

As a general rule, heating control systems involves integrating many functions applied to central (generation, storage), zone (distribution) and room (emission) parts of heating systems.

OTC control, OSS and complementary integrated functions are specified in EN 12098-1:2022 and fulfil items in EN ISO 52120-1:2022, Table 5, functions 1.1 to 1.10.

NOTE 2 Better control and scheduling of heating systems imply a data communication network linking control devices for integration of these functions and other technical building management capabilities for energy performance.

For these parts, objectives of control functions are the lowest flow temperature, the longest reduced or stop heat generation periods, and pumps operation.

Generation (see EN 15316-4-1) and distribution (see EN 15316-3:2017) parts are controlled acting water flow temperature whilst emission is controlled via the flow through emitters.

These central controls apply to buildings, zones, and spaces (see Figure 1), taking into account thermal characteristics and conditions of use (see EN ISO 52000-1:2017).

Emitters of a zone or space controlled by an OTC controller should be of the same model, for conformity with a single heating curve shape common to all emitters of the controlled zone, i.e. do not mix different types of steel radiators, heating floor or fan coil on a distribution controlled by an OTC controller.

CEN/TR 12098-6:2022 (E)**5.2.2 Emission control**

Individual control of emitters or RTC completes central control by individual emitter's controllers acting flow through emitters. The aim of individual control consists in adapting conditions of operation (individual set point, individual scheduling) to consumers' needs (see EN ISO 52120-1:2022, Figure 3) and to compensate room heat gains, reducing heating for comfort and energy saving.

However, individual room temperature control performance does not depend only on individual controllers; it depends also on the flow temperature central (generation, distribution) control, mainly for these cases:

- Emitters are not equipped with efficient electronic individual RTC (conform to EN 15500-1:2017).
- Users are not encouraged to adapt the set point of their room temperature controller considering their comfort needs related to energy consumption.
- Heated rooms or spaces do not permit to measure a representative temperature for individual (closed loop) RTC, e.g.: entrance, corridor, reception hall, exhibition hall, atrium. Emission control is operated only by the flow temperature control (generation, distribution parts).

However:

- For accuracy of a room controller, the flow temperature of emitters should be adapted to the heating load, i.e. related to the main influence, the outside temperature. OTC control improves control efficiently of individual controllers limiting the role of these controllers to compensate heat gains and avoiding hanging process of these closed control loops.
- To avoid energy wasting by unusual use, inattentive settings or defaults of room controllers, the central OTC control limit the higher room temperature able to be reached.

EXAMPLE Room temperature able to be reached by OTC control may be limited to 22 °C, room controller reduces this level, modulating flow through emitter.

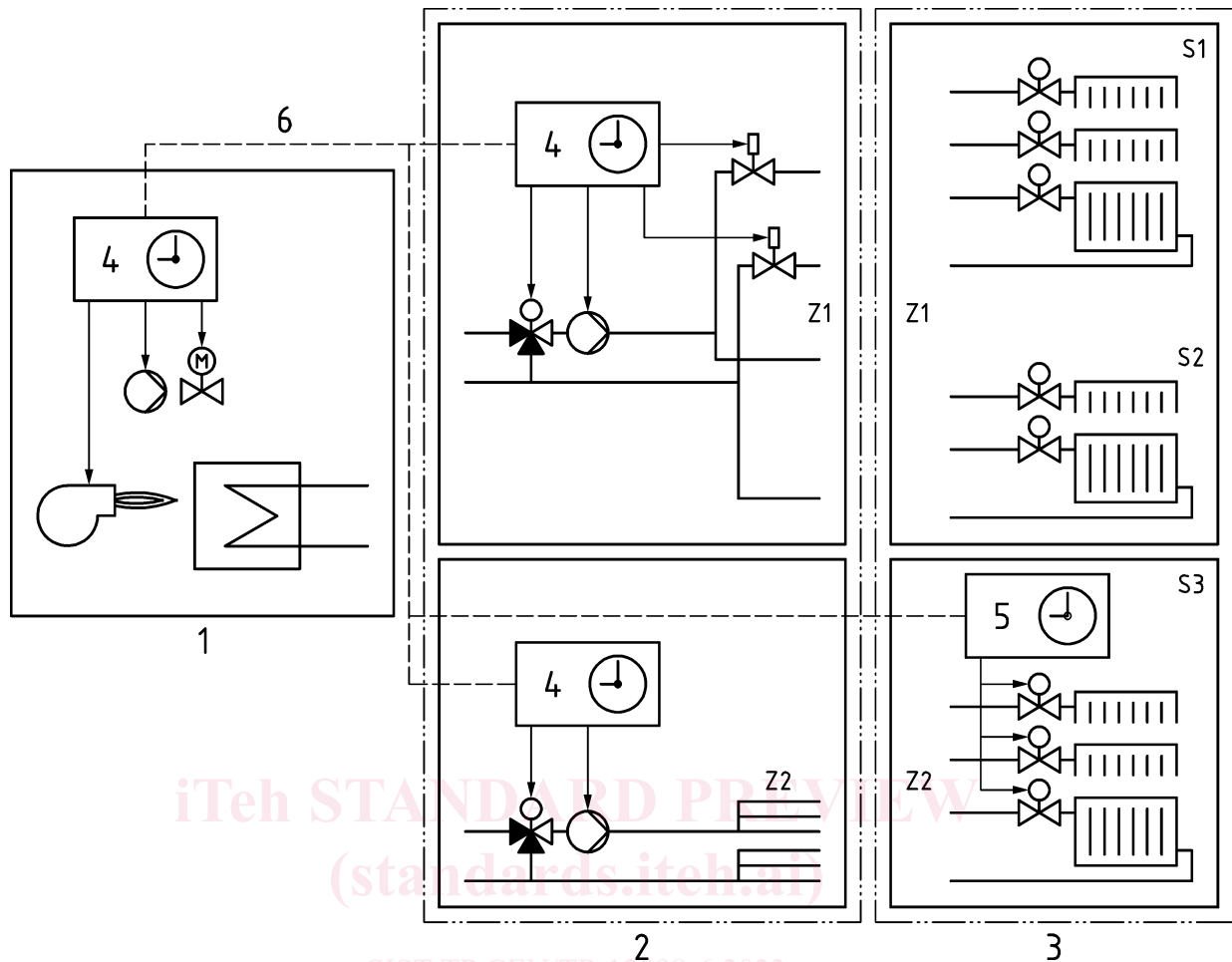
**Key**

- 1 generation
 2 distribution
 3 emission
 4 OTC controller
 5 electronic room controller
 S1, S2, S3 elementary spaces
 Z1, Z2 zones

SIST-TP CEN/TR 12098-6:2023

<https://standards.iteh.ai/catalog/standards/sist/4b8803c0-252d-4e09-a4c5-913a2a85215d/sist-tp-cen-tr-12098-6-2023>

Figure 1 — Control heating systems parts**6 Control heating functions and their impact****6.1 Flow temperature control****6.1.1 General**

Water temperature control by OTC control (function in standalone devices or BAC systems) should be applied to generation and distribution parts (see Figure 1).

Annex A gives applications of heating control functions for buildings.