**Fine ceramics (advanced ceramics,
advanced technical ceramics) —
Mechanical properties of ceramic
composites at room temperature
— Determination of compressive
properties**

iTeh STANDARD PREVIEW

(standards.iteh.ai)
*Céramiques techniques — Propriétés mécaniques des composites
à matrice céramiques à température ambiante — Méthode de
détermination des propriétés en compression*

[ISO 20504:2019](https://standards.iteh.ai/catalog/standards/sist/885d2a65-7f90-455c-a49c-a0a1a05c0c2c/iso-20504-2019)

<https://standards.iteh.ai/catalog/standards/sist/885d2a65-7f90-455c-a49c-a0a1a05c0c2c/iso-20504-2019>



iTeh STANDARD PREVIEW
(standards.iteh.ai)

ISO 20504:2019

<https://standards.iteh.ai/catalog/standards/sist/885d2a65-7f90-455c-a49c-a0a1a05c0c2c/iso-20504-2019>



COPYRIGHT PROTECTED DOCUMENT

© ISO 2019

All rights reserved. Unless otherwise specified, or required in the context of its implementation, no part of this publication may be reproduced or utilized otherwise in any form or by any means, electronic or mechanical, including photocopying, or posting on the internet or an intranet, without prior written permission. Permission can be requested from either ISO at the address below or ISO's member body in the country of the requester.

ISO copyright office
CP 401 • Ch. de Blandonnet 8
CH-1214 Vernier, Geneva
Phone: +41 22 749 01 11
Fax: +41 22 749 09 47
Email: copyright@iso.org
Website: www.iso.org

Published in Switzerland

Contents

Page

Foreword.....	iv
1 Scope.....	1
2 Normative references.....	1
3 Terms and definitions.....	1
4 Principle.....	3
5 Apparatus.....	3
5.1 Test machine.....	3
5.2 Load train.....	3
5.3 Strain measurement.....	4
5.3.1 General.....	4
5.3.2 Strain gauges.....	4
5.3.3 Extensometry.....	4
5.4 Data recording system.....	4
5.5 Dimension-measuring devices.....	4
6 Test specimens.....	5
6.1 General.....	5
6.2 Compression between platens.....	5
6.3 Test specimen used with grips.....	7
7 Test specimen preparation.....	10
7.1 Machining and preparation.....	10
7.2 Number of test specimens.....	10
8 Test procedure.....	10
8.1 Test mode and rate.....	10
8.2 Measurement of test specimen dimensions.....	10
8.3 Buckling.....	10
8.4 Testing technique.....	11
8.4.1 Test specimen mounting.....	11
8.4.2 Extensometers.....	11
8.4.3 Measurements.....	11
8.5 Test validity.....	11
9 Calculation of results.....	11
9.1 Test specimen origin.....	11
9.2 Compressive strength.....	12
9.3 Strain at maximum compressive force.....	12
9.4 Proportionality ratio or pseudo-elastic modulus.....	12
10 Test report.....	13
Annex A (informative) Illustration of elastic modulus.....	15
Bibliography.....	17

Foreword

ISO (the International Organization for Standardization) is a worldwide federation of national standards bodies (ISO member bodies). The work of preparing International Standards is normally carried out through ISO technical committees. Each member body interested in a subject for which a technical committee has been established has the right to be represented on that committee. International organizations, governmental and non-governmental, in liaison with ISO, also take part in the work. ISO collaborates closely with the International Electrotechnical Commission (IEC) on all matters of electrotechnical standardization.

The procedures used to develop this document and those intended for its further maintenance are described in the ISO/IEC Directives, Part 1. In particular, the different approval criteria needed for the different types of ISO documents should be noted. This document was drafted in accordance with the editorial rules of the ISO/IEC Directives, Part 2 (see www.iso.org/directives).

Attention is drawn to the possibility that some of the elements of this document may be the subject of patent rights. ISO shall not be held responsible for identifying any or all such patent rights. Details of any patent rights identified during the development of the document will be in the Introduction and/or on the ISO list of patent declarations received (see www.iso.org/patents).

Any trade name used in this document is information given for the convenience of users and does not constitute an endorsement.

For an explanation of the voluntary nature of standards, the meaning of ISO specific terms and expressions related to conformity assessment, as well as information about ISO's adherence to the World Trade Organization (WTO) principles in the Technical Barriers to Trade (TBT) see www.iso.org/iso/foreword.html.

This document was prepared by Technical Committee ISO/TC 206, *Fine ceramics*.

This second edition cancels and replaces the first edition (ISO 20504:2006), which has been technically revised. The main changes to the previous edition are as follows:

- the title has been improved;
- [Clause 1](#), [Clause 2](#), [Clause 3](#), [5.2](#), [5.3](#), [5.4](#), [6.2](#), [8.1](#), [8.3](#), [9.3](#) and [9.4.3](#) have been updated;
- 9.5, 9.6 and 9.7 have been deleted;
- Annexes B and C have been deleted.

Any feedback or questions on this document should be directed to the user's national standards body. A complete listing of these bodies can be found at www.iso.org/members.html.

Fine ceramics (advanced ceramics, advanced technical ceramics) — Mechanical properties of ceramic composites at room temperature — Determination of compressive properties

1 Scope

This document describes procedures for determination of the compressive behaviour of ceramic matrix composite materials with continuous fibre reinforcement at room temperature. This method applies to all ceramic matrix composites with a continuous fibre reinforcement, uni-directional (1D), bi-directional (2D) and tri-directional (x D, with $2 < x < 3$), tested along one principal axis of reinforcement or off axis conditions. This method also applies to carbon-fibre-reinforced carbon matrix composites (also known as carbon/carbon or C/C). Two cases of testing are distinguished: compression between platens and compression using grips.

2 Normative references

The following documents are referred to in the text in such a way that some or all of their content constitutes requirements of this document. For dated references, only the edition cited applies. For undated references, the latest edition of the referenced document (including any amendments) applies.

ISO 3611, *Geometrical product specifications (GPS) — Dimensional measuring equipment: Micrometers for external measurements — Design and metrological characteristics*

ISO 7500-1, *Metallic materials — Calibration and verification of static uniaxial testing machines — Part 1: Tension/compression testing machines — Calibration and verification of the force-measuring system*

ISO 9513, *Metallic materials — Calibration of extensometer systems used in uniaxial testing*

ISO 14744, *Welding — Acceptance inspection of electron beam welding machines*

ISO 17161, *Fine ceramics (advanced ceramics, advanced technical ceramics) — Ceramic composites — Determination of the degree of misalignment in uniaxial mechanical tests*

3 Terms and definitions

For the purposes of this document, the following terms and definitions apply.

ISO and IEC maintain terminological databases for use in standardization at the following addresses:

— ISO Online browsing platform: available at <https://www.iso.org/obp>

— IEC Electropedia: available at <http://www.electropedia.org/>

3.1

calibrated length

part of the test specimen which has uniform and minimum cross-sectional area

3.2

initial gauge length

L_0

initial distance between reference points on the test specimen in the calibrated length before initiation of the test

3.3
initial cross-sectional area

A_0
initial area of specimen cross section in the calibration length

3.4
longitudinal deformation

ΔL
decrease of the initial gauge length under compressive force

Note 1 to entry: The longitudinal deformation corresponding to the maximum force is denoted as $\Delta L_{c,m}$.

3.5
compressive strain

ε
relative decrease of the gauge length defined as the ratio $\Delta L/L_0$

Note 1 to entry: The compressive strain corresponding to the maximum force is denoted as $\varepsilon_{c,m}$.

3.6
compressive force

F_c
uniaxial force carried by the test specimen at any time during the test
uniaxial compressive force carried by the test specimen at any time during the test

3.7
maximum compressive force

$F_{c,m}$
greatest uniaxial compressive force applied to the test specimen when tested to failure

3.8
compressive stress

σ
compressive force supported by the test specimen at any time in the test divided by the initial cross-sectional area such that $\sigma = F_c/A_0$

iTeh STANDARD PREVIEW
(standards.iteh.ai)
ISO 20504:2019
<https://standards.iteh.ai/catalog/standards/sist/885d2a65-7f90-455c-a49c-a0a1a05c0c2c/iso-20504-2019>

3.9
compressive strength

$S_{c,m}$
greatest compressive stress applied to a test specimen when tested to failure

3.10
proportionality ratio or pseudo-elastic modulus

E_p
slope of the linear region of the stress-strain curve, if any

Note 1 to entry: Examination of the stress-strain curves for ceramic matrix composites allows definition of the following cases:

- Material with a linear region in the stress-strain curve.

For ceramic matrix composites that have a mechanical behaviour characterised by a linear region, the proportionality ratio E_p is defined using Formula (1).

$$E_p(\sigma_1, \sigma_2) = \frac{\sigma_2 - \sigma_1}{\varepsilon_2 - \varepsilon_1} \quad (1)$$

where $(\varepsilon_1, \sigma_1)$ and $(\varepsilon_2, \sigma_2)$ lie near the lower and the upper limits of the linear region of the stress-strain curve (see Annex A, Figures A.1 and A.2).

- Material with nonlinear region in the stress-strain curve. In this case only, stress-strain couples can be determined at specified stresses or specified strains.

3.11 elastic modulus

E

proportionality ratio or pseudo-elastic modulus, in the special case where the linearity starts near the origin

Note 1 to entry: (see [Figure A.2](#)).

4 Principle

A test specimen of specified dimensions is loaded in compression. The compression test is usually performed at a constant cross-head displacement rate or at a constant deformation rate.

Constant force rate is only allowed in the case of linear stress-strain behaviour up to failure.

For crosshead displacement tests, a constant rate is recommended when the test is conducted to failure.

The force and longitudinal deformation are measured and recorded simultaneously.

5 Apparatus

5.1 Test machine

The machine shall be equipped with a system for measuring the force applied to the test specimen that shall conform to grade 1 or better in accordance with ISO 7500-1.

5.2 Load train

The load train is composed of movable and fixed cross-heads, the loading rods and the grips or platens. Load train couplers may additionally be used to connect the grips or platens to the loading rods.

The load train shall align the test specimen axis with the direction of force application without introducing bending or torsion in the test specimen. The misalignment of the test specimen shall be verified and documented in accordance with the procedure described in ISO 17161. The maximum bending shall not exceed 5 % at an average axial strain of 500×10^{-6} .

There are two alternative means of force application.

- 1) Compression platens are connected to the force transducer and the moving cross-head. The parallelism of these platens shall be better than 0,01 mm, in the loading area and the faces of the platens shall be perpendicular to the force application direction.

The use of platens is not recommended for compression testing of 1D and 2D materials with small thicknesses because of buckling.

NOTE A compliant interlayer material (composed only of paper or cardboard) between the test specimen and platens can be used for testing macroscopically inhomogeneous materials to ensure uniform contact pressure.

When the dimensions of the test specimen are such that buckling can occur, it is recommended that antibuckling devices are used similar to those described in ISO 14126. These devices should not introduce parasitic stresses during loading of the test specimen.

- 2) Grips are used to clamp and load the test specimen. The grip design shall prevent the test specimen from slipping and the grips shall align the test specimen axis with that of the applied force.

5.3 Strain measurement

5.3.1 General

For continuous measurement of the longitudinal deformation as a function of the applied force, either strain gauges or a suitable extensometer may be used. Use an extensometer that meets the requirements of at least class 1 in ISO 9513. Measurement of longitudinal deformation over a length as long as possible within the gauge section length of the test specimen is recommended.

5.3.2 Strain gauges

Strain gauges are used for the verification of the alignment on the test specimen. They may also be used to determine longitudinal deformation during testing. In both cases, the length of the strain gauges shall be such that the readings are not affected by local features on the surface of the specimen, such as fibre crossovers. Care shall be taken to ensure that the strain gauge readings are not influenced by the surface preparation and the adhesive used.

5.3.3 Extensometry

5.3.3.1 General

The linearity tolerance of the extensometer shall be less than 0,15 % of the extensometer range used. Extensometers shall meet the requirements of at least class 1 in accordance with ISO 9513.

Types of commonly used extensometers are described in [5.3.3.2](#) and [5.3.3.3](#).

5.3.3.2 Mechanical extensometer

For a mechanical extensometer, the gauge length corresponds to the longitudinal distance between the two locations where the extensometer contacts the test specimen. Mounting of the extensometer to the test specimen shall prevent slippage of the extensometer at the contact points and shall not initiate failure under the contact points. Any extensometer contact forces shall not introduce bending greater than that allowed in [5.2](#).

5.3.3.3 Electro-optical extensometer

Electro-optical measurements of strain require reference marks on the test specimen. For this purpose, fiducial marks such as rods or flags are attached to the test specimen surface perpendicular to the longitudinal axis of the test specimen. The gauge length corresponds to the longitudinal distance between the two fiducial marks.

The use of integral flags as part of the test specimen geometry is not recommended, because of stress concentrations induced by such features.

5.4 Data recording system

A calibrated recorder may be used to record force-deformation curves. The use of a digital data recording system is recommended.

5.5 Dimension-measuring devices

Devices used for measuring linear dimensions of the test specimen shall be accurate to $\pm 0,1$ mm. Micrometers shall be in accordance with ISO 3611.

6 Test specimens

6.1 General

The choice of test specimen geometry depends on several parameters:

- the nature of the material and of the reinforcement structure;
- the type of testing system;
- fibre orientation with respect to loading direction.

The ratio between the length of the test specimen subject to buckling and the thickness of the test specimen, in addition to the stiffness of the material, will influence the resistance of the test specimen to buckling.

If buckling occurs, it can be necessary to modify the dimensions of the test specimen or alternatively to use an antibuckling device (e.g. fixed lateral guides pressed against the test specimen so as to freely allow longitudinal motion while simultaneously suppressing transverse motion).

The volume in the gauge length shall be representative of the material. Volume representative of a minimum of five representative volume elements is recommended.

In the case of off-axis loading conditions, results can depend on the cross-sectional area of specimens due to scale effect. Two types of test specimens can be distinguished.

- a) As-fabricated test specimens, where only the length and the width are machined to the specified size. In this case, two faces of the test specimen can present irregular surfaces.
- b) Machined test specimens, where the length and the width, as well as the two faces of the test specimen, have been machined and present regular machined surfaces.

Tolerance on the thickness dimension only applies to machined test specimens. For as-fabricated test specimens, the difference in thickness out of three measurements (at the centre and at each end of the gauge section length) should not exceed 5 % of the average of the three measurements.

6.2 Compression between platens

The test specimen geometry and/or compliant interlayers may be adapted in order to avoid buckling and damage at the edges due to contact forces.

Type 1 is commonly used and is illustrated in [Figure 1](#). Fixture guides [(3) in [Figure 1](#)] provide lateral support for the specimen while minimizing the contact area. The fixtures (5) are bolted together supporting the specimen (2). The specimen and fixtures are located between a pair of compression platens (4). Recommended dimensions are given in [Table 1](#).

NOTE Other systems are available.

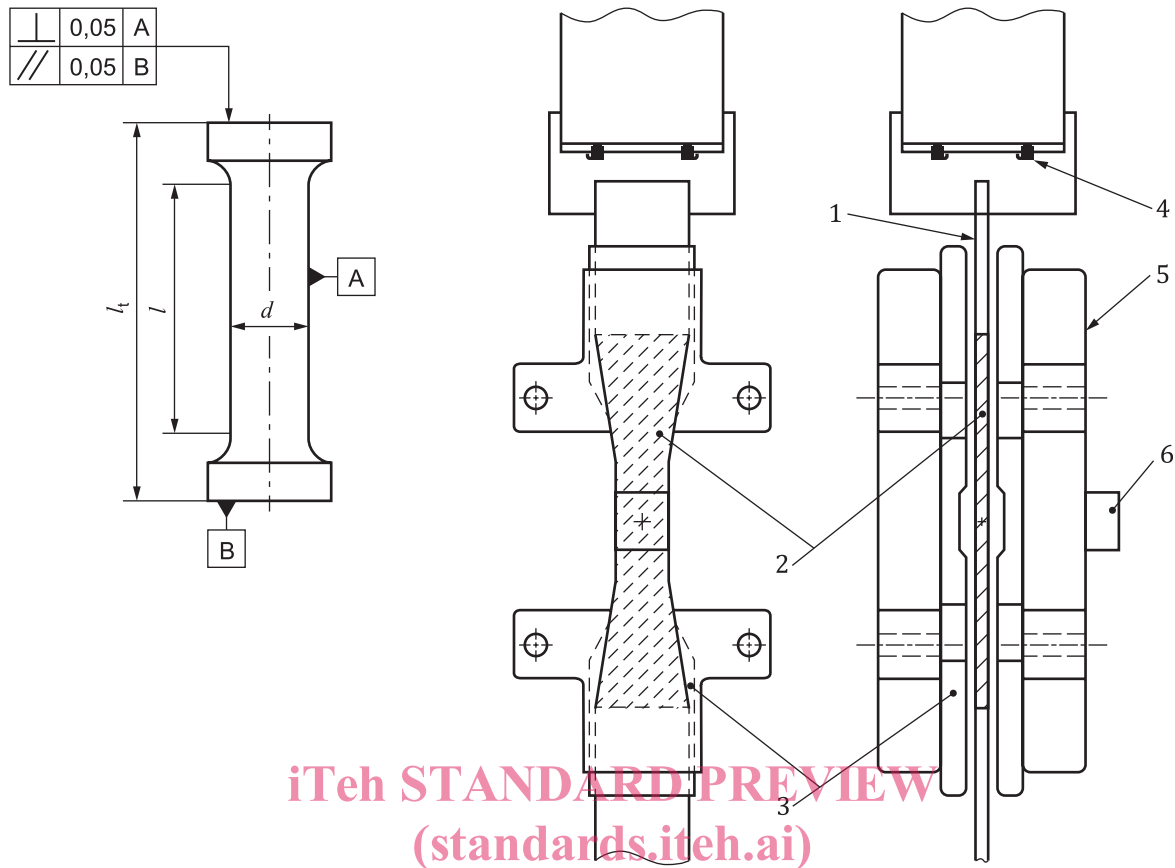

a) Test specimen

b) Example of anti-buckling guides

Key

- 1 loading anvil
- 2 specimen
- 3 lateral support
- 4 O-ring
- 5 frame

ISO 20504:2019
<https://standards.iteh.ai/catalog/standards/sist/885d2a65-7f90-455c-a49c-a0a1a05c0c2c/iso-20504-2019>

- 6 unsupported length
- l calibrated length
- l_t total length
- d cylinder diameter or side length

Figure 1 — Compression test specimen (type 1) used between platens and anti-buckling guides

Table 1 — Dimensions for compression test specimen (type 1) used between platens

Dimensions in millimetres

Parameter	1D, 2D, xD	Tolerance
l , calibrated length	≥ 15	$\pm 0,5$
l_t , total length	$\geq 1,5 \times l$ mm	$\pm 0,5$
d , cylinder diameter or side length	≥ 8	$\pm 0,2$
Parallelism of machined parts	0,05	N/A
Perpendicularity of machined parts	0,05	N/A
Concentricity of machined parts	0,05	N/A
Radius of shoulder	> 10	> 2

Type 2 is cylindrical in shape and is not used as frequently as type 1. It is illustrated in [Figure 2](#) and recommended dimensions are given in [Table 2](#).

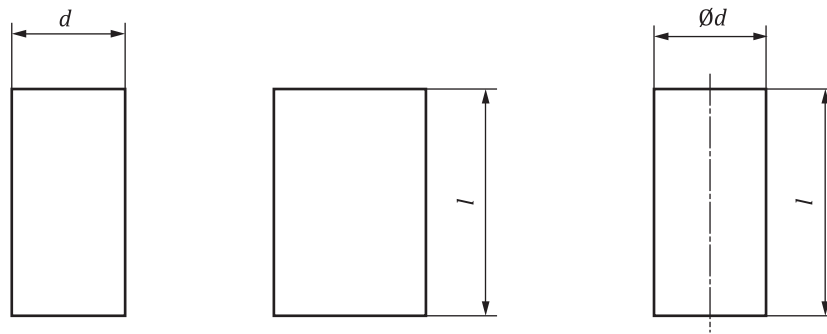

Figure 2 — Compression test specimen (type 2) used between platens

Table 2 — Dimensions for compression test specimen (type 2) used between platens

Dimensions in millimetres

Parameter	1D, 2D, xD	Tolerance
l , calibrated length	≥ 10	$\pm 0,5$
d , cylinder diameter or side length	≥ 10	$\pm 0,2$
Parallelism of machined parts	0,05	N/A
Perpendicularity of machined parts	0,05	N/A

NOTE This test specimen is mainly used when the thickness of the part is not sufficient to machine a test specimen of type 1.

6.3 Test specimen used with grips

For these types of test specimens, the total length l_t depends on the gripping system. These types of test specimens allow testing of thin test specimens without using an anti-buckling device. It is, however, necessary to verify that the chosen l/h ratio does not lead to buckling.

Type 3 is represented in Figure 3 and recommended dimensions are given in Table 3.

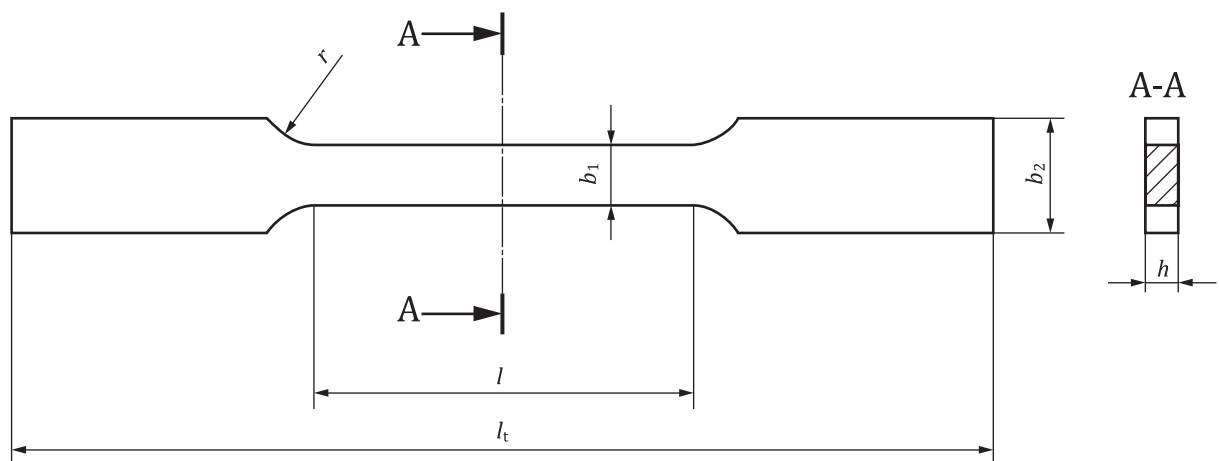

Key

- l_t total test specimen length
- h thickness
- b_1 width in the gauge section length
- b_2 width
- r radius of shoulder

Figure 3 — Compression test specimen (type 3) for use with grips