

---

---

**Dentistry — Endodontic obturating  
materials**

*Médecine bucco-dentaire — Matériaux d'obturation endodontique*

**iTeh STANDARD PREVIEW**  
**(standards.iteh.ai)**

[ISO 6877:2021](https://standards.iteh.ai/catalog/standards/sist/135393e2-39e5-4e7b-8a78-0e692a3ba720/iso-6877-2021)

<https://standards.iteh.ai/catalog/standards/sist/135393e2-39e5-4e7b-8a78-0e692a3ba720/iso-6877-2021>



**iTeh STANDARD PREVIEW**  
**(standards.iteh.ai)**

ISO 6877:2021

<https://standards.iteh.ai/catalog/standards/sist/135393e2-39e5-4e7b-8a78-0e692a3ba720/iso-6877-2021>



**COPYRIGHT PROTECTED DOCUMENT**

© ISO 2021

All rights reserved. Unless otherwise specified, or required in the context of its implementation, no part of this publication may be reproduced or utilized otherwise in any form or by any means, electronic or mechanical, including photocopying, or posting on the internet or an intranet, without prior written permission. Permission can be requested from either ISO at the address below or ISO's member body in the country of the requester.

ISO copyright office  
CP 401 • Ch. de Blandonnet 8  
CH-1214 Vernier, Geneva  
Phone: +41 22 749 01 11  
Email: [copyright@iso.org](mailto:copyright@iso.org)  
Website: [www.iso.org](http://www.iso.org)

Published in Switzerland

# Contents

Page

<b>Foreword</b> .....	<b>iv</b>
<b>Introduction</b> .....	<b>v</b>
<b>1 Scope</b> .....	<b>1</b>
<b>2 Normative references</b> .....	<b>1</b>
<b>3 Terms and definitions</b> .....	<b>1</b>
<b>4 Requirements</b> .....	<b>3</b>
4.1 Appearance.....	3
4.2 Length.....	3
4.3 Size designation and taper.....	3
4.3.1 General.....	3
4.3.2 Standard points.....	3
4.3.3 Greater taper points.....	5
4.3.4 Variable taper points.....	5
4.3.5 Auxiliary points.....	5
4.3.6 Carrier-based obturating material.....	5
4.4 Physical integrity.....	6
4.5 Radiopacity.....	6
4.6 Colour-coding.....	6
<b>5 Procurement of samples</b> .....	<b>7</b>
<b>6 Measurement and test methods</b> .....	<b>7</b>
6.1 Test conditions.....	7
6.2 Visual examination.....	7
6.2.1 General.....	7
6.2.2 Labels.....	7
6.2.3 Instructions for use.....	8
6.3 Length.....	8
6.3.1 Apparatus.....	8
6.3.2 Method.....	8
6.4 Size designation.....	8
6.4.1 Apparatus.....	8
6.4.2 Method.....	8
6.4.3 Taper.....	9
6.5 Physical integrity.....	9
6.5.1 General.....	9
6.5.2 Apparatus.....	9
6.5.3 Method.....	9
6.5.4 Interpretation of the results.....	10
6.6 Radiopacity for polymeric points and carrier-based obturating devices.....	11
6.6.1 Apparatus.....	11
6.6.2 Procedure.....	11
6.6.3 Interpretation of the results.....	11
6.7 Melt mass flow rate.....	11
<b>7 Packaging, marking and instructions and information to be supplied by the manufacturer</b> .....	<b>12</b>
7.1 Packaging.....	12
7.2 Labelling.....	12
7.3 Declaration of components.....	13
<b>Annex A (normative) Melt mass-flow rate test</b> .....	<b>14</b>
<b>Bibliography</b> .....	<b>17</b>

## Foreword

ISO (the International Organization for Standardization) is a worldwide federation of national standards bodies (ISO member bodies). The work of preparing International Standards is normally carried out through ISO technical committees. Each member body interested in a subject for which a technical committee has been established has the right to be represented on that committee. International organizations, governmental and non-governmental, in liaison with ISO, also take part in the work. ISO collaborates closely with the International Electrotechnical Commission (IEC) on all matters of electrotechnical standardization.

The procedures used to develop this document and those intended for its further maintenance are described in the ISO/IEC Directives, Part 1. In particular the different approval criteria needed for the different types of ISO documents should be noted. This document was drafted in accordance with the editorial rules of the ISO/IEC Directives, Part 2 (see [www.iso.org/directives](http://www.iso.org/directives)).

Attention is drawn to the possibility that some of the elements of this document may be the subject of patent rights. ISO shall not be held responsible for identifying any or all such patent rights. Details of any patent rights identified during the development of the document will be in the Introduction and/or on the ISO list of patent declarations received (see [www.iso.org/patents](http://www.iso.org/patents)).

Any trade name used in this document is information given for the convenience of users and does not constitute an endorsement.

For an explanation of the voluntary nature of standards, the meaning of ISO specific terms and expressions related to conformity assessment, as well as information about ISO's adherence to the World Trade Organization (WTO) principles in the Technical Barriers to Trade (TBT) see the following URL: [www.iso.org/iso/foreword.html](http://www.iso.org/iso/foreword.html). (standards.iteh.ai)

This document was prepared by Technical Committee ISO/TC 106, *Dentistry*, Subcommittee SC 1, *Filling and Restorative Materials*, in collaboration with the European Committee for Standardization (CEN) Technical Committee CEN/TC 55, *Dentistry*, in accordance with the Agreement on technical cooperation between ISO and CEN (Vienna Agreement).

This third edition cancels and replaces the second edition (ISO 6877:2006), which has been technically revised.

The main changes compared to the previous edition are as follows:

- use of “endodontic” rather than “root canal” for the terminology;
- inclusion of points having a non-uniform taper;
- inclusion of thermoplastic materials not in the form of a point;
- standardization to the use of  $D$ ,  $d_3$  and  $d_{16}$  for measurements of endodontic points at the projection of the tip, 3 mm or 16 mm from the tip of a point;
- harmonization of  $D$ ,  $d_3$  and  $d_{16}$  with the ISO 3630 series;
- reconsidering tests methods;
- addition of ISO 13116 for test method for determining radiopacity of material as a normative reference;
- augmenting the packaging requirements for providing information;
- addition of an annex for measuring the melt-flow rate of thermoplastic materials that are not supplied in point form.

Any feedback or questions on this document should be directed to the user's national standards body. A complete listing of these bodies can be found at [www.iso.org/members.html](http://www.iso.org/members.html).

## Introduction

The following information should be taken into account when using this document: specific qualitative and quantitative test methods for demonstrating freedom from unacceptable biological risks are not included in this document but it is recommended that, for the assessment of such biological risks, reference be made to ISO 7405 and ISO 10993-1. No performance limits are provided in this document for melt mass flow rate, but they might be added in the future.

## iTeh STANDARD PREVIEW (standards.iteh.ai)

[ISO 6877:2021](https://standards.iteh.ai/catalog/standards/sist/135393e2-39e5-4e7b-8a78-0e692a3ba720/iso-6877-2021)

<https://standards.iteh.ai/catalog/standards/sist/135393e2-39e5-4e7b-8a78-0e692a3ba720/iso-6877-2021>

**iTeh STANDARD PREVIEW**  
**(standards.iteh.ai)**

ISO 6877:2021

<https://standards.iteh.ai/catalog/standards/sist/135393e2-39e5-4e7b-8a78-0e692a3ba720/iso-6877-2021>

# Dentistry — Endodontic obturating materials

## 1 Scope

This document establishes the specifications for the dimensions of various endodontic obturating materials including preformed metal, preformed polymeric-coated metal, polymeric points, thermoplastic obturating material or combinations of the above, suitable for use in the obturation of the root canal system. This document also specifies numerical systems and a colour-coding system for designating the sizes of preformed endodontic obturating points.

Dental endodontic obturating points are marketed sterilized or non-sterilized. This document covers the physical attributes expected of such products as supplied.

Sterility is not included in this document, and any claim that the product is sterile is the responsibility of the manufacturer (see [Table 3](#)). [Clause 7](#) specifies the labelling needed, including the instructions for use.

This document does not apply to instruments or apparatus used in conjunction with thermoplastic obturating materials (obturator material that deform with heat). This document is not applicable to materials for support of a coronal restoration.

## 2 Normative references

The following documents are referred to in the text in such a way that some or all of their content constitutes requirements of this document. For dated references, only the edition cited applies. For undated references, the latest edition of the referenced document (including any amendments) applies.

ISO 1942, *Dentistry — Vocabulary*

ISO 3630-1, *Dentistry — Endodontic instruments — Part 1: General requirements*

ISO 13116, *Dentistry — Test method for determining radio-opacity of materials*

ISO 15223-1, *Medical devices — Symbols to be used with information to be supplied by the manufacturer — Part 1: General requirements*

## 3 Terms and definitions

For the purposes of this document, the terms and definitions given in ISO 1942, ISO 3630-1 and the following apply.

ISO and IEC maintain terminological databases for use in standardization at the following addresses:

- ISO Online browsing platform: available at <https://www.iso.org/obp>
- IEC Electropedia: available at <http://www.electropedia.org>

### 3.1

#### **endodontic obturating material**

substance intended as a definitive product to fill a prepared root canal system, usually a combination of *points* ([3.2](#)) and *endodontic sealer* ([3.15](#))

**3.2  
point**

preformed metal, preformed polymeric-coated metal, and polymeric cones for use in the obturation of a root canal system

Note 1 to entry: For the purposes of this document, the term “endodontic obturating point (cone)” is abbreviated as “point”.

**3.3  
size designation**

numerical indication, “000”, of the projected tip diameter, measured in hundredths of a millimetre

**3.4  
taper**

percentage increase in diameter along the length of the *point* (3.2)

EXAMPLE 02 taper represents a 2 % increase in diameter along the length of the point.

**3.5  
standard point**

*point* (3.2) having a uniform 02 taper over the first 16 mm

**3.6  
greater taper point**

*point* (3.2) having a uniform taper greater than 02 over the first 16 mm

**3.7  
variable taper point**

*point* (3.2) which has a taper that varies over the first 16 mm

**3.8  
auxiliary point**

*point* (3.2) excepting *standard point* (3.5), *greater taper point* (3.6) and *variable taper point* (3.7)

**3.9  
carrier-based obturating device**

*point* (3.2) designed to obturate a root canal with thermoplastic polymeric material coated on a core material, usually in the shape of a *point* (3.2)

Note 1 to entry: The core material remains in the canal or may be removed after carrying the thermoplastic material.

**3.10  
injection material**

substance supplied in non-conical form, such as pellets for injection after being warmed to a thermoplastic state

**3.11  
injection system**

instrument designed to obturate a root canal with thermoplasticized *injection material* (3.9) using an injection equipment or device

**3.12  
melt mass-flow rate**

**MFR**

measure of flow through a capillary of a thermoplastic polymer at a particular temperature, measured in grams per unit time at a given force

**3.13  
unit pack**

smallest pack of points distributed, containing one or more sizes of *points* (3.2)

iTeh STANDARD PREVIEW  
(standards.iteh.ai)

ISO 6877:2021

<https://standards.iteh.ai/catalog/standards/sist/135393e2-39e5-4e7b-8a78-0c092a30a720/iso-6877-2021>



**3.14****radiopacity**

property of obstructing the passage of radiant energy, such as x-rays, through the representative areas appearing grey or white on the exposed film or sensor image

**3.15****endodontic sealer**

material intended to permanently seal the root canal dentine from the periapical tissue usually in combination with a solid or semi-solid core material [*endodontic obturating material* (3.1)], to fill voids and to seal root canals during orthograde obturation

**4 Requirements****4.1 Appearance**

Throughout the tapered length, the point shall be smooth and uniform in appearance, free from extraneous matter. Test according to 6.2.

**4.2 Length**

Unless otherwise stated by the manufacturer, the overall length shall be not less than 28 mm. Test according to 6.3.

**4.3 Size designation and taper****4.3.1 General**

The designation shall be in the form of a five-digit numerical set, having two parts: 000 XX, where 000 corresponds to the size designation and XX corresponds to the two significant figures of the taper per cent. For example, a 2 % taper is designated as 02.

The diameter tolerance of points at  $d_{16}$  (see Figure 1) shall be:

- $\pm 0,02$  mm for metallic points (cones),
- $\pm 0,05$  mm for polymeric points or carrier-based obturating devices of sizes 008 to 025,
- $\pm 0,07$  mm for polymeric points of carrier-based obturating devices of sizes 030 to 140.

The tolerances of 0,05 and 0,07 are not applicable to  $D$ .

**4.3.2 Standard points**

- a) The taper of the points shall be uniform for a minimum of 16 mm from the tip (see Figure 1), increasing at 2 % (02) along their length.
- b) The size designation of standard polymer points or carrier-based obturating devices shall be in accordance with the numbering system shown in Table 1.

Test according to 6.4.2, and calculate the taper as described in 6.4.3.

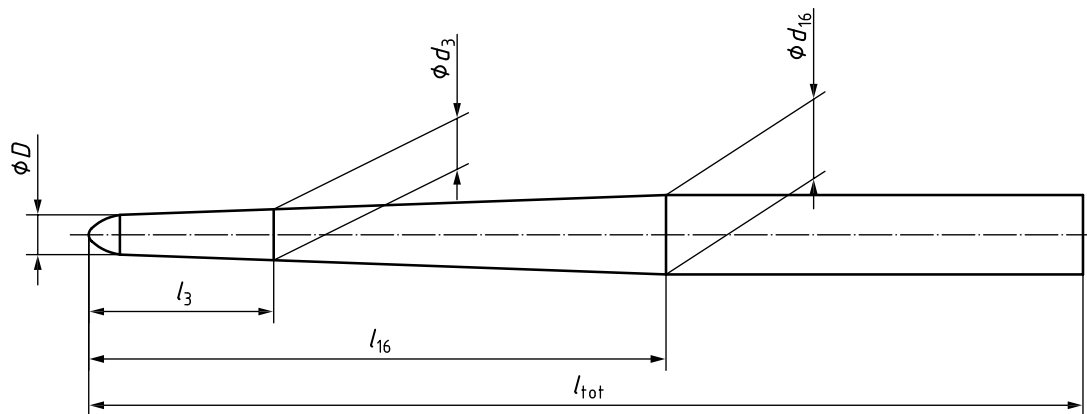

**Key**

- $D$  diameter of the projection of the point at the tip
- $d_3$  diameter at 3 mm from tip
- $d_{16}$  diameter at 16 mm from tip
- $l_{tot}$  total length of the instrument

NOTE 1 The diameters  $D$ ,  $d_3$  and  $d_{16}$  are expressed in millimetres

NOTE 2 [Table 1](#) gives values of  $D$ ,  $d_3$  and  $d_{16}$  for each size of standard points, not carrier-based obturation devices.

NOTE 3 The exact shape of the tip is left to the option of the manufacturer.

**Figure 1 — Diagrammatic representation of a point**

ISO 6877:2021  
<https://standards.iteh.ai/catalog/standards/sist/135393e2-39e5-4e7b-8a78-0c692a50a720/iso-6877-2021>  
**Table 1 — Size designation for standard points**

Dimensions in millimetres

Size designation	$D$	$d_3$	$d_{16}$
008	0,08	0,14	0,40
010	0,10	0,16	0,42
015	0,15	0,21	0,47
020	0,20	0,26	0,52
025	0,25	0,31	0,57
030	0,30	0,36	0,62
035	0,35	0,41	0,67
040	0,40	0,46	0,72
045	0,45	0,51	0,77
050	0,50	0,56	0,82
055	0,55	0,61	0,87
060	0,60	0,66	0,92
070	0,70	0,76	1,02
080	0,80	0,86	1,12
090	0,90	0,96	1,22
100	1,00	1,06	1,32

NOTE The tolerances of 0,05 and 0,07 from [4.3.1](#) are not applicable to  $D$ .

Table 1 (continued)

Size designation	$D$	$d_3$	$d_{16}$
110	1,10	1,16	1,42
120	1,20	1,26	1,52
130	1,30	1,36	1,62
140	1,40	1,46	1,72

NOTE The tolerances of 0,05 and 0,07 from [4.3.1](#) are not applicable to  $D$ .

#### 4.3.3 Greater taper points

- The size designation of greater taper polymer points or carrier-based obturating devices shall be in accordance with the numbering system shown in [Table 1](#).
- The taper of the points shall be uniform for a minimum of 16 mm from the tip ([Figure 1](#)), increasing along their length at the taper given by the manufacturer.

Test according to [6.4.2](#), and calculate the taper as described in [6.4.3](#).

#### 4.3.4 Variable taper points

The tip diameter and the taper type of the variable taper points shall be designated as variable by the manufacturer ([Table 2](#)).

The tolerances of  $\pm 0,05$  and  $\pm 0,07$  are not applicable to  $D$ .

The colour of variable taper points should be that colour corresponding to the tip size in [Table 2](#).

Test according to [6.4.2](#).

#### 4.3.5 Auxiliary points

The taper of the auxiliary points is from 02 to 09 (2 % to 9 %).

The tip size of the auxiliary points is left to the discretion of the manufacturer.

The colour of auxiliary points should be that colour corresponding to the tip size in [Table 2](#).

#### 4.3.6 Carrier-based obturating material

[Figure 2](#) shows the features of a carrier-based obturating device. If standard, these points shall conform to the dimensional requirements of [Table 1](#).

If variable, the taper of the points is variable over the first 16 mm. The tip diameter and the taper type of the points shall be designated as variable by the manufacturer (see [Table 3](#)).