



~~Designation: F 1169-03~~ Designation: F1169 – 09

Standard Specification for Full-Size Baby Crib¹

This standard is issued under the fixed designation F1169; the number immediately following the designation indicates the year of original adoption or, in the case of revision, the year of last revision. A number in parentheses indicates the year of last reapproval. A superscript epsilon (ϵ) indicates an editorial change since the last revision or reapproval.

INTRODUCTION

This consumer safety specification addresses crib accidents that were identified by the U.S. Consumer Product Safety Commission (CPSC).

CPSC received reports of strangulations incidents associated with crib corner post extensions and incidents concerning failure of crib hardware and other structural components of cribs that also resulted in fatalities

In response to the accident data collected by the CPSC, this consumer safety specification attempts to minimize the risk of injury or death due to: failure of mattress support hardware, failure of glued or bolted connections, ~~dropside~~ latch failure, and dislodgment of teething rails. This safety specification also addresses incidents associated with poor maintenance or assembly by means of requirements for the contents of instructional literature that must accompany a crib.

1. Scope

1.1 This consumer safety specification establishes performance requirements and test procedures to determine the structural integrity of cribs. It also contains design requirements addressing entanglement on crib corner post extensions, and requirements for warning labels and instructional material.

1.2 No crib produced after the approval date of this consumer safety specification shall, either by label or other means, indicate compliance with this specification unless it conforms to all requirements contained herein.

~~1.3~~

1.3 The values stated in inch-pound units are to be regarded as standard. The values given in parentheses are mathematical conversions to SI units that are provided for information only and are not considered standard.

1.4 The following safety hazards caveat pertains only to the test methods portion, Section 7, of this specification: This standard does not purport to address all of the safety concerns, if any, associated with its use. It is the responsibility of the user of this standard to establish appropriate safety and health practices and determine the applicability of regulatory limitations prior to use.

2. Referenced Document ~~Referenced Documents~~

~~2.1 Federal Standard: Federal Standards:~~²

16 CFR 1303 Ban of Lead-Containing Paint and Certain Consumer Products Bearing Lead-Containing Paint

16 CFR 1500.50–.52 Test Methods for Simulating Use and Abuse of Toys and Other Articles Intended for Use by Children

16 CFR 1501 Method for Identifying Toys and Other Articles Intended for Use by Children Under Three Years of Age Which Present Choking, Aspiration or Ingestion Hazards Because of Small Parts

~~16 CFR 1508 Requirements for Full-Size Baby Cribs~~ 16 CFR 1508 Requirements for Full-Size Baby Cribs

~~2.2 European Standard:~~³

EN 716 Furniture - Children's cots and folding cots for domestic use

3. Terminology

~~3.1 drop side/drop gate, n—a side that is intended to slide with respect to the frame when the product is in the manufacturer's recommended use position to provide easier access to the occupant.~~

~~3.2 dynamic load, n—application of an impulsive force by a free falling mass.~~

¹ This specification is under the jurisdiction of ASTM Committee F15 on Consumer Products and is the direct responsibility of Subcommittee F15.18 ~~45.18~~ on Cribs, Toddler Beds, Play Yards, Bassinets, ~~Cradles~~, Cradles and Changing Tables.

Current edition approved Aug. 10, 2003; Nov. 15, 2009. Published Aug. 2003-December 2009. Originally approved in 1988. Last previous edition approved in 1999 ~~2007~~ as F1169 – 07. DOI: 10.1520/F1169-09.

² Available from the Consumer Product Safety Commission, Washington, DC 20207.

³ Available from European Committee for Standardization (CEN), 36 rue de Stassart, B-1050, Brussels, Belgium, <http://www.cenorm.be>.

3.3

3.2 *folding side, n*—a side, or a part thereof, that is intended to fold with respect to the frame when the product is in the manufacturer’s recommended use position to provide easier access to the occupant.

3.4

3.3 *full-size crib, n*—a bed that is designed to provide sleeping accommodations for an infant having interior dimensions of $28 \pm \frac{5}{8}$ in. (710 \pm 16 mm) wide and $52\frac{3}{8} \pm \frac{5}{8}$ in. (1330 \pm 16 mm) long.

3.4 *moveable side, n*—top portion of an otherwise stationary side that is intended to move with respect to the frame (other than a folding side) when the product is in the manufacturer’s recommended use position to provide easier access to the occupant.

3.5 *occupant, n*—that individual who is in the product when it is setup in one of the manufacturer’s use positions.

3.6 *static load, n*—~~a vertically downward force applied by a calibrated force gage or by dead weights.~~ force applied by a calibrated force gauge or by dead weights.

3.7 *stationary side, n*—a side or end panel that is not intended to fold, slide or move with respect to the frame when the product is in the manufacturer’s recommended use position.

3.8 *structural failure, n*—damage to a component(s) or assembly resulting in partial separation (greater than 0.040 in. (1.00 mm) over original configuration), or complete separation of the component(s) or assembly.

4. Calibration and Standardization

4.1 All testing shall be conducted on a concrete floor which may be covered with 1/8-in. (3-mm) thick vinyl floor covering.

4.2 The crib shall be completely assembled, unless otherwise noted, in accordance with the manufacturer’s instructions.

4.3 No testing shall be conducted within 48 h of gluing.

4.4 The item to be tested shall be in a room with ambient temperature of $73.4 \pm 9^\circ\text{F}$ ($23 \pm 5^\circ\text{C}$) for at least 24 h prior to testing. Testing shall then be conducted within this temperature range.

5. General Requirements

5.1 Before performing any of the tests in this specification all wood parts shall be smooth and free of splinters.

5.2 *Surface Coatings*—The paint or surface coating on the product shall comply with 16 CFR 1303.

5.3 *Small Parts*—There shall be no small parts as defined by 16 CFR 1501 before testing or liberated as a result of testing to this specification.

5.4 *Corner Posts:*

5.4.1 No corner post assembly shall extend more than 0.06 in. (1.50 mm) above the upper edge of an end or side panel, whichever is higher, when measured from the lowest point on the upper edge of the end or side panel within 3 in. (76 mm) from the outermost contour of the post or elbow (see Fig. 1).

5.4.1.1 This requirement applies when any ~~drop side/drop gate~~ moveable side/folding side is in either the raised or lowered position.

5.4.2 The limitations in 5.4.1 do not apply to a corner post assembly that extends at least 16 in. (400 mm) above the uppermost surface of the side rail in its highest position.

5.4.3 Corner posts intended to accept removable vertical extensions made up of two or more segments (such as canopy post extensions) shall not permit the attachment of individual segments such that the resultant vertical extension would be in violation of the dimensional requirements of 5.4.

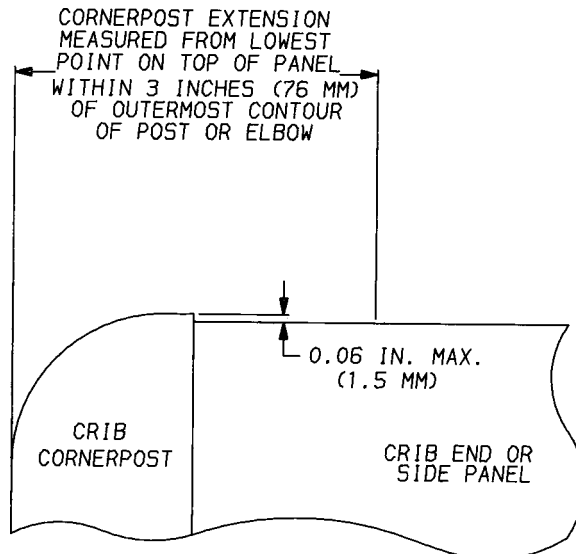

FIG. 1 Illustration of Requirements for Crib Corner Post Extensions

5.5 Slat Construction—Slats shall not contain any lateral/transverse joints such as finger-joints, and other means of joining pieces of lumber end-to-end are not permitted.

5.6 Crib Side Configurations:

5.6.1 Cribs with side(s) having movable components intended to aid in access to the occupant shall have those sides rigidly attached to the crib ends and contain no movable section more than 6 in. (15 cm) below the top of the side top rail in its fully raised position. Horizontal rails located more than 26 in. (66 cm) above the top surface of the mattress support in its lowest adjustable position shall not be considered toeholds.

5.6.2 Cribs with only stationary sides shall meet the following criteria: The height of the uppermost surface of any top horizontal rail shall be at least 15 in. (38 cm) above the top surface of the mattress support in its highest adjustable position.

6. Performance Requirements

6.1 Mattress Support System Vertical Impact Test Requirements:

6.1.1 After testing in accordance with the procedure in Spindle/Slat Strength Testing—After testing in accordance with the procedure in 7.1, the crib shall comply with 16 CFR Part 1508. Components attached by screws shall not have separated by more than 0.04 in. (1.00 mm) upon completion of testing, there shall be no slat breakage or complete separation of a slat from the side rails or the crib end main horizontal members.

6.2 Mattress Support System Vertical Impact Test Requirements—After testing in accordance with the procedure in 7.2, the crib shall comply with 16 CFR 1508. Components attached by screws shall not have separated by more than 0.04 in. (1.00 mm) upon completion of testing.

6.3 Crib Side Test Requirements :

6.2.1 After completion of the cyclic and static portions of either the drop-side or stationary side test as appropriate, tests, the crib shall comply with 16 CFR Part 1508 and no spindles or slats shall have broken or completely separated from the top or bottom rail. Complete separation shall be determined by placing a right triangular prism shaped wedge (see Fig. 1 in 16 CFR Part 1508) between two spindles or slats adjacent to the rail from which these have separated and applying a 20-lbf (90-N) pull force to the wedge in a direction normal to the plane of the crib side. If a spindle or slat moves away from the hole in the rail in which it was formerly secured, complete separation has occurred.

6.2.2 Components attached by screws shall not have separated by more than 0.04 in. (1 mm) upon completion of testing.

6.2.3 Any spindles or slats that could be rotated during the torque test shall comply with the spacing of crib components at 16 CFR Section 1508.4 when turned to their most adverse position.

6.2.4 Breakage of a wooden crib side component in any location other than a joint during testing does not constitute a failure. However, if this type of breakage should occur, an additional side must be tested.

Note 1—A wood failure within a joint does constitute a test failure.

6.3

6.3.2 Components attached by screws shall not have separated by more than 0.04 in. (1 mm) upon completion of testing.

6.3.3 Any spindles or slats that could be rotated during the torque test shall comply with the spacing of crib components at 16 CFR 1508.4 when turned to their most adverse position.

6.4 Mattress Support System Test Requirement:

6.3.1 When tested in accordance with the procedure in 7.3.7.4, the mattress support system shall not detach from the crib at any point of attachment, or the force applied in 7.3.3.6-7.4.3.6 cannot be maintained for 10 s.

6.4

6.5 Crib Side Latch Test Requirements:

6.4.1 The 6.5.1 The latching mechanism securing a drop/moveable or folding side of a crib shall automatically engage when the side is placed in the normal use position.

6.4.2 The 6.5.2 The latching mechanism shall not disengage during the tests conducted in accordance with the procedure in 7.4.4.7.5.4 or 7.4.5-7.5.5 (whichever is appropriate), and shall continue to function in the intended manner upon completion of the tests.

6.5

6.6 Plastic Teething Rail Test Requirement—The feeler gage specified in 7.5.2.1-7.6.2.1 shall not enter any gap created by the deflection or deformation, or both, of the plastic teething rail resulting from the application of a 50-lbf (222-N) vertically downward force.

7. Test Methods

7.1

7.1 Spindle/Slat Static Load Strength:

7.1.1 Spindle/slat static load test may be performed either with the crib assembled according to manufacturer’s instructions with the mattress support in its lowest adjustable position, with casters removed and with the crib rigidly constrained or with the spindle/slat assemblies removed from the crib and rigidly supported at the upper and lower horizontal rails in manner that shall not interfere with a spindle/slat defecting under the applied force.

7.1.2 Gradually, over a period of not less than 2 s nor greater than 5 s, apply a 56.2-lb weight or force (25.5 kg or 250 N) at the midpoint, between the top and bottom of the spindle/slat being tested. This weight or force shall be applied through a contact area large enough to not cause visible indentation or cutting of the spindle/slat, but not wider than 1 in. (2.54 cm) when measured parallel to the longitudinal axis of the spindle/slat. This weight shall be maintained for 30 s.

7.1.3 Test a minimum of 25 % of all slats. Test at least two slats of any differing dimension, if available.

7.1.4 End vertical rails that are joined between the slat assembly top and bottom rails are not considered slats and do not require testing to this procedure.

7.2 *Mattress Support System Vertical Impact Test*

7.2.1:

7.2.1 *General*—This test consists of dropping a specified weight repeatedly onto a foam pad supported by the crib mattress support system. The test assists in evaluating the structural integrity of the crib assembly. Glue joints and other means of fastening are subjected to abusive loads and stresses.

7.2.2

7.2.2 *Apparatus for Vertical Impact Testing:*

7.2.2.1 *Test frame* (see

7.2.2.1 Test frame (see Fig. 2).

7.2.2.2 A weight used in conducting this test shall have a flat circular contact area of 1 ft² (930 cm²) (13.5-in. (343-mm) diameter) with a 0.125-in. (3-mm) radius to ease the edge between the circular contact surface and the vertical cylindrical surface.

7.2.2.3 The total weight shall be 45 lb (20.4 kg).

7.2.2.4 The weight shall pivot freely.

7.2.2.5 A 4-in. (100-mm) thick open cell polyurethane foam pad having a density of 1 lb/ft³ (16 kg/m³) covered with a 5 to 15 gage vinyl material (tick) shall be used to represent a mattress.

7.2.3

7.2.3 *Procedure for Vertical Impact Testing of Full-Size Cribs:*

7.2.3.1 Casters shall not be installed on the crib (see

7.2.3.1 The crib is to be assembled in accordance with the manufacturer's instructions except that casters shall not be installed on the crib (see Fig. 3).

7.2.3.2 The crib shall be prevented from sliding in a manner that does not prevent changes of angle that may take place in the crib structure (see Fig. 3).

7.2.3.3 All testing shall be conducted with the mattress support in the lowest position.

7.2.3.4 Allow the weight to free fall 6 in. (150 mm) on to the upper surface of the foam pad at a rate of 4 ± 1 s/cycle for the following number of cycles:

7.2.3.5 500 cycles within ¼ in. (6.4 mm) of the geometric center of the mattress area.

7.2.3.6 100 cycles at each of two diagonally opposite corners, centered 9 in. (230 mm) from the crib sides forming the corner.

7.2.3 *Crib Side Test:* <https://standards.iteh.ai/catalog/standards/sist/4f13f99a-9d5c-4912-9d97-f1f3fd1de617/astm-f1169-09>

7.2.4

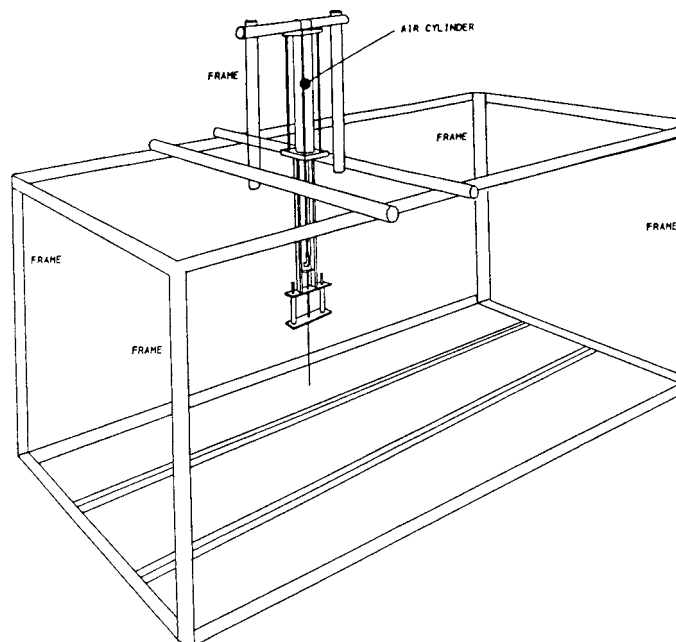

FIG. 2 Typical Test Frame

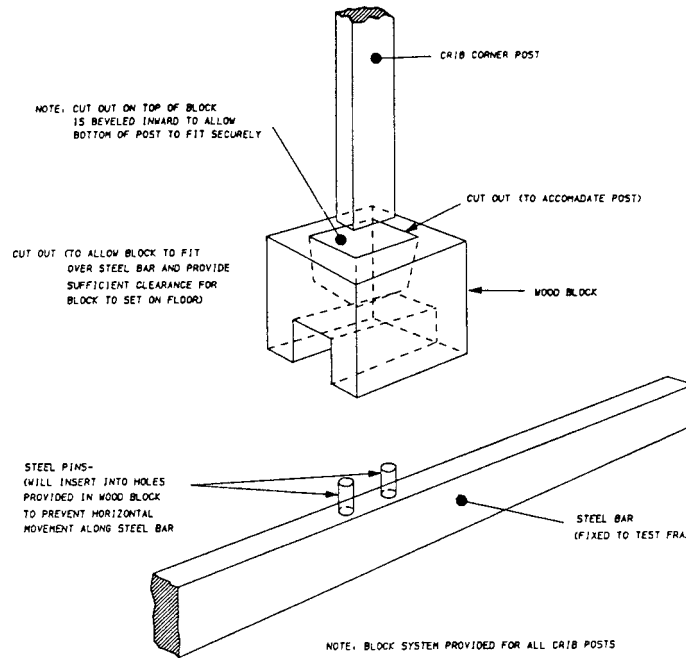

FIG. 3 Typical Crib Corner Post Positioning Block

7.3.1 General—This test consists of repeatedly impacting a crib side bottom rail by a specified weight. After completing the cyclic testing, structural integrity is tested by applying a static pull to the side assembly followed by a torque test of each spindle or slat.

7.2.2.3.2 Apparatus for Crib Side Cyclic Test—The apparatus for the cyclic test (see Fig. 4) includes the following:

7.2.2.1A 30-lb (13.6-kg) weight.

7.2.2.2A 0.375-in. (9-mm) thick 30 Type A durometer rubber pad large enough to cover the impact area.

7.2.2.3 Three support trough (see Fig. 5) for drop side test only.

Note—For tests of metal cribs, an additional support trough may be used to support the center of the top rail if necessary to avoid deformation.

7.2.2.4 Two vertical stops (see Fig. 6) for drop side only.

7.2.2.5 Impactor with a width of 1 in. (25 mm) and sufficient length to extend across the full width of the bottom rail.

7.2.3

7.3.2.1 A 30-lb (13.6-kg) weight.

7.3.2.2 A 0.375-in. (9-mm) thick 30 Type A durometer rubber pad large enough to cover the impact area.

7.3.2.3 Impactor with a width of 1 in. (25 mm) and sufficient length to extend across the full width of the bottom rail.

7.3.3 Apparatus for Crib Side Static Test:

7.2.3.1A 100-lb (45.4-kg) weight.

7.2.3.2A rigid frame (see Fig. 7) for drop side only.

7.2.4 Procedure for Drop Side Cyclic Test

7.3.3.1 A 100-lb (45.4-kg) weight.

7.3.4 Crib Side Cyclic Tests:

7.2.4.1 Remove the side from the crib assembly.

7.2.4.2 Mount the side in a rigid test fixture so that it will hang vertically as it would when assembled to a crib.

7.2.4.3 Support the side within 2 in. (50 mm) of each end of the top rail by placing the top rail in a trough-like support fixture (see Fig. 5).

7.2.4.4 To prevent "pendulum swing" of the side during testing, the side bottom rail may be loosely constrained between two vertical stops (see Fig. 6).

7.2.4.5 Allow the 30-lb (13.6-kg) weight to free-fall 3 in. (76 mm) 250 times at a rate of 4 ± 1 s/cycle such that it impacts directly upon the 0.375-in. (9-mm) thick rubber pad located on the top surface of the bottom rail between two adjacent spindles or slats as near the center of the rail as possible.

7.2.5 Drop Side Static Test

7.3.4.1 The crib is to be assembled in accordance with the manufacturer's instructions except that casters shall not be installed on the crib.

7.3.4.2 Secure the bottom ends of the crib to eliminate horizontal motion at the base.

7.3.4.3 Allow the 30-lb (13.6-kg) weight to free-fall 3 in. (76 mm) 250 times at a rate of 4 ± 1 s/cycle such that it impacts directly upon the 0.375-in. (9-mm) thick rubber pad located on the top surface of the bottom rail between two adjacent spindles

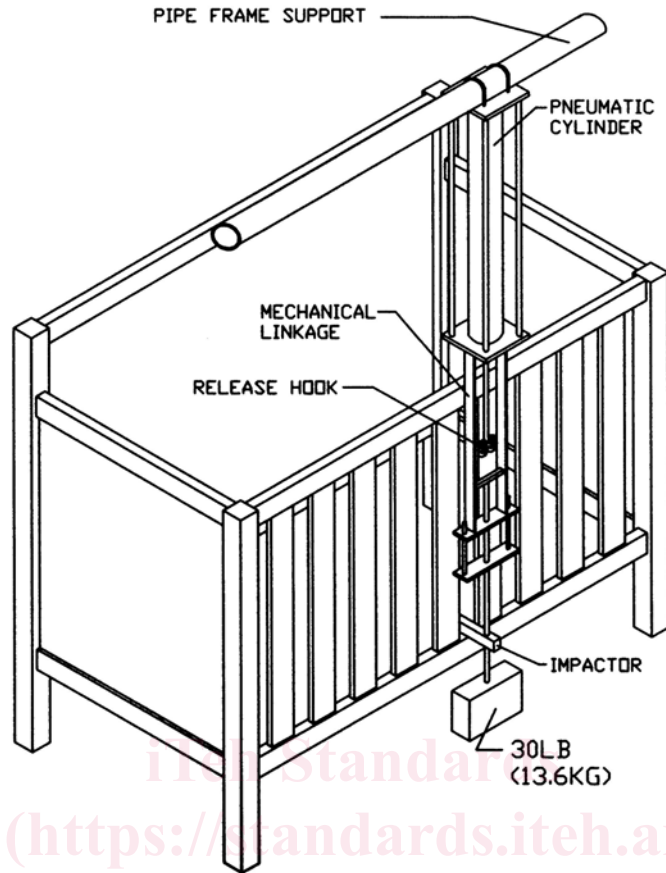

FIG. 4 Typical Side Assembly Test Fixture

or slats as near the center of the rail as possible.

7.3.5 Crib Side Static Test:

7.2.5.1 Upon completion of the cyclic test, apply a static load of 100 lb (45.4 kg) at the point of impact testing while the side is supported by the top rail at a point vertically in line with the point of load application (see Fig. 7):

7.2.5.2 The contact area for the load and reaction support shall be the same as the impact area previously defined.

7.2.5.3 Apply this load gradually within a period of 5 s and maintain it for an additional 30 s.

7.2.6 Stationary Side Cyclic Test:

7.2.6.1 Assemble the stationary side to the crib in accordance with manufacturer's instructions.

7.2.6.2 Secure the bottom ends of the crib to eliminate horizontal motion at the base.

7.2.6.3 Allow the 30-lb (13.6-kg) weight to free-fall 3 in. (76 mm) 250 times at a rate of 4 ± 1 s/cycle such that it impacts directly upon the 0.375-in. (9-mm) thick rubber pad located on the top surface of the bottom rail between two adjacent spindles or slats as near the center of the rail as possible.

7.2.7 Stationary Side Static Test:

7.2.7.1 The stationary side will remain mounted to the crib for this portion of the test.

7.2.7.2 Upon completion of the cyclic test, apply a weight of 100 lb (45.4 kg) at the point of impact testing while the side is supported on the top rail at a point vertically in line with the point of weight application (see Fig. 7) for location of weight only.

7.2.7.3 The contact area for the load and reaction support shall be the same as the impact area previously defined.

7.2.7.4 Apply the weight gradually within a period of 5 s and maintain it for an additional 30 s.

7.2.8

7.3.5.1 Upon completion of the cyclic test, apply a weight of 100 lb (45.4 kg) at the point of impact testing while the side is supported on the top rail at a point vertically in line with the point of weight application.

7.3.5.2 The contact area for the load and reaction support shall be the same as the impact area previously defined.

7.3.5.3 Apply the weight gradually within a period of 5 s and maintain it for an additional 30 s.

7.3.6 Crib Side Spindle/Slat Torque Test:

7.2.8.1 Apply 7.3.6.1 Apply a torque of 30 lbf-in. (3.4 N-m) at the midpoint in height of each spindle or slat.

7.3.7.4 Mattress Support System Test:

7.3.1

7.4.1 General—This test assists in evaluating the integrity of the attachment of the mattress support to the crib. A vertically