

FINAL  
DRAFT

INTERNATIONAL  
STANDARD

ISO/FDIS  
7176-14

ISO/TC 173/SC 1

Secretariat: SABS

Voting begins on:  
2021-08-27

Voting terminates on:  
2021-10-22

---

---

## Wheelchairs —

Part 14:

## Power and control systems for electrically powered wheelchairs and scooters — Requirements and test methods

iTeh STANDARD PREVIEW

(standards.iteh.ai)

*Fauteuils roulants —*

*Partie 14: Systèmes d'alimentation et de commande des fauteuils  
roulants et des scooters électriques — Exigences et méthodes d'essai*

<https://standards.iteh.ai/catalog/standards/sist/f8a1ce71-2d9f-4124-84da-713d5fcec586/iso-fdis-7176-14>

RECIPIENTS OF THIS DRAFT ARE INVITED TO SUBMIT, WITH THEIR COMMENTS, NOTIFICATION OF ANY RELEVANT PATENT RIGHTS OF WHICH THEY ARE AWARE AND TO PROVIDE SUPPORTING DOCUMENTATION.

IN ADDITION TO THEIR EVALUATION AS BEING ACCEPTABLE FOR INDUSTRIAL, TECHNOLOGICAL, COMMERCIAL AND USER PURPOSES, DRAFT INTERNATIONAL STANDARDS MAY ON OCCASION HAVE TO BE CONSIDERED IN THE LIGHT OF THEIR POTENTIAL TO BECOME STANDARDS TO WHICH REFERENCE MAY BE MADE IN NATIONAL REGULATIONS.



Reference number  
ISO/FDIS 7176-14:2021(E)

© ISO 2021

**iTeh STANDARD PREVIEW**  
**(standards.iteh.ai)**

ISO/FDIS 7176-14

<https://standards.iteh.ai/catalog/standards/sist/f8a1ce71-2d9f-4124-84da-713d5fcc586/iso-fdis-7176-14>



**COPYRIGHT PROTECTED DOCUMENT**

© ISO 2021

All rights reserved. Unless otherwise specified, or required in the context of its implementation, no part of this publication may be reproduced or utilized otherwise in any form or by any means, electronic or mechanical, including photocopying, or posting on the internet or an intranet, without prior written permission. Permission can be requested from either ISO at the address below or ISO's member body in the country of the requester.

ISO copyright office  
CP 401 • Ch. de Blandonnet 8  
CH-1214 Vernier, Geneva  
Phone: +41 22 749 01 11  
Email: [copyright@iso.org](mailto:copyright@iso.org)  
Website: [www.iso.org](http://www.iso.org)

Published in Switzerland

# Contents

	Page
<b>Foreword</b> .....	<b>vii</b>
<b>Introduction</b> .....	<b>viii</b>
<b>1 Scope</b> .....	<b>1</b>
<b>2 Normative references</b> .....	<b>1</b>
<b>3 Terms and definitions</b> .....	<b>2</b>
<b>4 Apparatus</b> .....	<b>5</b>
<b>5 Preparation of test wheelchair</b> .....	<b>9</b>
5.1 Wheelchair set-up.....	9
5.2 Loading the wheelchair.....	9
5.3 Wheelchair attributes.....	9
5.4 Wheelchair documentation.....	9
5.5 Preparation records.....	10
<b>6 Guidance for tests</b> .....	<b>10</b>
6.1 Test order.....	10
6.2 Batteries.....	10
6.3 Test conditions.....	10
<b>7 Single fault safety</b> .....	<b>10</b>
7.1 Single fault conditions.....	10
7.1.1 General.....	10
7.1.2 Requirements.....	10
7.2 Controller command signal processing failure.....	11
7.2.1 General.....	11
7.2.2 Requirements.....	11
7.2.3 Test method.....	11
7.3 Controller output device failure.....	14
7.3.1 General.....	14
7.3.2 Requirements.....	14
7.3.3 Test method.....	14
7.4 Ability to stop when power is removed.....	17
7.4.1 General.....	17
7.4.2 Requirements.....	17
7.4.3 Test method.....	17
<b>8 Design</b> .....	<b>18</b>
8.1 On/off switch.....	18
8.1.1 Requirements.....	18
8.1.2 Test method.....	18
8.2 Current consumption while switched off.....	19
8.2.1 General.....	19
8.2.2 Requirement.....	19
8.2.3 Test method.....	19
8.3 Control signal at switch on.....	19
8.3.1 Requirement.....	19
8.3.2 Test method.....	19
8.4 Safe operation as the battery set becomes depleted.....	20
8.4.1 General.....	20
8.4.2 Requirements.....	20
8.4.3 Test method.....	20
8.5 Over-discharge protection.....	22
8.5.1 Requirement.....	22
8.5.2 Test method.....	22
8.6 Controller over-voltage protection.....	23

8.6.1	General	23
8.6.2	Requirements	23
8.6.3	Test method	23
8.7	Switch-off while driving	23
8.7.1	General	23
8.7.2	Requirements	23
8.7.3	Test method	24
8.8	Measuring devices	24
8.8.1	General	24
8.8.2	Battery gauge	24
8.9	Drive inhibit during charging	25
8.9.1	General	25
8.9.2	Requirement	25
8.9.3	Test method	25
8.10	Charging connection voltage drop	25
8.10.1	General	25
8.10.2	Requirements	25
8.10.3	Test method	26
8.11	Non-powered mobility	26
8.11.1	General	26
8.11.2	Requirements	26
8.11.3	Brake release	27
8.11.4	Test method	27
8.12	Brakes	28
8.12.1	General	28
8.12.2	Requirement	28
8.13	Battery enclosures	29
8.13.1	Requirements	29
8.13.2	Test method	29
8.14	Symbols	29
8.15	Safety of moving parts	29
8.15.1	General	29
8.15.2	Requirements	30
8.16	Software faults	30
8.16.1	General	30
8.16.2	Requirements	30
8.17	Use in combination with other devices	30
8.17.1	General	30
8.18	Wireless technology	31
8.18.1	General	31
8.18.2	Wireless technology related labelling	31
8.18.3	Risk assessment	31
8.18.4	Wireless coexistence testing and verification	32
8.19	Maintenance and evaluation	32
<b>9</b>	<b>Protection against electric shock, burns, fire and explosion</b>	<b>32</b>
9.1	Electrical Isolation of a wheelchair frame	32
9.1.1	General	32
9.1.2	Requirements	33
9.1.3	Test method	33
9.2	Protection from non-insulated electrical parts	33
9.2.1	General	33
9.2.2	Requirement	33
9.2.3	Test method	34
9.3	Circuit protection	34
9.3.1	General	34
9.3.2	Requirements	34
9.3.3	Test methods	35
9.4	Stalled condition protection	39

9.4.1	General	39
9.4.2	Requirements	39
9.4.3	Test method	40
9.5	Maximum thermal drive test	41
9.5.1	General	41
9.5.2	Test method	41
9.6	Surface temperatures	43
9.7	Isolation of battery system	43
9.7.1	General	43
9.7.2	Requirement	44
9.7.3	Isolate switch requirements	44
9.7.4	Implementation	44
9.7.5	Test Methods	45
9.8	Resistance to ignition	45
9.8.1	General	45
9.8.2	Requirements	45
<b>10</b>	<b>Ergonomics</b>	<b>45</b>
10.1	Operator interface	45
10.2	Operating forces	46
10.2.1	General	46
10.2.2	Requirements	46
10.2.3	Test method	46
10.3	Display position	48
10.4	On/off indicator	48
10.5	Connectors	48
10.6	Audible noise	48
10.6.1	General	48
10.6.2	Requirement	48
10.6.3	Test method	48
10.6.4	Ancillary equipment test	49
10.7	Acoustic warning device	50
10.7.1	General	50
10.7.2	Requirements	50
10.7.3	Test method	50
<b>11</b>	<b>Durability</b>	<b>51</b>
11.1	Control devices	51
11.1.1	General	51
11.1.2	Requirement	51
11.2	Switches	52
11.2.1	General	52
11.2.2	Durability requirements	52
11.2.3	Safety requirements	52
11.3	Connectors	52
11.3.1	General	52
11.3.2	Requirements	52
<b>12</b>	<b>Electrical connections</b>	<b>53</b>
12.1	Interchangeability	53
12.2	Wire routing	53
12.2.1	General	53
12.2.2	Requirements	53
12.2.3	Test method	53
12.3	Wire colours	53
12.4	Intermediate battery connection power drains	54
12.4.1	General	54
12.4.2	Requirements	54
12.4.3	Test method	54

<b>13</b>	<b>Environmental</b>	<b>54</b>
13.1	Substance/liquid ingress (in)	54
13.2	Leakage of substances (out)	54
13.3	Electromagnetic compatibility	54
13.4	Biocompatibility and toxicity	54
<b>14</b>	<b>Misuse and abuse</b>	<b>55</b>
14.1	Reversed polarity at the battery set	55
14.1.1	General	55
14.1.2	Requirements	55
14.1.3	Test method	55
14.2	Integrity of enclosures	55
14.2.1	General	55
14.2.2	Requirements	56
14.2.3	Test method	56
14.3	Protection against unauthorized access	56
<b>15</b>	<b>Information provided with the wheelchair related to control systems</b>	<b>56</b>
15.1	General	56
15.2	Operator diagrams	57
15.3	Operation of wheelchair	57
15.4	Safety information provided to operators	58
15.5	Removable parts	58
<b>16</b>	<b>Test report</b>	<b>58</b>
<b>17</b>	<b>Disclosure</b>	<b>59</b>
<b>Annex A</b> (informative)	<b>Guidance on wheelchair wire sizing and protection</b>	<b>60</b>
<b>Annex B</b> (informative)	<b>Guidance to estimate reverberation time for an acoustic area</b>	<b>62</b>
<b>Annex C</b> (informative)	<b>Guidance for switch circuit design</b>	<b>63</b>
<b>Bibliography</b>		<b>65</b>

iTech STANDARD PREVIEW  
(standards.iteh.ai)

ISO/FDIS 7176-14  
<https://standards.iteh.ai/catalog/standards/sist/f8a1ce71-2d9f-4124-84da-713d5fccc586/iso-fdis-7176-14>

## Foreword

ISO (the International Organization for Standardization) is a worldwide federation of national standards bodies (ISO member bodies). The work of preparing International Standards is normally carried out through ISO technical committees. Each member body interested in a subject for which a technical committee has been established has the right to be represented on that committee. International organizations, governmental and non-governmental, in liaison with ISO, also take part in the work. ISO collaborates closely with the International Electrotechnical Commission (IEC) on all matters of electrotechnical standardization.

The procedures used to develop this document and those intended for its further maintenance are described in the ISO/IEC Directives, Part 1. In particular, the different approval criteria needed for the different types of ISO documents should be noted. This document was drafted in accordance with the editorial rules of the ISO/IEC Directives, Part 2 (see [www.iso.org/directives](http://www.iso.org/directives)).

Attention is drawn to the possibility that some of the elements of this document may be the subject of patent rights. ISO shall not be held responsible for identifying any or all such patent rights. Details of any patent rights identified during the development of the document will be in the Introduction and/or on the ISO list of patent declarations received (see [www.iso.org/patents](http://www.iso.org/patents)).

Any trade name used in this document is information given for the convenience of users and does not constitute an endorsement.

For an explanation of the voluntary nature of standards, the meaning of ISO specific terms and expressions related to conformity assessment, as well as information about ISO's adherence to the World Trade Organization (WTO) principles in the Technical Barriers to Trade (TBT), see [www.iso.org/iso/foreword.html](http://www.iso.org/iso/foreword.html).

This document was prepared by Technical Committee ISO/TC 173, *Assistive products*, Subcommittee SC 1, *Wheelchairs*.

This third edition cancels and replaces the second edition (ISO 7176 14:2008), which has been technically revised.

The main changes compared to the previous edition are as follows:

- addition of provisions on the following:
  - wireless communication technology;
  - thermal drive test;
  - occupant operable battery isolation switch;
  - battery chemistries other than lead-acid.

A list of all parts in the ISO 7176 series can be found on the ISO website.

Any feedback or questions on this document should be directed to the user's national standards body. A complete listing of these bodies can be found at [www.iso.org/members.html](http://www.iso.org/members.html).

## Introduction

Electronic control systems in electric powered wheelchairs and scooters are critical for the safety, functionality and reliability of the vehicle.

This document specifies some wheelchair tests that are conducted on an inclined test plane. The intention of these tests is not to evaluate the performance of a wheelchair at the maximum gradient on which it is capable of operating. Instead, the objective is to reveal any changes in the wheelchair's behaviour that might occur under fault conditions, and these changes are more readily discovered when it is operated on a slope. For convenience, the inclined test plane has a fixed gradient, representative of those on which the wheelchair might be used.

The range of ambient temperatures under which testing is carried out is limited to allow comparison between the performance of a wheelchair in normal operation and performance when faults are introduced.

With inter-module wireless communication becoming more common with the possibility that the communication may cause changes in the behaviour of other devices, a subclause has been added to assist with an associated safety assessment.

## iTeh STANDARD PREVIEW (standards.iteh.ai)

[ISO/FDIS 7176-14](https://standards.iteh.ai/catalog/standards/sist/f8a1ce71-2d9f-4124-84da-713d5fcec586/iso-fdis-7176-14)

<https://standards.iteh.ai/catalog/standards/sist/f8a1ce71-2d9f-4124-84da-713d5fcec586/iso-fdis-7176-14>



# Wheelchairs —

## Part 14:

# Power and control systems for electrically powered wheelchairs and scooters — Requirements and test methods

## 1 Scope

This document specifies requirements and associated test methods for the power, and-control systems of electrically powered wheelchairs and scooters. It sets safety and performance requirements that apply during normal use and some conditions of abuse and failure. It also specifies methods of measurement of the forces necessary to operate controls and sets limits on the forces needed for some operations.

This document is applicable to electrically powered wheelchairs and scooters with a maximum speed no greater than 15 km/h intended to provide indoor and/or outdoor mobility for one disabled person whose mass lies in the range specified in ISO 7176-11.

## 2 Normative references (standards.iteh.ai)

The following documents are referred to in the text in such a way that some or all of their content constitutes requirements of this document. For dated references, only the edition cited applies. For undated references, the latest edition of the referenced document (including any amendments) applies.

EN 12182, *Assistive products for persons with disability — General requirements and test methods*

IEC 60332-1-2, *Tests on electrical and optical fibre cables under fire conditions - Part 1-2: Test for vertical flame propagation for a single insulated wire or cable - Procedure for 1 kW pre-mixed flame*

IEC 60417, *Graphical symbols for use on equipment*

IEC 60529, *Degrees of protection provided by enclosures (IP Code)*

IEC 60601-1:2005+AMD1:2012, *Medical electrical equipment — Part 1: General requirements for basic safety and essential performance*

IEC 61032, *Protection of persons and equipment by enclosures — Probes for verification*

IEC 62262, *Degrees of protection provided by enclosures for electrical equipment against external mechanical impacts (IK code)*

IEC 62304, *Medical device software – Software life cycle processes*

ISO 10993-1, *Biological evaluation of medical devices — Part 1: Evaluation and testing within a risk management process*

ISO 7176-2, *Wheelchairs — Part 2: Determination of dynamic stability of electrically powered wheelchairs*

ISO 7176-3, *Wheelchairs — Part 3: Determination of effectiveness of brakes*

ISO 7176-4, *Wheelchairs — Part 4: Energy consumption of electric wheelchairs and scooters for determination of theoretical distance range*

## ISO/FDIS 7176-14:2021(E)

ISO 7176-6, *Wheelchairs — Part 6: Determination of maximum speed of electrically powered wheelchairs*

ISO 7176-10, *Wheelchairs — Part 10: Determination of obstacle-climbing ability of electrically powered wheelchairs*

ISO 7176-13, *Wheelchairs — Part 13: Determination of coefficient of friction of test surfaces*

ISO 7176-15, *Wheelchairs — Part 15: Requirements for information disclosure, documentation and labelling*

ISO 7176-21:2009, *Wheelchairs — Part 21: Requirements and test methods for electromagnetic compatibility of electrically powered wheelchairs and scooters, and battery chargers*

ISO 7176-22, *Wheelchairs — Part 22: Set-up procedures*

ISO 7176-26, *Wheelchairs — Part 26: Vocabulary*

ISO 13732-1, *Ergonomics of the thermal environment — Methods for the assessment of human responses to contact with surfaces — Part 1: Hot surfaces*

ISO 14971, *Medical devices — Application of risk management to medical devices*

UL 94, *Tests for flammability of plastic materials for parts in devices and appliances*

### 3 Terms and definitions

For the purposes of this document, the terms and definitions given in ISO 7176-26 and the following apply.

ISO and IEC maintain terminological databases for use in standardization at the following addresses:

— ISO Online browsing platform: available at <https://www.iso.org/obp>

— IEC Electropedia: available at <http://www.electropedia.org/>

#### 3.1

##### **analogue signal**

signal in which the characteristic quantity representing information can at any instant assume any value within a continuous interval

Note 1 to entry: An analogue signal can follow continuously the values of another physical quantity representing information.

[SOURCE: IEV 702-04-02]

#### 3.2

##### **battery**

one or more cells that are electrically connected together and fitted with devices necessary for use

EXAMPLE Case, terminals, marking and protective devices.

[SOURCE: IEV 482-01-04, modified]

#### 3.3

##### **battery charger**

device that is connected to supply mains and to a battery set for the purpose of charging the batteries

#### 3.4

##### **battery compartment**

removable or non-removable enclosure for one or more batteries

#### 3.5

##### **battery set**

set of interconnected batteries used to power a wheelchair

**3.6****battery terminal**

terminal on a battery to which a cable or connector can be connected

**3.7****capacity**

electric charge that a cell or battery can deliver under specified discharge conditions

Note 1 to entry: The SI unit for electric charge is the coulomb, C [1 C = 1 A·s (ampere-second)] but in practice, capacity is usually expressed in ampere-hour (A·h) or watt-hour (W·h).

[SOURCE: IEC 482-03-14, modified]

**3.8****charge completion voltage**

voltage, normally specified by the battery manufacturer, to which a battery is charged in defined circumstances, required to assure that a battery can be fully charged

**3.9****charge rate**

electric current at which a secondary cell or battery is charged

Note 1 to entry: The charge rate is expressed as the reference current  $I_t = C_r/n$  where  $C_r$  is the rated capacity declared by the manufacturer and  $n$  is the time base in hours for which the rated capacity is declared.

[SOURCE: IEC 482-05-45]

**3.10****coexistence**

ability of two or more spectrum-dependent devices or networks to operate without harmful interference.

Note 1 to entry: Spectrum dependence may include, but is not limited to radio, ultrasound and infrared.

[SOURCE: IEEE Std 1900.1:2008, B28]

**3.11****command signal**

electrical signal from the control device

**3.12****control device**

device with which the operator indicates the desired speed and/or direction of movement of the wheelchair and can optionally control their position within the wheelchair

Note 1 to entry: A control device can be an integral part of a controller.

**3.13****controller**

electrical devices, circuits, and the case(s) in which they are housed, that are used to convert the operator's indication of desired speed and/or direction of movement into the appropriate power that is supplied to the motor(s)

**3.14****cut-off voltage**

voltage specified by the battery manufacturer at which the discharge of a battery is considered finished

[SOURCE: IEC 482-03-30]

**3.15  
discharge rate**

electric current at which a battery is discharged

Note 1 to entry: The discharge rate is calculated as the rated capacity divided by the corresponding discharge time, which results in an electric current.

[SOURCE: IEC 482-03-25]

**3.16  
draught-free environment**

space in which the results of experiments are not significantly affected by the local air speed

Note 1 to entry: A qualitative example is a space in which a wax candle flame remains essentially undisturbed. Quantitative examples are small-scale fire tests in which a maximum air speed of 0,1 m·s<sup>-1</sup> or 0,2 m·s<sup>-1</sup> is sometimes specified.

[SOURCE: ISO 13943:2017, 3.83]

**3.17  
enclosure**

part providing protection of equipment against certain external influences and, in any direction, protection against contact

Note 1 to entry: Enclosures provide protection of equipment against harmful effects of mechanical impacts.

Note 2 to entry: Barriers, shapes of openings or any other means – whether attached to the enclosure or formed by the enclosed equipment – suitable to prevent or limit the penetration of the specified test probes, are considered as a part of the enclosure, except when they can be removed without the use of a key or tool.

**3.18  
entry point**

output terminals of the battery charger for on-board, off-board and carry-on chargers

TECHNICAL STANDARD PREVIEW  
(standards.iteh.ai)  
ISO/FDIS 7176-14  
http://standards.iteh.ai/catalog/standards/sist/713d5fccc586/iso-fdis-7176-14

**3.19  
harm**

physical injury or damage to the health of people or animals, or damage to property or the environment

[SOURCE: IEC 60601-1:2005+AMD1:2012, 3.38]

**3.20  
hazard**

potential source of harm

[SOURCE: IEC 60601-1:2005+AMD1:2012, 3.39]

**3.21  
hazardous situation**

circumstance in which people, property or the environment are exposed to one or more hazard(s)

[SOURCE: IEC 60601-1:2005+AMD1:2012, 3.40]

**3.22  
latched control**

function that remains active without continuous input from the operator

**3.23  
leakage current**

electric current in an unwanted conductive path other than a short circuit

[SOURCE: IEC 151-15-49]

**3.24****pinch point**

location at which a moving part comes into contact with or close proximity to another part such that another object at that location would be cut or crushed

**3.25****single fault condition**

condition in which a single means for reducing a risk is defective or a single abnormal condition is present

[SOURCE: IEC 60601-1:2005+AMD1:2012, 3.115, modified]

**3.26****switch**

mechanical switching device capable of making, carrying and breaking currents under normal operating conditions which might include specified operating conditions, overload conditions and also carrying for a specified time currents under specified abnormal circuit conditions such as those of short circuit

Note 1 to entry: A switch may be capable of making but not breaking short circuit currents.

[SOURCE: IEC 441-14-10]

**3.28****terminal**

conductive part of a device, electric circuit or electric network, provided for connecting that device, electric circuit or electric network to one or more external conductors

Note 1 to entry: Removable bolts, screws and fasteners are not considered part of a terminal.

[SOURCE: IEC 151-12-12]

[ISO/FDIS 7176-14](https://standards.iteh.ai/catalog/standards/sist/f8a1ce71-2d9f-4124-84da-713d5fcec586/iso-fdis-7176-14)

<https://standards.iteh.ai/catalog/standards/sist/f8a1ce71-2d9f-4124-84da-713d5fcec586/iso-fdis-7176-14>

**3.29****theoretical state of charge**

electric charge added to a fully discharged battery by charging at a known charge rate for a known time, or estimated to remain in a battery that has been fully charged and then discharged at a known discharge rate for a known time, and expressed as a percentage of the rated capacity

**4 Apparatus**

**4.1 Inclined test plane**, with a surface of sufficient friction as specified in ISO 7176-13 to cause minimal wheel slippage, of sufficient size to enable the applicable tests specified in this document to be performed and with a marker from which wheelchair stopping distance can be measured.

The inclined test plane shall be able to be fixed at 3°, 6° or 10° to the horizontal. The 6° gradient shall be used unless the loaded wheelchair (see 5.2) is unable to climb at a speed greater than 0,5 km/h or where its primary purpose specified by the manufacturer is for indoor use in which case the gradient shall be set at 3°.

NOTE 1 A ramp approximately 10 m × 3 m is normally of sufficient area, but the testing of larger and/or faster wheelchairs might need a larger ramp.

NOTE 2 Alternative slopes can be required for certain tests, refer to ISO 7176-6:2018, Annex A.

**4.2 Horizontal test plane**, with the same high-friction surface as the inclined test plane (4.1), and of sufficient size to enable the applicable tests specified in this document to be performed.

NOTE An area of approximately 10 m × 3 m is normally of sufficient size but the testing of larger and/or faster wheelchairs might need a larger test plane.

**4.3 Acoustic test area**, marked on a horizontal plane in a room with an ambient noise level not exceeding 55 dB(A-weighted) and of sufficient length for the wheelchair to attain its maximum speed before reaching the test area specified in [10.6](#) and to stop safely beyond the test area.

The room shall also have a mean reverberation time ( $R_T$ ) less than 0,5 s for frequencies from 125 Hz to 4 kHz at the position where sound pressure levels are measured. See [Annex B](#) for guidance on estimation of reverberation time.

The test floor shall be uncoated concrete in the area where the chair is driven.

**4.4 Means for measuring** and recording speed up to 5 m/s, with an accuracy of  $\pm 0,1$  m/s and a sample rate of at least 60 Hz. for digital measuring devices.

**4.5 Means of measuring stopping distance of a wheelchair**, to an accuracy of  $\pm 100$  mm.

NOTE It is important that the means for measuring the speed ([4.4](#)) and stopping distance give the required accuracy. Suitable methods include, but are not limited to:

- a) a photocell-operated interrupting switch capable of detecting reflective tape or a light source on the test plane;
- b) a "fifth wheel" capable of recording the distance travelled where the recording device can be started by the interrupting switch.

**4.6 Voltage source**, with a voltage adjustable in the range  $0,25 U_B$  to  $1,5 U_B$ , where  $U_B$  is the nominal voltage of the battery set, expressed in volts.

The voltage source shall be capable of supplying the peak current drawn from the battery set during wheelchair operation and shall be capable of sinking the peak current returned to the battery during wheelchair operation. Any change in the voltage shall be no greater than 5 % of  $U_B$  while the current is within this range.

<https://standards.iteh.ai/catalog/standards/sist/f8a1ce71-2d9f-4124-84da-713d5fcc586/iso-fdis-7176-14>

**4.7 Test probe B**, as specified in IEC 61032.

**4.8 Test probe 18**, as specified in IEC 61032.

**4.9 Test probe 11**, as specified in IEC 61032, capable of attachment to a force measuring instrument ([4.11](#)). See [Figure 1](#).

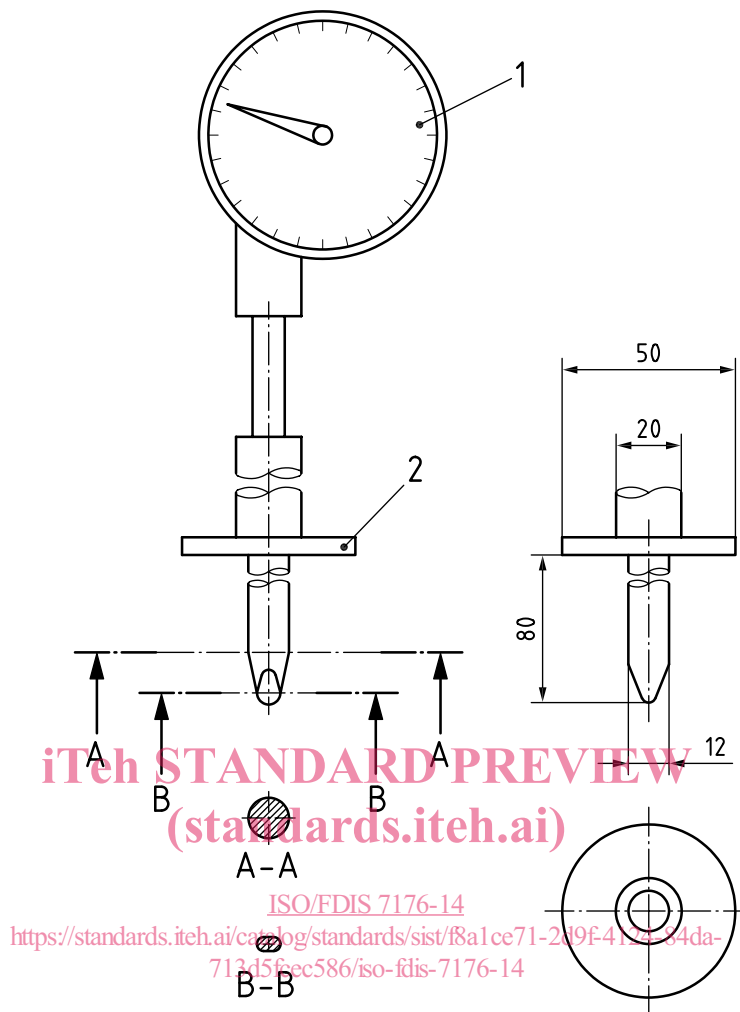
**Key**

- 1 force measuring instrument
- 2 stop plate

**Figure 1 — Test probe 11**

**4.10 Small unjointed test probe**, constructed as specified for test probe 18 (4.8), but without joints, and capable of attachment to a force measuring instrument (4.11) both with and without the handle extension.

**4.11 Force measuring instrument**, capable of measuring forces in the range of 0 N to 150 N in increments of 1 N with an accuracy of  $\pm 1$  N.

**4.12 Force measuring instrument for control devices**, capable of measuring forces in a range of 0 N to 10 N in 0,1 N increments with an accuracy of  $\pm 0,1$  N, and that can be fitted with a rigid spherical tip of radius  $5,0 \text{ mm} \pm 0,2 \text{ mm}$ .

**4.13 Positive differential air pressure measuring device**, capable of measuring positive differential air pressure, relative to local atmospheric pressure, in a range of 0 kPa to 20 kPa in 200 Pa increments with an accuracy of  $\pm 200$  Pa.