**Safety of machinery — Supporting
protective system**

Sécurité des machines — Système de protection complémentaire

iTeh STANDARD PREVIEW
(standards.iteh.ai)

[ISO/PRE TR 22053](https://standards.iteh.ai/catalog/standards/sist/a456c97c-4df6-42bb-ac7a-505c8b927113/iso-prf-tr-22053)

<https://standards.iteh.ai/catalog/standards/sist/a456c97c-4df6-42bb-ac7a-505c8b927113/iso-prf-tr-22053>

PROOF / ÉPREUVE



iTeh STANDARD PREVIEW (standards.iteh.ai)

ISO/PRE TR 22053

<https://standards.iteh.ai/catalog/standards/sist/a456c97c-4df6-42bb-ac7a-505c8b927113/iso-prf-tr-22053>



COPYRIGHT PROTECTED DOCUMENT

© ISO 2020

All rights reserved. Unless otherwise specified, or required in the context of its implementation, no part of this publication may be reproduced or utilized otherwise in any form or by any means, electronic or mechanical, including photocopying, or posting on the internet or an intranet, without prior written permission. Permission can be requested from either ISO at the address below or ISO's member body in the country of the requester.

ISO copyright office
CP 401 • Ch. de Blandonnet 8
CH-1214 Vernier, Geneva
Phone: +41 22 749 01 11
Email: copyright@iso.org
Website: www.iso.org

Published in Switzerland

Contents

	Page
Foreword.....	iv
Introduction.....	v
1 Scope.....	1
2 Normative references.....	1
3 Terms and definitions.....	1
4 Symbols and abbreviated terms.....	2
5 Safeguarding supportive system.....	2
5.1 General.....	2
5.2 Description of safeguarding supportive system.....	3
5.3 Interface between SSS and SRP/CS.....	3
6 Design of safeguarding supportive system.....	4
6.1 General.....	4
6.2 System components.....	4
6.2.1 General.....	4
6.2.2 Identification elements.....	4
6.2.3 Human-SSS interface.....	5
6.2.4 Logic unit.....	5
6.3 Output from the credential database.....	5
6.4 Verification and validation.....	5
7 Information for use.....	6
Annex A (informative) Visualization of integration of SSS within IMS.....	7
Bibliography.....	8

ISO/PRE TR 22053

<https://standards.iteh.ai/catalog/standards/sist/a456c97c-4df6-42bb-ac7a-505c8b927113/iso-prf-tr-22053>

Foreword

ISO (the International Organization for Standardization) is a worldwide federation of national standards bodies (ISO member bodies). The work of preparing International Standards is normally carried out through ISO technical committees. Each member body interested in a subject for which a technical committee has been established has the right to be represented on that committee. International organizations, governmental and non-governmental, in liaison with ISO, also take part in the work. ISO collaborates closely with the International Electrotechnical Commission (IEC) on all matters of electrotechnical standardization.

The procedures used to develop this document and those intended for its further maintenance are described in the ISO/IEC Directives, Part 1. In particular, the different approval criteria needed for the different types of ISO documents should be noted. This document was drafted in accordance with the editorial rules of the ISO/IEC Directives, Part 2 (see www.iso.org/directives).

Attention is drawn to the possibility that some of the elements of this document may be the subject of patent rights. ISO shall not be held responsible for identifying any or all such patent rights. Details of any patent rights identified during the development of the document will be in the Introduction and/or on the ISO list of patent declarations received (see www.iso.org/patents).

Any trade name used in this document is information given for the convenience of users and does not constitute an endorsement.

For an explanation of the voluntary nature of standards, the meaning of ISO specific terms and expressions related to conformity assessment, as well as information about ISO's adherence to the World Trade Organization (WTO) principles in the Technical Barriers to Trade (TBT), see www.iso.org/iso/foreword.html.

This document was prepared by Technical Committee ISO/TC 199, *Safety of machinery*.

Any feedback or questions on this document should be directed to the user's national standards body. A complete listing of these bodies can be found at www.iso.org/members.html.

Introduction

This document was developed to provide information about systems incorporating measures that can be introduced into machinery, especially in IMS for reducing risks based on human factors.

Due to lack of human attentiveness during any task performed in a hazard zone (for example, inspections, maintenance or set-up), safeguarding supportive systems can be used as a technical measure to minimize the probability of dangerous human errors occurring.

The International Organization for Standardization (ISO) and International Electrotechnical Commission (IEC) draw attention to the fact that it is claimed that compliance with this document may involve the use of a patent.

ISO and IEC take no position concerning the evidence, validity and scope of this patent right.

The holder of this patent right has assured ISO and IEC that he/she is willing to negotiate licences under reasonable and non-discriminatory terms and conditions with applicants throughout the world. In this respect, the statement of the holder of this patent right is registered with ISO and IEC. Information may be obtained from the patent database available at www.iso.org/patents.

Attention is drawn to the possibility that some of the elements of this document may be the subject of patent rights other than those in the patent database. ISO and IEC shall not be held responsible for identifying any or all such patent rights.

iTeh STANDARD PREVIEW (standards.iteh.ai)

[ISO/PRE TR 22053](#)

<https://standards.iteh.ai/catalog/standards/sist/a456c97c-4df6-42bb-ac7a-505c8b927113/iso-prf-tr-22053>

iTeh STANDARD PREVIEW
(standards.iteh.ai)

ISO/PRE TR 22053

<https://standards.iteh.ai/catalog/standards/sist/a456c97c-4df6-42bb-ac7a-505c8b927113/iso-prf-tr-22053>

Safety of machinery — Supporting protective system

1 Scope

This document provides guidance for the design and integration of a safeguarding supportive system (SSS) which is intended to include a mode selection as part of an SRP/CS or to add a layer of personnel authentication and authorization to an IMS designed according to ISO 11161.

This document is meant to be used in conjunction with ISO 11161.

This document is applicable to the SSS but does not address personnel qualification and competency.

2 Normative references

The following documents are referred to in the text in such a way that some or all of their content constitutes requirements of this document. For dated references, only the edition cited applies. For undated references, the latest edition of the referenced document (including any amendments) applies.

ISO 11161:2007, *Safety of machinery — Integrated manufacturing systems — Basic requirements*

ISO 12100:2010, *Safety of machinery — General principles for design — Risk assessment and risk reduction*

3 Terms and definitions (standards.iteh.ai)

For the purposes of this document, the terms and definitions given in ISO 11161, ISO 12100 and the following apply. https://standards.iteh.ai/catalog/standards/sist/a456c97c-4df6-42bb-ac7a-505c8b927113/iso-prf-tr-22053

ISO and IEC maintain terminological databases for use in standardization at the following addresses:

- ISO Online browsing platform: available at <https://www.iso.org/obp>
- IEC Electropedia: available at <http://www.electropedia.org/>

3.1 safeguarding supportive system

SSS

complementary risk reduction/protective measure to enable mode selection by the use of *authentication* (3.5) means

3.2 identification element

device used in the *safeguarding supportive system* (3.1), referring to all logic units and their peripheral equipment, but excluding the credential database

Note 1 to entry: Examples include readers, key switches, cameras, HMI's, industrial PLCs.

3.3 control zone

identified portion of an IMS coordinated by the control system

[SOURCE: ANSI B11.20:2017, 3.39.1]

**3.4
qualified personnel**

group of individuals who, as a result of training and experience, understands and demonstrates competence with the design, construction, operation or maintenance of the machine and the associated hazards

[SOURCE: ANSI B11.0:2020, 3.68, modified — In the definition, "group of" has been added.]

**3.5
authentication**

verification of the identity of a user, process, or device, often as a prerequisite to allowing access to resources in an information system

[SOURCE: ISO/TR 22100-4:2018, 3.3, modified — In the definition, "verifying" has been changed to "verification of".]

**3.6
authorization**

right or permission that is granted to a system entity to access a system resource

[SOURCE: ISO/TR 22100-4:2018, 3.4]

**3.7
authorized personnel**

qualified personnel identified by the user (employer) or supplier to perform a specific task

[SOURCE: ANSI B11.0:2015, 3.6]

STANDARD PREVIEW
(standards.iteh.ai)

4 Symbols and abbreviated terms

[ISO/PRE TR 22053](#)

HMI	human-machine interface
ID	identification
IMS	integrated manufacturing system
PLC	programmable logic controller
RF	radio frequency
RFID	radio frequency identification
SPE	sensitive protective equipment
SRP/CS	safety-related parts of a control system

5 Safeguarding supportive system

5.1 General

A safeguarding supportive system is used in conjunction with, and not in place of, guards and protective devices.

A safeguarding supportive system enables a requested mode when the authorization matches the requirements for the task to be performed.

The safeguarding supportive system affects all modes of operation requiring tasks in hazard zones including, for example, adjusting, set-up, teaching and troubleshooting. Accordingly, the safeguarding

supportive system functions are based on modes of operation of the IMS described in ISO 11161:2007, 5.1.3, 8.2.2, and 8.4, and ISO 12100:2010, 6.2.11.9.

Figure 1 shows a concept of the implementation of an SSS.

NOTE Details on SRP/CS are dealt with in ISO 13849-1. Details on IMS are given in ISO 11161.

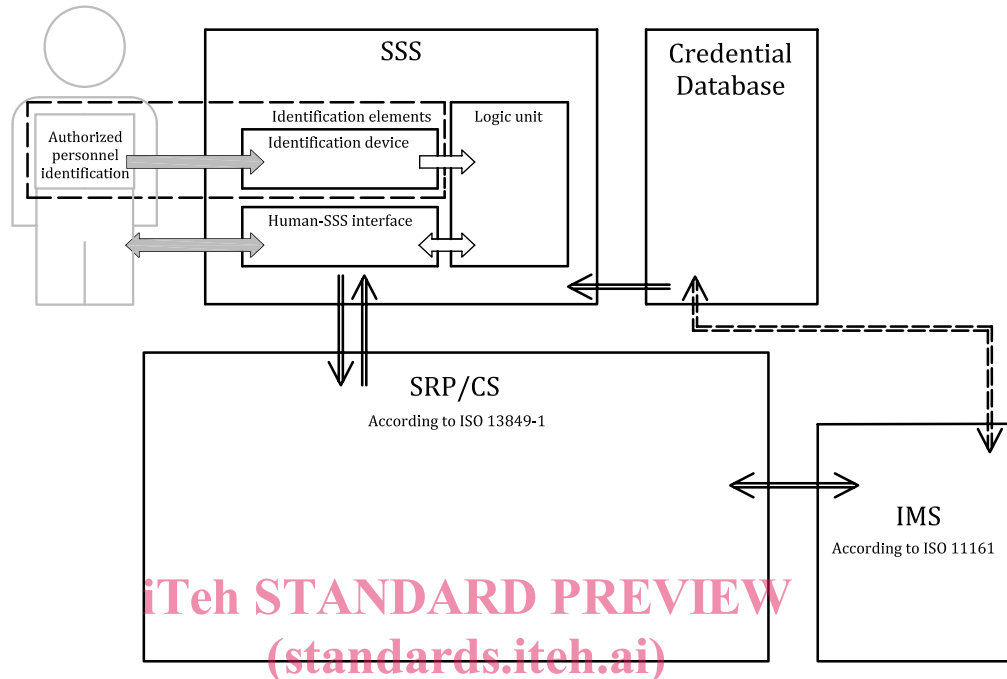

Figure 1 — Concept of the implementation of a SSS

<https://standards.itech.ai/catalog/standards/sist/a456c97c-4df6-42bb-ac7a-505c8b927113/iso-prf-tr-22053>

5.2 Description of safeguarding supportive system

Safeguarding supportive systems (SSS) provide the following functions:

- identification of authorized personnel;
- check that the authorization for the selected task matches with the personnel identified;
- information of the user about the task(s) authorized;
- enabling of the operating mode corresponding to the selected task(s);
- indication of the zones to be accessed by the authorized personnel.

The SSS is an additional layer which provides input(s) to the logic unit of the SRP/CS in order to enable the appropriate operating mode for the required task based on authentication. The mode selection itself is a safety function that requires SRP/CS with a performance level according to ISO 13849-1.

See also Figure A.1.

5.3 Interface between SSS and SRP/CS

The interface allows information exchange between SSS and the logic unit(s) of the SRP/CS. The safety functions enabled/disabled by the SSS can include but are not limited to:

- restart;
- reset;