

---

---

**Corrugating medium — Determination  
of the flat crush resistance after  
laboratory fluting —**

**Part 1:  
A-flute**

**iTeh STANDARD PREVIEW**  
*Papier cannelure — Détermination de la résistance à la compression  
à plat après cannelage en laboratoire —  
Partie 1: Cannelure A*  
**(standards.iteh.ai)**

ISO 7263-1:2018

<https://standards.iteh.ai/catalog/standards/sist/a3830fb5-4a44-4c0b-9abb-a3f398c572a1/iso-7263-1-2018>



**iTeh STANDARD PREVIEW**  
**(standards.iteh.ai)**

ISO 7263-1:2018

<https://standards.iteh.ai/catalog/standards/sist/a3830fb5-4a44-4c0b-9abb-a3f398c572a1/iso-7263-1-2018>



**COPYRIGHT PROTECTED DOCUMENT**

© ISO 2018

All rights reserved. Unless otherwise specified, or required in the context of its implementation, no part of this publication may be reproduced or utilized otherwise in any form or by any means, electronic or mechanical, including photocopying, or posting on the internet or an intranet, without prior written permission. Permission can be requested from either ISO at the address below or ISO's member body in the country of the requester.

ISO copyright office  
CP 401 • Ch. de Blandonnet 8  
CH-1214 Vernier, Geneva  
Phone: +41 22 749 01 11  
Fax: +41 22 749 09 47  
Email: [copyright@iso.org](mailto:copyright@iso.org)  
Website: [www.iso.org](http://www.iso.org)

Published in Switzerland

# Contents

	Page
Foreword.....	iv
Introduction.....	v
<b>1 Scope</b> .....	<b>1</b>
<b>2 Normative references</b> .....	<b>1</b>
<b>3 Terms and definitions</b> .....	<b>1</b>
<b>4 Principle</b> .....	<b>2</b>
<b>5 Apparatus</b> .....	<b>2</b>
<b>6 Sampling</b> .....	<b>4</b>
<b>7 Conditioning</b> .....	<b>4</b>
<b>8 Preparation of test pieces</b> .....	<b>4</b>
<b>9 Procedure</b> .....	<b>5</b>
9.1 General.....	5
9.2 Testing immediately after fluting.....	5
9.3 Testing after 30 min of reconditioning.....	5
9.4 Fluting and testing.....	5
<b>10 Expression of results</b> .....	<b>6</b>
10.1 Flat crush resistance.....	6
<b>11 Test report</b> .....	<b>6</b>
<b>Annex A (informative) Maintenance of fluting rolls (horizontal type)</b> .....	<b>8</b>
<b>Annex B (informative) Precision data</b> .. ISO 7263-1:2018.....	<b>9</b>
<b>Bibliography</b> ..... <a href="https://standards.iteh.ai/catalog/standards/sist/a3830fb5-4a44-4c0b-9abb-a3f398c572a1/iso-7263-1-2018">https://standards.iteh.ai/catalog/standards/sist/a3830fb5-4a44-4c0b-9abb-a3f398c572a1/iso-7263-1-2018</a>	<b>12</b>

## Foreword

ISO (the International Organization for Standardization) is a worldwide federation of national standards bodies (ISO member bodies). The work of preparing International Standards is normally carried out through ISO technical committees. Each member body interested in a subject for which a technical committee has been established has the right to be represented on that committee. International organizations, governmental and non-governmental, in liaison with ISO, also take part in the work. ISO collaborates closely with the International Electrotechnical Commission (IEC) on all matters of electrotechnical standardization.

The procedures used to develop this document and those intended for its further maintenance are described in the ISO/IEC Directives, Part 1. In particular, the different approval criteria needed for the different types of ISO documents should be noted. This document was drafted in accordance with the editorial rules of the ISO/IEC Directives, Part 2 (see [www.iso.org/directives](http://www.iso.org/directives)).

Attention is drawn to the possibility that some of the elements of this document may be the subject of patent rights. ISO shall not be held responsible for identifying any or all such patent rights. Details of any patent rights identified during the development of the document will be in the Introduction and/or on the ISO list of patent declarations received (see [www.iso.org/patents](http://www.iso.org/patents)).

Any trade name used in this document is information given for the convenience of users and does not constitute an endorsement.

For an explanation of the voluntary nature of standards, the meaning of ISO specific terms and expressions related to conformity assessment, as well as information about ISO's adherence to the World Trade Organization (WTO) principles in the Technical Barriers to Trade (TBT) see [www.iso.org/iso/foreword.html](http://www.iso.org/iso/foreword.html).

This document was prepared by Technical Committee ISO/TC 6, *Paper, board and pulps*, Subcommittee SC 2, *Test methods and quality specifications for paper and board*.

This document cancels and replaces ISO 7263:2011, which has been technically revised.

The main changes compared with ISO 7263:2011 are as follows:

- ISO 7263 has been divided into two parts due to technical developments to allow both A-flute (Part 1) and B-flute (Part 2) performance to be tested;
- [Clause 1](#): editorial changes have been made to the scope;
- [Clause 2](#): normative references have been updated;
- [Clause 7](#): this document requires conditioning of samples where testing will be carried out immediately after fluting, not only where test pieces will be reconditioned before testing;
- [9.2](#): for testing immediately after fluting the time between fluted test piece discharge and initial application of force has been increased to a more realistic level;
- [Clause 11](#): precision with more detailed description of precision data according to ISO/TR 24498 and TAPPI T 1200 has been moved to informative [Annex B](#);
- Test report is now [Clause 11](#) and has been updated;
- [Annex B](#): precision data according to ISO/TR 24498 and TAPPI T 1200 has been added.

A list of all parts in the ISO 7263 series can be found on the ISO website.

Any feedback or questions on this document should be directed to the user's national standards body. A complete listing of these bodies can be found at [www.iso.org/members.html](http://www.iso.org/members.html).

## Introduction

The flat crush resistance of laboratory-fluted corrugating medium is regarded as a property indicating the potential flat crush resistance of corrugated fibreboard made from that medium. The corrugated medium is fluted by passing it between heated rollers. Two different test procedures are used:

- a) the fluted corrugating medium is compressed immediately after fluting (i.e. 15 s to 25 s after fluting);
- b) the fluted corrugating medium is conditioned for 30 min to 35 min under standard laboratory test conditions before being compressed.

Since considerable advantages are claimed for both procedures and both are widely used, the ISO 7263 series describes both procedures. Procedure a) generally gives considerably higher results than those obtained with procedure b). The differences in results are claimed to be caused by the lower moisture content (and thus higher stiffness) of the unconditioned fluted corrugating medium, and/or the change in flute profile which occurs during the conditioning period.

This document describes the testing method for the A-flute geometry.

ISO 7263-2[6] describes the testing method for the B-flute geometry.

The option of using an A- or B-flute geometry is determined by the producer and/or the end-use customer; it is not required for any particular flute structure.

A method for determining the flat crush resistance of manufactured corrugated fibreboard is given in ISO 3035[3].

**ITeH STANDARD PREVIEW**  
**(standards.iteh.ai)**

[ISO 7263-1:2018](https://standards.iteh.ai/catalog/standards/sist/a3830fb5-4a44-4c0b-9abb-a3f398c572a1/iso-7263-1-2018)

<https://standards.iteh.ai/catalog/standards/sist/a3830fb5-4a44-4c0b-9abb-a3f398c572a1/iso-7263-1-2018>

**iTeh STANDARD PREVIEW**  
**(standards.iteh.ai)**

ISO 7263-1:2018

<https://standards.iteh.ai/catalog/standards/sist/a3830fb5-4a44-4c0b-9abb-a3f398c572a1/iso-7263-1-2018>

# Corrugating medium — Determination of the flat crush resistance after laboratory fluting —

## Part 1: A-flute

### 1 Scope

This document describes a method for the determination of the flat crush resistance of a corrugating medium after laboratory fluting using an A-flute geometry.

The procedure is applicable to any corrugating medium intended to be used, after fluting, in the manufacture of corrugated board.

NOTE ISO 7263-2 describes a method to determine the flat crush resistance using a B-flute geometry.

### 2 Normative references

The following documents are referred to in the text in such a way that some or all of their content constitutes requirements of this document. For dated references, only the edition cited applies. For undated references, the latest edition of the referenced document (including any amendments) applies.

ISO 187, *Paper, board and pulps — Standard atmosphere for conditioning and testing and procedure for monitoring the atmosphere and conditioning of samples*

ISO 13820, *Paper, board and corrugated fibreboard — Description and calibration of compression-testing equipment*

### 3 Terms and definitions

For the purposes of this document, the following terms and definitions apply.

ISO and IEC maintain terminological databases for use in standardization at the following addresses:

- ISO Online browsing platform: available at <https://www.iso.org/obp>
- IEC Electropedia: available at <http://www.electropedia.org/>

#### 3.1

##### **flat crush resistance**

maximum force that a corrugated test piece will withstand before the flutes collapse under an increasing force applied perpendicular to its surface

Note 1 to entry: The flat crush resistance is expressed in newtons (N).

#### 3.2

##### **flat crush resistance index**

*flat crush resistance* (3.1) divided by the grammage of the paper

Note 1 to entry: The result is expressed in newton square metres per gram (Nm<sup>2</sup>/g).

## 4 Principle

Fluting of the corrugating medium by passing it between heated rollers, and its formation into single-faced corrugated board using pressure-sensitive adhesive tape as the facing. Application of a crushing force, in the direction perpendicular to the plane of the flutes, and determination of the flat crush resistance.

For details regarding the test method precision, see [Annex B](#).

## 5 Apparatus

**5.1 Cutting device**, for cutting the test pieces to the dimensions required.

**5.2 Fluter**, consisting of a pair of matched rotating steel corrugating rolls, a means of heating the rolls and a chute for feeding test pieces squarely between the rolls.

The roll temperature shall be maintained at  $175\text{ °C} \pm 8\text{ °C}$ . The temperature can be controlled by any suitable method. Check the temperature when the rolls are in motion.

One roll is motor-driven at  $4,5\text{ r/min} \pm 1,0\text{ r/min}$  and the rolls are held in mesh by a force of  $100\text{ N} \pm 10\text{ N}$  exerted between the rolls and distributed evenly across the teeth, under test conditions. In some instruments, the force between the rolls is applied by a spring acting in a slide. In such instruments, friction in this device can result in the force which acts upon the test piece being considerably less than the force required to displace the rolls initially. When verifying that an instrument conforms to the requirements, it is therefore necessary to measure the force required to just prevent the stationary roll from moving towards the driven roll, from a position about  $200\text{ }\mu\text{m}$  away.

The essential characteristics of each roll are shown in [Table 1](#).

ISO 7263-1:2018  
<https://standards.iteh.ai/catalog/standards/sist/a3830f55-4a44-4c0b-9abb-a3f398c572a1/iso-7263-1-2018>  
**Table 1 — Measurements for A-flute**

Description	A-profile
Roll diameter	$(228,5 \pm 0,5)\text{ mm}$
Roll face width	$\geq 15\text{ mm}$
Number of teeth for full roll	84
Radius of teeth at peak	$(1,5 \pm 0,1)\text{ mm}$
Radius of teeth at base	$(2,0 \pm 0,1)\text{ mm}$
Depth of teeth	$(4,75 \pm 0,05)\text{ mm}$
Distance between teeth (peak to peak around the arc)	$(8,55 \pm 0,05)\text{ mm}$

In order to optimize the matching of pairs of rolls, pairs of rolls should be selected in which the differences in dimensions between the two are substantially less than the tolerances shown. A difference of  $0,1\text{ mm}$  or less for the pair of rolls is recommended. Prior to first use, the rolls should be run at the operating temperature for about 6 h with a mild abrasive on the teeth. The two rolls should then be marked in some way so that, after removal for cleaning or maintenance, they can be reassembled with exactly the same teeth in mesh.

NOTE In some fluters, a full roll is not used.

Partial roll fluters may be used, if they meet the geometry described in [Table 1](#).

For maintenance of fluting rolls (horizontal type) see [Annex A](#).



Dimensions in millimetres

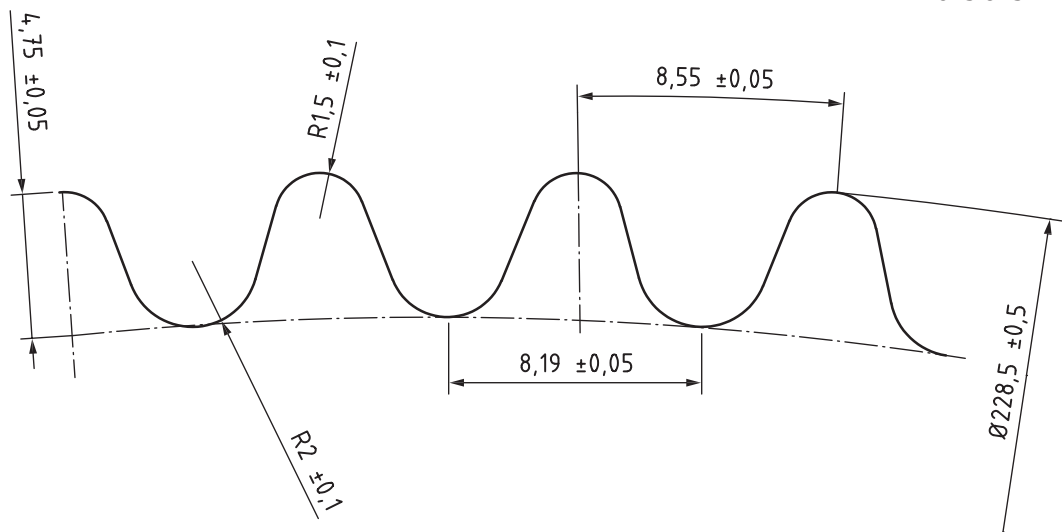

Figure 1 — A-profile of corrugating rolls

### 5.3 Rack and comb.

**5.3.1 Rack**, at least 19 mm wide with a profile corresponding to the teeth of the corrugating rolls.

It has nine full teeth and one incomplete tooth at each end so as to form 10 valleys. The tooth spacing and the height of the teeth correspond to the data in Table 1, Figure 1 and Figure 3.

**5.3.2 Comb**, at least 19 mm wide with 10 prongs (see Figure 2 and Figure 3).

The rack (5.3.1) and comb may be replaced with an automatic device, provided it can be demonstrated that this device will produce the same results. For the comb, a trapezoidal profile is recommended.

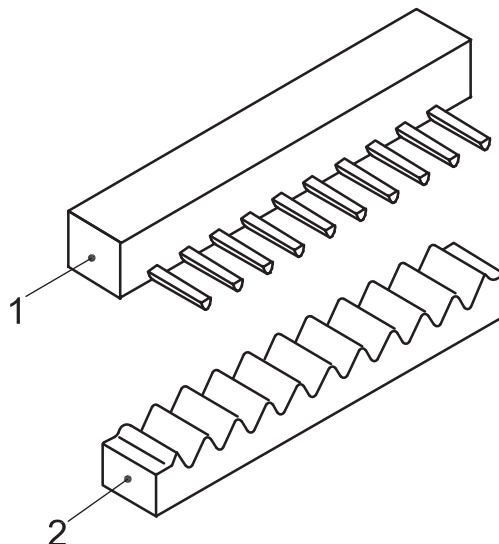

#### Key

- 1 comb
- 2 rack

Figure 2 — Profile of comb and rack

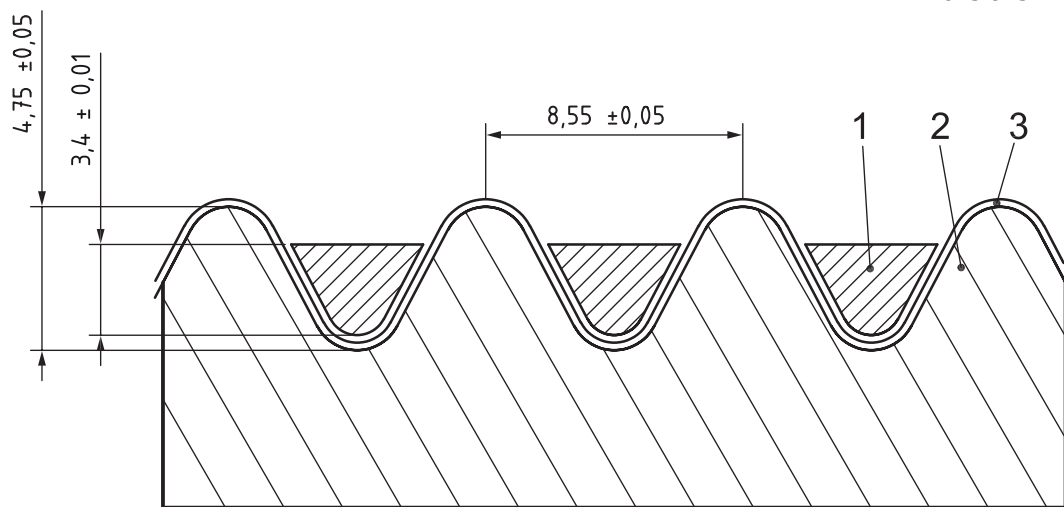
**Key**

- 1 comb
- 2 rack
- 3 paper

**Figure 3 — Dimensions of comb and rack**

**5.4 Pressure-sensitive adhesive tape**, for example Tesafix 4961, Permacell P-50 and 3M grade 410 tape<sup>1)</sup> at least 15 mm wide.

The tape shall be of low stretch and have good adhesion properties; it shall not transfer moisture to the substrate during the test.

**5.5 Flat crush tester**, motor-driven, fixed-platen type in accordance with ISO 13820.

Test shall be conducted with sandpaper (400 grit, see the ISO 6344 series<sup>[5]</sup>) on the platens. The test appliance shall be operated with a compression rate of 12,5 mm/min. Any deviation from this shall be specified in the report.

**6 Sampling**

If the tests are being made to evaluate a lot, the sample shall be selected in accordance with ISO 186. If the tests are made on another type of sample, make sure that the specimens taken are representative of the sample received.

**7 Conditioning**

Condition the sample in accordance with ISO 187.

**8 Preparation of test pieces**

If the determination of the flat crush resistance index is required, the grammage of the conditioned sample shall be tested according to ISO 536. Test pieces shall be free from wrinkles, creases and other visible defects.

1) Tesafix 4961, Permacell P-50 and 3M grade 410 tape are examples of suitable products available commercially. This information is given for the convenience of users of this document and does not constitute an endorsement by ISO of these products.

Cut at least 10 test pieces with a width of  $12,7 \text{ mm} \pm 0,1 \text{ mm}$  and a length of 150 mm to 160 mm.

The length shall be cut in the machine direction. Care should be taken not to damage the edges of the test pieces and they should not be handled more than is necessary.

## 9 Procedure

### 9.1 General

The compression test shall be carried out immediately after fluting (see 9.2) or after reconditioning (see 9.3).

### 9.2 Testing immediately after fluting

If the test is to be carried out immediately after fluting, the total time between discharge of the fluted test piece from the fluting rolls and the initial application of the crushing force shall be 15 s to 25 s. Arrange all equipment to facilitate completing the operations in the specified time, including pre-cutting lengths of the adhesive tape (5.4) that is to serve as the facing to the prescribed length (at least 120 mm long) and adhering one end of each strip lightly to the workbench.

### 9.3 Testing after 30 min of reconditioning

If the test is to be carried out after reconditioning, the composite test piece (i.e. the fluted test piece attached to the adhesive tape) shall be reconditioned for 30 min to 35 min in the conditioning atmosphere used to condition the samples (see Clause 7). If the test is carried out on reconditioned samples, all of the composite test pieces may be formed prior to testing.

### 9.4 Fluting and testing

ISO 7263-1:2018

<https://standards.iteh.ai/catalog/standards/sist/a3830fb5-4a44-4c0b-9abb->

Start the motor and heat the corrugating rolls (5.2) to  $175^{\circ}\text{C} \pm 8^{\circ}\text{C}$ . Taking care that one edge is flat on the guide, feed a test piece into the corrugating rolls with its longer side perpendicular to the nip. When the corrugated test piece emerges from the fluting rolls, place it on the rack (5.3.1) so that approximately equal lengths rest on the flat surfaces at each end of the rack.

Place the comb (5.3.2) over the corrugated test piece and press down so that it is held firmly in the valleys of the rack, ensuring that the test piece is bottomed uniformly in each of the flutes.

**NOTE** A rolling motion of the comb as it is placed on the test piece aids in forming the composite test piece on the rack.

Flatten the ends of the corrugated test piece to facilitate subsequent removal of the test piece from the comb. Next place a strip of the adhesive tape (5.4), at least 120 mm long, adhesive side down, along the tips of the flutes and apply pressure (preferably by means of a flat rigid block) to the tape to adhere it to the tips of the flutes and the test piece ends. Carefully withdraw the comb from the flutes, without damaging the test piece, and lift the resulting 10-flute composite test piece out of the rack. If more than 10 flutes are formed, crush the extra flute(s) by hand prior to testing.

Care shall be taken to avoid distortion of the flutes caused by applying too great a pressure when adhering the tape to the tips of the flutes.

Perform the flat crush tests either immediately or after reconditioning (in the same conditioning atmosphere used to condition the samples).

Place the composite test piece centrally on the lower platen of the crush tester (5.5) with the uncovered flutes upwards. Start the crush tester and determine, to the nearest 1 N, the maximum force registered when completely crushing the flutes.

If the flutes have been pressed sideways during the compression or if they have come away from the tape at any point, reject the results.