



Designation: D5755 – 09

Standard Test Method for Microvacuum Sampling and Indirect Analysis of Dust by Transmission Electron Microscopy for Asbestos Structure Number Surface Loading¹

This standard is issued under the fixed designation D5755; the number immediately following the designation indicates the year of original adoption or, in the case of revision, the year of last revision. A number in parentheses indicates the year of last reapproval. A superscript epsilon (ϵ) indicates an editorial change since the last revision or reapproval.

1. Scope

1.1 This test method covers a procedure to (a) identify asbestos in dust and (b) provide an estimate of the surface loading of asbestos in the sampled dust reported as the number of asbestos structures per unit area of sampled surface.

1.1.1 If an estimate of the asbestos mass is to be determined, the user is referred to Test Method **D5756**.

1.2 This test method describes the equipment and procedures necessary for sampling, by a microvacuum technique, non-airborne dust for levels of asbestos structures. The non-airborne sample is collected inside a standard filter membrane cassette from the sampling of a surface area for dust which may contain asbestos.

1.2.1 This procedure uses a microvacuuming sampling technique. The collection efficiency of this technique is unknown and will vary among substrates. Properties influencing collection efficiency include surface texture, adhesiveness, electrostatic properties and other factors.

1.3 Asbestos identified by transmission electron microscopy (TEM) is based on morphology, selected area electron diffraction (SAED), and energy dispersive X-ray analysis (EDXA). Some information about structure size is also determined.

1.4 This test method is generally applicable for an estimate of the surface loading of asbestos structures starting from approximately 1000 asbestos structures per square centimetre.

1.4.1 The procedure outlined in this test method employs an indirect sample preparation technique. It is intended to disperse aggregated asbestos into fundamental fibrils, fiber bundles, clusters, or matrices that can be more accurately quantified by transmission electron microscopy. However, as with all indirect sample preparation techniques, the asbestos observed for quantification may not represent the physical form of the asbestos as sampled. More specifically, the procedure de-

scribed neither creates nor destroys asbestos, but it may alter the physical form of the mineral fibers.

1.5 The values stated in SI units are to be regarded as the standard. The values given in parentheses are for information only.

1.6 *This standard does not purport to address all of the safety concerns, if any, associated with its use. It is the responsibility of the user of this standard to establish appropriate safety and health practices and determine the applicability of regulatory limitations prior to use.*

2. Referenced Documents

2.1 *ASTM Standards:*²

D1193 Specification for Reagent Water

D3195 Practice for Rotameter Calibration

D3670 Guide for Determination of Precision and Bias of Methods of Committee D22

D5756 Test Method for Microvacuum Sampling and Indirect Analysis of Dust by Transmission Electron Microscopy for Asbestos Mass Surface Loading

D6620 Practice for Asbestos Detection Limit Based on Counts

E177 Practice for Use of the Terms Precision and Bias in ASTM Test Methods

E691 Practice for Conducting an Interlaboratory Study to Determine the Precision of a Test Method

3. Terminology

3.1 *Definitions:*

3.1.1 *asbestiform*—a special type of fibrous habit in which the fibers are separable into thinner fibers and ultimately into fibrils. This habit accounts for greater flexibility and higher tensile strength than other habits of the same mineral. For more information on asbestiform mineralogy, see Refs **(1)**,³ **(2)** and **(3)**.

¹ This test method is under the jurisdiction of ASTM Committee **D22** on Air Quality and is the direct responsibility of Subcommittee **D22.07** on Sampling and Analysis of Asbestos.

Current edition approved Dec. 1, 2009. Published December 2009. Originally approved in 1995. Last previous edition approved in 2003 as D5755 - 03. DOI: 10.1520/D5755-09.

² For referenced ASTM standards, visit the ASTM website, www.astm.org, or contact ASTM Customer Service at service@astm.org. For *Annual Book of ASTM Standards* volume information, refer to the standard's Document Summary page on the ASTM website.

³ The boldface numbers in parentheses refer to the list of references at the end of this test method.

3.1.2 *asbestos*—a collective term that describes a group of naturally occurring, inorganic, highly fibrous, silicate dominated minerals, which are easily separated into long, thin, flexible fibers when crushed or processed.

3.1.2.1 *Discussion*—Included in the definition are the asbestiform varieties of: serpentine (chrysotile); riebeckite (crocidolite); grunerite (grunerite asbestos); anthophyllite (anthophyllite asbestos); tremolite (tremolite asbestos); and actinolite (actinolite asbestos). The amphibole mineral compositions are defined according to nomenclature of the International Mineralogical Association (3).

Asbestos	Chemical Abstract Service No. ⁴
Chrysotile	12001-29-5
Crocidolite	12001-28-4
Grunerite Asbestos	12172-73-5
Anthophyllite Asbestos	77536-67-5
Tremolite Asbestos	77536-68-6
Actinolite Asbestos	77536-66-4

3.1.3 *fibril*—a single fiber that cannot be separated into smaller components without losing its fibrous properties or appearance.

3.2 Definitions of Terms Specific to This Standard:

3.2.1 *aspect ratio*—the ratio of the length of a fibrous particle to its average width.

3.2.2 *bundle*—a structure composed of three or more fibers in a parallel arrangement with the fibers closer than one fiber diameter to each other.

3.2.3 *cluster*—a structure with fibers in a random arrangement such that all fibers are intermixed and no single fiber is isolated from the group; groupings of fibers must have more than two points touching.

3.2.4 *debris*—materials that are of an amount and size (particles greater than 1 mm in diameter) that can be visually identified as to their source.

3.2.5 *dust*—any material composed of particles in a size range of <1 mm.

3.2.6 *fiber*—a structure having a minimum length of 0.5 μm , an aspect ratio of 5:1 or greater, and substantially parallel sides (4).

3.2.7 *fibrous*—of a mineral composed of parallel, radiating, or interlaced aggregates of fibers, from which the fibers are sometimes separable. That is, the crystalline aggregate may be referred to as fibrous even if it is not composed of separable fibers, but has that distinct appearance. The term fibrous is used in a general mineralogical way to describe aggregates of grains that crystallize in a needle-like habit and appear to be composed of fibers. Fibrous has a much more general meaning than asbestos. While it is correct that all asbestos minerals are fibrous, not all minerals having fibrous habits are asbestos.

3.2.8 *indirect preparation*—a method in which a sample passes through one or more intermediate steps prior to final filtration.

3.2.9 *matrix*—a structure in which one or more fibers, or fiber bundles that are touching, are attached to, or partially

concealed by a single particle or connected group of non-fibrous particles. The exposed fiber must meet the fiber definition (see 3.2.6).

3.2.10 *structures*—a term that is used to categorize all the types of asbestos particles which are recorded during the analysis (such as fibers, bundles, clusters, and matrices). Final results of the test are always expressed in asbestos structures per square centimetre.

4. Summary of Test Method

4.1 The sample is collected by vacuuming a known surface area with a standard 25 or 37 mm air sampling cassette using a plastic tube that is attached to the inlet orifice which acts as a nozzle. The sample is transferred from inside the cassette to an aqueous suspension of known volume. Aliquots of the suspension are then filtered through a membrane. A section of the membrane is prepared and transferred to a TEM grid using the direct transfer method. The asbestiform structures are identified, sized, and counted by TEM, using SAED and EDXA at a magnification of 15 000 to 20 000X.

5. Significance and Use

5.1 This microvacuum sampling and indirect analysis method is used for the general testing of non-airborne dust samples for asbestos. It is used to assist in the evaluation of dust that may be found on surfaces in buildings such as ceiling tiles, shelving, electrical components, duct work, carpet, etc. This test method provides an index of the surface loading of asbestos structures in the dust per unit area analyzed as derived from a quantitative TEM analysis.

5.1.1 This test method does not describe procedures or techniques required to evaluate the safety or habitability of buildings with asbestos-containing materials, or compliance with federal, state, or local regulations or statutes. It is the user's responsibility to make these determinations.

5.1.2 At present, no relationship has been established between asbestos-containing dust as measured by this test method and potential human exposure to airborne asbestos. Accordingly, the users should consider other available information in their interpretation of the data obtained from this test method.

5.2 This definition of dust accepts all particles small enough to pass through a 1 mm (No. 18) screen. Thus, a single, large asbestos containing particle(s) (from the large end of the particle size distribution) dispersed during sample preparation may result in anomalously large asbestos surface loading results in the TEM analyses of that sample. It is, therefore, recommended that multiple independent samples are secured from the same area, and that a minimum of three samples be analyzed by the entire procedure.

6. Interferences

6.1 The following minerals have properties (that is, chemical or crystalline structure) which are very similar to asbestos minerals and may interfere with the analysis by causing a false positive to be recorded during the test. Therefore, literature references for these materials must be maintained in the

⁴ The non-asbestiform variations of the minerals indicated in 5.1.3 have different Chemical Abstract Service (CAS) numbers.

laboratory for comparison to asbestos minerals so that they are not misidentified as asbestos minerals.

- 6.1.1 *Antigorite*.
- 6.1.2 *Palygorskite (Attapulгите)*.
- 6.1.3 *Halloysite*.
- 6.1.4 *Pyroxenes*.
- 6.1.5 *Sepiolite*.
- 6.1.6 *Vermiculite scrolls*.
- 6.1.7 *Fibrous talc*.

6.1.8 Hornblende and other amphiboles other than those listed in 3.1.2.

6.2 Collecting any dust particles greater than 1 mm in size in this test method may cause an interference and, therefore, must be avoided.

7. Materials and Equipment

7.1 *Purity of Reagents*—Reagent grade chemicals shall be used in all tests. Unless otherwise indicated, it is intended that all reagents conform to the specifications of the Committee on Analytical Reagents of the American Chemical Society, where such specifications are available. Other grades may be used, provided it is first ascertained that the reagent is of sufficiently high purity to permit its use without lessening the accuracy of the determination.⁵

7.2 *Transmission Electron Microscope (TEM)*, an 80 to 120 kV TEM, capable of performing electron diffraction, with a fluorescent screen inscribed with calibrated gradations, is required. The TEM must be equipped with energy dispersive X-ray spectroscopy (EDXA) and it must have a scanning transmission electron microscopy (STEM) attachment or be capable of producing a spot size of less than 250 nm in diameter in crossover.

7.3 *Energy Dispersive X-ray System (EDXA)*.

7.4 *High Vacuum Carbon Evaporator*, with rotating stage.

7.5 *High Efficiency Particulate Air (HEPA)*, filtered negative flow hood.

7.6 *Exhaust or Fume Hood*.

7.7 *Particle-free Water* (ASTM Type II, see Specification D1193).

7.8 *Glass Beakers* (50 mL).

7.9 *Glass Sample Containers*, with wide mouth screw cap (200 mL) or equivalent sealable container (height of the glass sample container should be approximately 13 cm high by 6 cm wide).

7.10 *Waterproof Markers*.

7.11 *Forceps* (tweezers).

7.12 *Ultrasonic Bath*, table top model (100 W).

7.13 *Graduated Pipettes* (1, 5, 10 mL sizes), glass or plastic.

7.14 *Filter Funnel*, either 25 mm or 47 mm, glass or disposable. Filter funnel assemblies, either glass or disposable plastic, and using either a 25 mm or 47 mm diameter filter.

7.15 *Side Arm Filter Flask*, 1000 mL.

7.16 *Mixed Cellulose Ester (MCE) Membrane Filters*, 25 or 47 mm diameter, $\leq 0.22 \mu\text{m}$ and $5 \mu\text{m}$ pore size.

7.17 *Polycarbonate (PC) Filters*, 25 or 47 mm diameter, $\leq 0.2 \mu\text{m}$ pore size.

7.18 *Storage Containers*, for the 25 or 47 mm filters (for archiving).

7.19 *Glass Slides*, approximately 76 by 25 mm in size.

7.20 *Scalpel Blades*, No. 10, or equivalent.

7.21 *Cabinet-type Desiccator*, or low temperature drying oven.

7.22 *Chloroform*, reagent grade.

7.23 *Acetone*, reagent grade.

7.24 *Dimethylformamide (DMF)*.

7.25 *Glacial Acetic Acid*.

7.26 *1-methyl-2-pyrrolidone*.

7.27 *Plasma Asher*, low temperature.

7.28 *pH Paper*.

7.29 *Air Sampling Pump*, low volume personal-type, capable of achieving a flow rate of 1 to 5 L/min.

7.30 *Rotameter*.

7.31 *Air Sampling Cassettes*, 25 mm or 37 mm, containing $0.8 \mu\text{m}$ or smaller pore size MCE or PC filters.

7.32 *Cork Borer*, 7 mm.

7.33 *Non-Asbestos Mineral*, references as outlined in 6.1.

7.34 *Asbestos Standards*, as outlined in 3.1.2.

7.35 *Tygon⁶ Tubing*, or equivalent.

7.36 *Small Vacuum Pump*, that can maintain a pressure of 92 kPa.

7.37 *Petri Dishes*, large glass, approximately 90 mm in diameter.

7.38 *Jaffe Washer*, stainless steel or aluminum mesh screen, 30 to 40 mesh, and approximately 75 mm by 50 mm in size.

7.39 *Copper TEM Finder Grids*, 200 mesh.

7.40 *Carbon Evaporator Rods*.

7.41 *Lens Tissue*.

7.42 *Ashless Filter Paper Filters*, 90 mm diameter.

7.43 *Gummed Paper Reinforcement Rings*.

7.44 *Wash Bottles*, plastic.

7.45 *Reagent Alcohol*, HPLC Grade (Fisher A995 or equivalent).

⁵ *Reagent Chemicals, American Chemical Society Specifications*, American Chemical Society, Washington, DC. For suggestions on the testing of reagents not listed by the American Chemical Society, see *Analar Standards for Laboratory Chemicals*, BDH Ltd., Poole, Dorset, U.K., and the *United States Pharmacopeia and National Formulary*, U.S. Pharmaceutical Convention, Inc. (USPC), Rockville, MD.

⁶ Tygon is a registered trademark of the DuPont Co.

7.46 *Opening Mesh Screen*, plastic, 1.0 by 1.0 mm, (Spectra-Mesh #146410 or equivalent).

7.47 *Diffraction Grating Replica*.

8. Sampling Procedure for Microvacuum Technique

8.1 For sampling asbestos-containing dust in either indoor or outdoor environments, commercially available cassettes must be used. Air monitoring cassettes containing 25 mm or 37 mm diameter mixed cellulose ester (MCE) or polycarbonate (PC) filter membranes with a pore size less than or equal to 0.8 μm are required (7.31). The number of samples collected depends upon the specific circumstances of the study.

8.2 Maintain a log of all pertinent sampling information and sampling locations.

8.3 Sampling pumps and flow indicators shall be calibrated using a certified standard apparatus or assembly (see Practice D3195 and 7.29).

8.4 Record all calibration information (5).

8.5 Perform a leak check of the sampling system at each sampling site by activating the pump (7.29) with the closed sampling cassette in line. Any air flow shows that a leak is present that must be eliminated before initiating the sampling operation.

8.6 Attach the sampling cassette to the sampling pump at the outlet side of the cassette with plastic tubing (7.35). The plastic tubing must be long enough in that the sample areas can be reached without interference from the sampling pump. Attach a clean, approximately 25.4 mm long piece of plastic tubing (6.35 mm internal diameter) directly to the inlet orifice. Use this piece of tubing as the sampling nozzle. Cut the sampling end of the tubing at a 45° angle as illustrated in Fig. 1. The exact design of the nozzle is not critical as long as some vacuum break is provided to avoid simply pushing the dust around on the surface with the nozzle rather than vacuuming it into the cassette. The internal diameter of the nozzle and flow rate of the pump may vary as long as the air velocity is 100 (± 10) cm/s. This air velocity calculation is based on an internal sampling tube diameter of 6.35 mm at a flow rate of 2 L/min.

8.7 Measure and determine the sample area of interest. A sample area of 100 cm^2 is vacuumed until there is no visible

dust or particulates matter remaining. Perform a minimum of two orthogonal passes on the surface within a minimum of 2 min of sampling time. Avoid scraping or abrading the surface being sampled. (Do not sample any debris or dust particles greater than 1 mm in diameter (see 4.2).) Smaller or larger areas can be sampled, if needed. For example, some surfaces of interest may have a smaller area than 100 cm^2 . Less dusty surfaces may require vacuuming of larger areas. Unlike air samples, the overloading of the cassettes with dust will not be a problem. As defined in 3.2.5, only dust shall be collected for this analysis.

8.8 At the end of sample collection, invert the cassette so that the nozzle inlet faces up before shutting off the power to the pump. The nozzle is then sealed with a cassette end-plug and the cassette/nozzle taped or appropriately packaged to prevent separation of the nozzle and cassette assembly. A second option is the removal of the nozzle from the cassette, then plugging of the cassette and shipment of the nozzle (also plugged at both ends) sealed in a separate closeable plastic bag. A third option is placing the nozzle inside the cassette for shipment. The nozzle is always saved and rinsed because a significant percentage of the dust drawn from a lightly loaded surface may adhere to the inside walls of the tubing.

8.9 Check that all samples are clearly labeled, that all dust sampling information sheets are completed, and that all pertinent information has been enclosed, in accordance with laboratory quality control practices, before transfer of the samples to the laboratory. Include an unused cassette and nozzle as a field blank.

8.10 Wipe off the exterior surface of the cassettes with disposable wet towels (baby wipes) prior to packaging for shipment.

9. Sample Shipment

9.1 Ship dust samples to an analytical laboratory in a sealed container, but separate from any bulk or air samples. The cassettes must be tightly sealed and packed in a material free of fibers or dust to minimize the potential for contamination. Plastic “bubble pack” is probably the most appropriate material for this purpose.

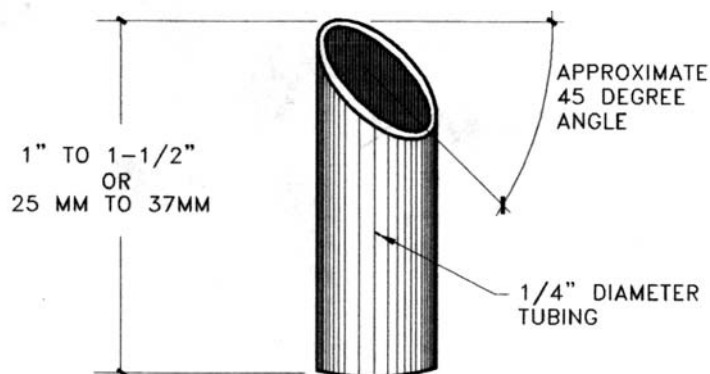

FIG. 1 Example of the Tubing Nozzle

10. Sample Preparation

10.1 Under a negative flow HEPA hood (7.5), carefully wet-wipe the exterior of the cassettes to remove any possible contamination before taking cassettes into a clean preparation area.

10.2 Perform sample preparation in a clean facility that has a separate work area from both the bulk and air sample preparation areas.

10.3 Initial specimen preparation shall take place in a clean HEPA filtered negative pressure hood to avoid any possible contamination of the laboratory or personnel, or both, by the potentially large number of asbestos structures in an asbestos-containing dust sample. Cleanliness of the preparation area hoods is measured by the cumulative process blank surface loadings (see Section 11).

10.4 All sample preparation steps 10.4.1-10.4.6 shall take place in the dust preparation area inside a HEPA hood.

10.4.1 Remove the upper plug from the sample cassette and carefully introduce approximately 10 mL solution of a 50/50 mixture of particle-free water and reagent alcohol into the cassette using a plastic wash bottle (7.44). If the plugged nozzle was left attached to the cassette, then remove the plug and introduce the water/alcohol solution into the cassette through the tubing, and then remove the tubing, if it is visibly clean.

10.4.2 Replace the upper plug or the sample cap and lightly shake the dust solution by hand for 3 s.

10.4.3 Remove the entire cap of the cassette and pour the suspension through a 1.0 by 1.0 mm opening screen (7.46) into a pre-cleaned 200 mL glass specimen bottle (7.9). All visible traces of the sample contained in the cassette shall be rinsed through the screen into the specimen bottle with a plastic wash bottle containing the 50/50 solution of particle-free water and alcohol. Repeat this procedure two additional times for a total of three washings. Next, rinse the nozzle two or three times through the screen into the specimen bottle with the 50/50 mixture of water and alcohol. Typically, the total amount of the 50/50 mixture used in the rinse is 50 to 75 mL. Discard the 1.0 by 1.0 mm screen and bring the volume of suspension in the specimen bottle up to the 100 mL mark on the side of the bottle with particle-free water only.

10.4.4 Adjust the pH of the suspension to 3 to 4 using a 10.0 % solution of acetic acid. Use pH paper for testing. Filter the suspension within 24 h to avoid problems associated with bacterial and fungal growth.

10.4.5 Use either a disposable plastic filtration unit or a glass filtering unit (7.14) for filtration of aliquots of the suspension. The ability of an individual filtration unit to produce a uniform distribution may be tested by the filtration of a colored particulate solution such as diluted India ink (solution of carbon black).

10.4.5.1 If a disposable plastic filtration unit is used, then unwrap a new disposable plastic filter funnel unit (either 25 or 47 mm diameter) and remove the tape around the base of the funnel. Remove the funnel and discard the top filter supplied with the apparatus, retaining the coarse polypropylene support pad in place. Assemble the unit with the adapter and a properly

sized neoprene stopper, and attach the funnel to the 1000 mL side-arm vacuum flask (7.15). Place a 5.0 μ m pore size MCE (backing filter) on the support pad. Wet it with a few mL of particle-free water and place an MCE (7.16) or PC filter (≤ 0.22 μ m pore size) (7.17) on top of the backing filter. Apply a vacuum (7.36), ensuring that the filters are centered and pulled flat without air bubbles. Any irregularities on the filter surface requires the discard of that filter. After the filter has been seated properly, replace the funnel and reseal it with the tape. Return the flask to atmospheric pressure.

10.4.5.2 If a glass filtration unit is used, place a 5 μ m pore size MCE (backing filter) on the glass frit surface. Wet the filter with particle-free water, and place an MCE or PC filter (≤ 0.22 μ m pore size) on top of the backing filter. Apply a vacuum, ensuring that the filters are centered and pulled flat without air bubbles. Replace the filters if any irregularities are seen on the filter surface. Before filtration of each set of sample aliquots, prepare a blank filter by filtration of 50 mL of particle-free water. If aliquots of the same sample are filtered in order of increasing surface loading, the glass filtration unit need not be washed between filtration. After completion of the filtration, do not allow the filtration funnel assembly to dry because contamination is then more difficult to remove. Wash any residual solution from the filtration assembly by holding it under a flow of water, then rub the surface with a clean paper towel soaked in a detergent solution. Repeat the cleaning operation, and then rinse two times in particle-free water.

10.4.6 With the flask at atmospheric pressure, add 20 mL of particle-free water into the funnel. Cover the filter funnel with its plastic cover if the disposable filtering unit is used.

10.4.7 Briefly hand shake (3 s) the capped bottle with the sample suspension, then place it in a tabletop ultrasonic bath (7.12) and sonicate for 3.0 min. Maintain the water level in the sonicator at the same height as the suspension in sample bottle. The ultrasonic bath shall be calibrated as described in 20.5. The ultrasonic bath must be operated at equilibrium temperature. After sonicating, return the sample bottle to the work surface of the HEPA hood. Preparation steps 10.4.8-10.4.14 shall be carried out in this hood.

10.4.8 Shake the suspension lightly by hand for 3 s, then let it rest for 2.0 min to allow large particles to settle to the bottom of the bottle or float to the surface.

10.4.9 Estimate the amount of liquid to be withdrawn to produce an adequate filter preparation. Experience has shown that a light staining of the filter surface will yield a suitable preparation for analysis. Filter at least 1.0 mL, but no more than half the total volume. If after examination in the TEM, the smallest volume measured (1.0 mL) (7.13) yields an over-loaded sample, then perform additional serial dilutions of the suspension. If it is estimated that less than 1.0 mL of suspension has to be filtered because of the density of the suspension, perform a serial dilution.

10.4.9.1 If serial dilutions are required, repeat step 10.4.8 before the serial dilution portion is taken. Do not re-sonicate the original suspension or any serial dilutions. The recommended procedure for a serial dilution is to mix 10 mL of the sample suspension with 90 mL of particle-free water in a clean

sample bottle to obtain a 1:10 serial dilution. Follow good laboratory practices when performing dilutions.

10.4.10 Insert a new disposable pipette halfway into the sample suspension and withdraw a portion. Avoid pipetting any of the large floating or settled particles. Uncover the filter funnel and dispense the mixture from the pipette into the water in the funnel.

10.4.11 Apply vacuum to the flask and draw the mixture through the filter.

10.4.12 Discard the pipette.

10.4.13 Disassemble the filtering unit and carefully remove the sample filter with fine tweezers (7.11). Place the completed sample filter particle side up, into a precleaned, labeled, disposable, plastic petri dish (7.48) or other similar container.

10.4.14 In order to ensure that an optimally-loaded filter is obtained, it is recommended that filters be prepared from several different aliquots of the dust suspension. For this series of filters, it is recommended that the volume of each aliquot of the original suspension be a factor of five higher than the previous one. If the filters are prepared in order of increasing aliquot volume, all of the filters for one sample can be prepared using one plastic disposable filtration unit, or without cleaning of glass filtration equipment between individual filtration. Before withdrawal of each aliquot from the sample, shake the suspension without additional sonification and allow to rest for 2 min.

10.4.15 There are many practical methods for drying MCE filters. The following are two examples that can be used: (1) dry MCE filters for at least 12 h (over desiccant) in an airtight cabinet-type desiccator (7.21); (2) to shorten the drying time (if desired), remove a plug of the damp filter and attach it to a glass slide (7.19) as described in 12.1.2 and 12.1.3. Place the slide with a filter plug or filter plugs (up to eight plugs can be attached to one slide) on a bed of desiccant, in the desiccator for 1 h.

10.4.16 PC filters do not require lengthy drying before preparation, but shall be placed in a desiccator for at least 30 min before preparation.

10.5 Prepare TEM specimens from small sections of each dried filter using the appropriate direct transfer preparation method.

11. Blanks

11.1 Prepare sample blanks that include both a process blank (50 mL of particle-free water) for each set of samples analyzed and one unused filter from each new box of sample filters (MCE or PC) used in the laboratory. If glass filtering units are used, prepare and analyze a process blank each time the filtering unit is cleaned. Blanks will be considered contaminated, if after analysis, they are shown to contain more than 53 asbestos structures per square millimetre. This generally corresponds to three or four asbestos structures found in ten grid openings. The source of the contamination must be found before any further analysis can be performed. Reject samples that were processed along with the contaminated blanks and prepare new samples after the source of the contamination is found.

11.2 Prepare field blanks which are included with sample sets in the same manner as the samples, to test for contamination during the sampling, shipping, handling, and preparation steps of the method.

12. TEM Specimen Preparation of Mixed Cellulose Ester (MCE) Filters

NOTE 1—Use of either the acetone or the dimethylformamide-acetic acid method is acceptable.

12.1 Acetone Fusing Method:

12.1.1 Remove a section (a plug) from any quadrant of the sample and blank filters. Sections can be removed from the filters using a 7 mm cork borer (7.32). The cork borer must be wet wiped after each time a section is removed.

12.1.2 Place the filter section (particle side up) on a clean microscope slide. Affix the filter section to the slide with a gummed page reinforcement (7.43), or other suitable means. Label the slide with a glass scribing tool or permanent marker (7.10).

12.1.3 Prepare a fusing dish from a glass petri dish (7.37) and a metal screen bridge (7.38) with a pad of five to six ashless paper filters (7.42) and place in the bottom of the petri dish (4). Place the screen bridge on top of the pad and saturate the filter pads with acetone. Place the slide on top of the bridge in the petri dish and cover the dish. Wait approximately 5 min for the sample filter to fuse and clear.

12.2 Dimethylformamide-Acetic Acid Method:

12.2.1 Place a drop of clearing solution that consists of 35 % dimethylformamide (DMF), 15 % glacial acetic acid, and 50 % Type II water (v/v) on a clean microscope slide. Gauge the amount used so that the clearing solution just saturates the filter section.

12.2.2 Carefully lay the filter segment, sample surface upward, on top of the solution. Bring the filter and solution together at an angle of about 20° to help exclude air bubbles. Remove any excess clearing solution. Place the slide in an oven or on a hot plate, in a fume hood, at 65 to 70°C for 10 min.

12.3 Plasma etching of the collapsed filter is required.

12.3.1 The microscope slide to which the collapsed filter pieces are attached is placed in a plasma asher (7.27). Because plasma ashers vary greatly in their performance, both from unit to unit and between different positions in the asher chamber, it is difficult to specify the exact conditions that must be used. Insufficient etching will result in a failure to expose embedded fibers, and too much etching may result in the loss of particles from the filter surface. To determine the optimum time for ashing, place an unused 25 mm diameter MCE filter in the center of a glass microscope slide. Position the slide approximately in the center of the asher chamber. Close the chamber and evacuate to a pressure of approximately 40 Pa, while admitting oxygen to the chamber at a rate of 8 to 20 cm³/min. Adjust the tuning of the system so that the intensity of the plasma is maximized. Determine the time required for complete oxidation of the filter. Adjust the system parameters to achieve complete oxidation of the filter in a period of approximately 15 min. For etching of collapsed filters, use these operating parameters for a period of 8 min. For additional