

---

---

**Rough-terrain trucks — Visibility test  
methods and their verification —**

**Part 2:  
Slewing rough-terrain variable-reach  
trucks**

**iTeh STANDARD PREVIEW**  
**(standards.iteh.ai)**  
*Chariots tout-terrain — Méthodes d'essai de la visibilité et leur  
vérification —  
Partie 2: Chariots tout-terrain rotatifs à portée variable*

ISO 18063-2:2021

<https://standards.iteh.ai/catalog/standards/sist/92d1a37f-f4dc-4704-a7cc-859c88291935/iso-18063-2-2021>



**iTeh STANDARD PREVIEW**  
**(standards.iteh.ai)**

ISO 18063-2:2021

<https://standards.iteh.ai/catalog/standards/sist/92d1a37f-f4dc-4704-a7cc-859c88291935/iso-18063-2-2021>



**COPYRIGHT PROTECTED DOCUMENT**

© ISO 2021

All rights reserved. Unless otherwise specified, or required in the context of its implementation, no part of this publication may be reproduced or utilized otherwise in any form or by any means, electronic or mechanical, including photocopying, or posting on the internet or an intranet, without prior written permission. Permission can be requested from either ISO at the address below or ISO's member body in the country of the requester.

ISO copyright office  
CP 401 • Ch. de Blandonnet 8  
CH-1214 Vernier, Geneva  
Phone: +41 22 749 01 11  
Email: [copyright@iso.org](mailto:copyright@iso.org)  
Website: [www.iso.org](http://www.iso.org)

Published in Switzerland

# Contents

	Page
<b>Foreword</b> .....	<b>v</b>
<b>Introduction</b> .....	<b>vi</b>
<b>1 Scope</b> .....	<b>1</b>
<b>2 Normative references</b> .....	<b>1</b>
<b>3 Terms and definitions</b> .....	<b>1</b>
<b>4 Basic dimensions</b> .....	<b>4</b>
4.1 Light bulb spacing dimensions.....	4
4.2 Masking dimensions.....	4
4.3 Reference dimensions for the measurement.....	5
<b>5 Test apparatus</b> .....	<b>5</b>
5.1 Test load.....	5
5.2 Light source apparatus.....	5
5.3 Vertical test object.....	5
5.4 Observation mirror.....	5
<b>6 Truck test configuration</b> .....	<b>6</b>
6.1 Equipment of the truck.....	6
6.2 Openings.....	6
6.3 Position of the truck and load handling attachment.....	6
6.3.1 General.....	6
6.3.2 Test simulating manoeuvring.....	6
6.3.3 Test simulating travel.....	6
6.3.4 Test simulating pick-and-place.....	7
<b>7 Measurement procedure</b> .....	<b>7</b>
7.1 Test-surface marking and truck location on the test surface.....	7
7.2 Positioning of the test apparatus.....	8
7.3 Measurement of the masking.....	8
7.3.1 General.....	8
7.3.2 Measurement in travelling condition.....	8
7.3.3 Measurement in manoeuvring condition.....	9
7.3.4 Measurement in pick-and-place condition.....	11
7.4 Fork arm visibility.....	11
<b>8 Calculation method and computer simulation</b> .....	<b>11</b>
8.1 Calculation method.....	11
8.2 Computer simulation.....	12
<b>9 Evaluation method and performance criteria</b> .....	<b>12</b>
9.1 Visibility performance criteria on sector A.....	12
9.2 Visibility performance criteria for the RB.....	12
9.3 Visibility maskings that exceed the visibility performance criteria with direct view.....	13
9.4 Fork arm visibility criteria.....	13
<b>10 Test reports</b> .....	<b>13</b>
10.1 Truck details.....	13
10.2 Drawing.....	13
<b>11 Information for use</b> .....	<b>13</b>
<b>Annex A (informative) Light bulb spacing dimensions</b> .....	<b>14</b>
<b>Annex B (informative) Performance criteria for indirect visibility devices</b> .....	<b>15</b>
<b>Annex C (informative) Procedure for the determination of maskings at the sector A or the RB</b> .....	<b>16</b>
<b>Annex D (informative) Examples of drawings for the test report</b> .....	<b>18</b>

**iTeh STANDARD PREVIEW**  
**(standards.iteh.ai)**

ISO 18063-2:2021

<https://standards.iteh.ai/catalog/standards/sist/92d1a37f-f4dc-4704-a7cc-859c88291935/iso-18063-2-2021>

## Foreword

ISO (the International Organization for Standardization) is a worldwide federation of national standards bodies (ISO member bodies). The work of preparing International Standards is normally carried out through ISO technical committees. Each member body interested in a subject for which a technical committee has been established has the right to be represented on that committee. International organizations, governmental and non-governmental, in liaison with ISO, also take part in the work. ISO collaborates closely with the International Electrotechnical Commission (IEC) on all matters of electrotechnical standardization.

The procedures used to develop this document and those intended for its further maintenance are described in the ISO/IEC Directives, Part 1. In particular, the different approval criteria needed for the different types of ISO documents should be noted. This document was drafted in accordance with the editorial rules of the ISO/IEC Directives, Part 2 (see [www.iso.org/directives](http://www.iso.org/directives)).

Attention is drawn to the possibility that some of the elements of this document may be the subject of patent rights. ISO shall not be held responsible for identifying any or all such patent rights. Details of any patent rights identified during the development of the document will be in the Introduction and/or on the ISO list of patent declarations received (see [www.iso.org/patents](http://www.iso.org/patents)).

Any trade name used in this document is information given for the convenience of users and does not constitute an endorsement.

For an explanation of the voluntary nature of standards, the meaning of ISO specific terms and expressions related to conformity assessment, as well as information about ISO's adherence to the World Trade Organization (WTO) principles in the Technical Barriers to Trade (TBT) see [www.iso.org/iso/foreword.html](http://www.iso.org/iso/foreword.html).

This document was prepared by Technical Committee ISO/TC 110, *Industrial trucks*, Subcommittee SC 4, *Rough-terrain trucks*, in collaboration with the European Committee for Standardization (CEN) Technical Committee CEN/TC 150 *Industrial Trucks – Safety*, in accordance with the Agreement on technical cooperation between ISO and CEN (Vienna Agreement).

A list of all parts in the ISO 18063 series can be found on the ISO website.

Any feedback or questions on this document should be directed to the user's national standards body. A complete listing of these bodies can be found at [www.iso.org/members.html](http://www.iso.org/members.html).

## Introduction

This document is a type-C standard as stated in ISO 12100.

This document is of relevance, in particular, for the following stakeholder groups representing the market players with regard to machinery safety:

- machine manufacturers (small, medium and large enterprises);
- health and safety bodies (regulators, accident prevention organisations, market surveillance etc.)

Others can be affected by the level of machinery safety achieved with the means of the document by the above-mentioned stakeholder groups:

- machine users/employers (small, medium and large enterprises);
- machine users/employees (e.g. trade unions, organizations for people with special needs);
- service providers, e. g. for maintenance (small, medium and large enterprises);
- consumers (in case of machinery intended for use by consumers).

The above-mentioned stakeholder groups have been given the possibility to participate at the drafting process of this document.

The machinery concerned and the extent to which hazards, hazardous situations or hazardous events are covered are indicated in the Scope of this document.

When requirements of this type-C standard are different from those which are stated in type-A or type-B standards, the requirements of this type-C standard take precedence over the requirements of the other standards for machines that have been designed and built according to the requirements of this type-C standard.” <https://standards.iteh.ai/catalog/standards/sist/92d1a37f-f4dc-4704-a7cc-859c88291935/iso-18063-2-2021>

Acknowledging that, at the time of publication, the requirements included in this document do not represent the state of the art, a transition period of 24 months is permitted after the date of publication, such that manufacturers can develop their products sufficiently to meet the requirements of this standard.

The purpose of this document is to address the operator's visibility in such a manner that the operator can see around the slewing rough-terrain variable-reach truck to enable proper, effective and safe operation that can be quantified in objective engineering terms. This document includes a test method that uses two lights placed at the location of the operator's eyes. The maskings due to the truck, its components and attachments and a standard test load are determined around the truck, starting at a boundary line 1 m away from the smallest rectangle that encompasses the truck out to the visibility test circle. The radius of the circle is 12 m. The method used does not capture all of the aspects of the operator's visibility but provides information to assist in determining the acceptability of visibility from the truck. Criteria are included in this document to provide guidance for designers as to the extent of visibility maskings that are acceptable.

Due to the truck's capability and the intended operation mode of the truck, the test method is divided into 4 tests representing the main utilisation:

- driving between 2 work sites, at high speed: visibility is checked in the front sector of the 12m boundary. Crab steering and 4-wheel steering are not permitted at high speed, so there is no need to check visibility at the sides of the truck, neither at the rear-side;
- pick-and-carry: manoeuvring and slewing at low speed on work site, with possible crab or 4-wheel steering, in both forward and backward direction. The risk is then in close proximity of the truck and visibility is checked at 1 m rectangular boundary all around the truck except for trucks with an operating mass greater than 20 tons or a maximum lift height above 20 m, where the distance is greater than 1 m to the front of the truck;

- pick-and-place: slewing the upper structure at low speed, the truck being on stabilisers (if any) in static position. The risk is in close proximity of the boom and/or the tail. The test can be performed in any position of the upper structure, and this document considers the worst case, i.e. when in forward aligned position. Therefore, visibility is checked at 1 m rectangular boundary except for trucks with an operating mass greater than 20 tons or a maximum lift height above 20 m, where the distance is greater than 1 m to the front of the truck;
- on forks: the market is now offering trucks with long reach (up to 40 m and more). Visibility to the forks is then of high importance to ensure visibility to the overall front size of the truck.

For the eye spacing, adjustments (up to the limits specified in [Tables 1](#) and [2](#)) can be made considering that the operator has the capability to turn their head and move their body torso side to side. The eye spacings used are less than the maximum permitted values based on the ergonomics of the operator. This is done to maintain the current state-of-the-art of trucks.

Standard test loads are carried on devices on the truck during the visibility tests. They are intended to be dimensionally representative of typical loads carried by slewing rough-terrain variable-reach trucks and are used to determine their masking effects and to define representative boom geometry of the truck in normal uses.

The established visibility performance criteria are based on the physical aspects of the human operators and ground personnel using various representative dimensions and the design of trucks that have provided acceptable visibility. To establish the visibility criteria, a combination of the eye spacings and masking widths are used. Multiple maskings in sectors are acceptable where there is adequate spacing between the individual maskings. Where the direct visibility is considered inadequate, additional devices for indirect visibility [mirrors or closed-circuit television cameras (CCTV)], can be used to achieve acceptable visibility. For the rectangular boundary (RB) additional devices for indirect visibility (mirrors or CCTV) are preferred. Other aids (see ISO 16001) can be used exceptionally.

[ISO 18063-2:2021](#)

<https://standards.iteh.ai/catalog/standards/sist/92d1a37f-f4dc-4704-a7cc-859c88291935/iso-18063-2-2021>

**iTeh STANDARD PREVIEW**  
**(standards.iteh.ai)**

ISO 18063-2:2021

<https://standards.iteh.ai/catalog/standards/sist/92d1a37f-f4dc-4704-a7cc-859c88291935/iso-18063-2-2021>



# Rough-terrain trucks — Visibility test methods and their verification —

## Part 2: Slewing rough-terrain variable-reach trucks

### 1 Scope

This document applies to slewing rough-terrain variable-reach trucks (hereinafter referred to as trucks) as defined in ISO 5053-1:2020, 3.22, that have a specific seated operator's position, on the left-hand side of the boom, or centre position (excluding operator position on the right side of the boom).

This document specifies a static test method for determining and evaluating the operator's visibility on a rectangular boundary close around the truck and on a 12 m visibility test circle. Performance requirements for visibility are specified in this document. A calculation method or computer simulation can also be used.

This document does not provide performance requirements for the additional means for indirect visibility.

This document also covers information to be provided by the manufacturer.

### 2 Normative references

ISO 18063-2:2021

The following documents are referred to in the text in such a way that some or all of their content constitutes requirements of this document. For dated references, only the edition cited applies. For undated references, the latest edition of the referenced document (including any amendments) applies.

ISO 5053-1:2020, *Industrial trucks — Vocabulary — Part 1: Types of industrial trucks*

ISO 5353:1995, *Earth-moving machinery, and tractors and machinery for agriculture and forestry — Seat index point*

ISO 12100:2010, *Safety of machinery — General principles for design — Risk assessment and risk reduction*

ISO 10896-2:2016, *Rough-terrain trucks — Safety requirements and verification — Part 2: Slewing trucks*

### 3 Terms and definitions

For the purposes of this document, the terms and definitions given in ISO 12100:2010, ISO 10896-2:2016, ISO 5053-1:2020 and the following apply.

ISO and IEC maintain terminological databases for use in standardization at the following addresses:

- ISO Online browsing platform: available at <https://www.iso.org/obp>
- IEC Electropedia: available at <http://www.electropedia.org/>

#### 3.1

##### test surface

area of compacted earth or firm surface that forms the ground reference plane for the visibility measurements, with a gradient of no more than 3 % in any direction

**3.2  
filament position centre-point  
FPCP**

centre at the midpoint of the line between the light-bulb filaments, located 680 mm above and 20 mm in front of the seat index point (SIP) as described in ISO 5353:1995

Note 1 to entry: See [Figure 1](#).

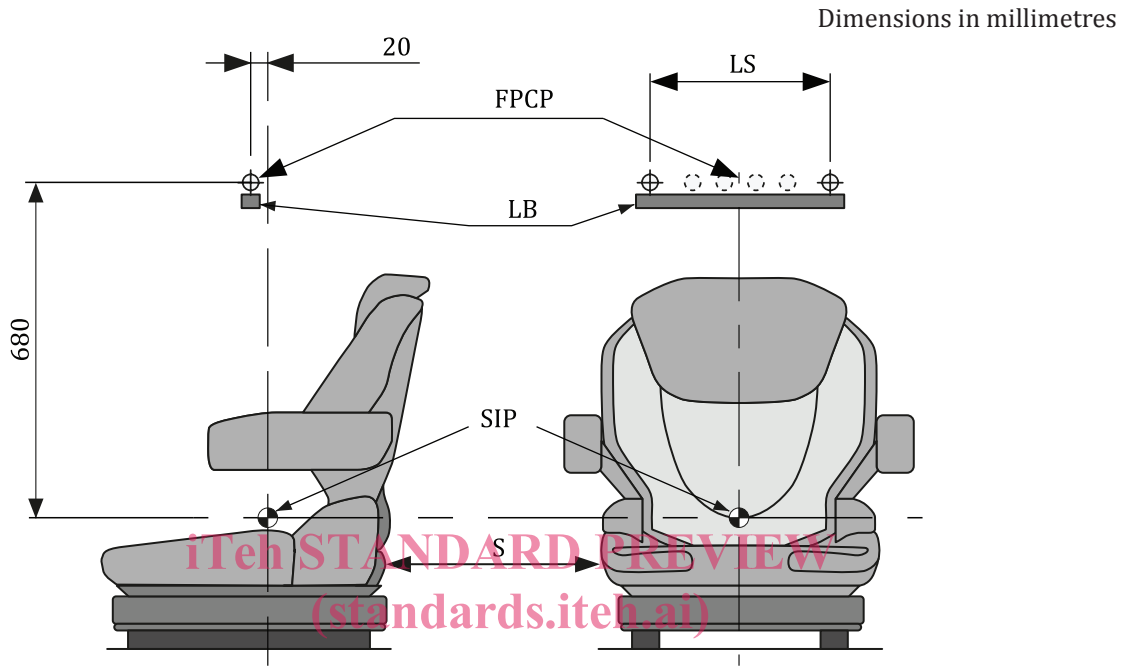

**Key**

- FPCP filament position centre-point
- LB light bar
- LS light bulb spacing
- SIP seat index point
- S seat

ISO 18063-2:2021  
<https://standards.iteh.ai/catalog/standards/sist/92d1a37f-f4dc-4704-a7cc-859c88291935/iso-18063-2-2021>

**Figure 1 — Light source apparatus**

**3.3  
visibility test circle  
VTC**

circle with 12 m radius located on the ground reference plane with its centre vertically below the filament position centre point (3.2)

Note 1 to entry: See [Figure 2](#).

**3.4  
rectangular boundary  
RB**

line on the ground reference plane located at 1 m distance from the test machine boundary (3.5), except for trucks with an operating mass greater than 20 tons or a maximum lift height above 20 m, where the distance is greater than 1 m to the front of the machine

Note 1 to entry: See [Figure 2](#) and [Figure 6](#).

### 3.5 test machine boundary TMB

outermost truck rectangular boundary, the truck being on wheels with stabilizers fully retracted and the upper structure in front aligned position, including forks and excluding mirrors and lighting devices

Note 1 to entry: See [Figure 2](#)

### 3.6 sector A

segment of the visibility test surface to the front of the truck, defined by a 9,5 m chord length for the 12 m radius that is perpendicular to the longitudinal plane passing through the *filament position centre point* ([3.2](#)) with the chord length bisected by the longitudinal plane

Note 1 to entry: See [Figure 2](#).

### 3.7 masking

shadow on *sector A* ([3.6](#)) or on the *rectangular boundary* ([3.4](#)) created because parts of the base truck and/or the *test load* ([3.9](#)) cover the light rays from both of the light bulb filaments

Note 1 to entry: Parts that can cause maskings include, e.g. rollover protective structures (ROPS), window and door frames, exhaust pipes, the engine hood and equipment, such as the boom, the test load

### 3.8 light source apparatus

test unit intended to simulate the position of the operator eyes, and the possible movements of his head

### 3.9 light bulb spacing

distance between the vertical centre axis of the considered light-bulb filaments

Note 1 to entry: Information about light bulb spacing can be found in [Annex A](#).

### 3.10 light bar

rigid support on which the light bulbs are fixed and aligned

### 3.11 visibility performance criteria

criteria for the design of trucks to enable an operator to see objects in the area around the truck during truck operation and specified as maximum allowed *maskings* ([3.4](#)) at the *sector A* ([3.6](#)) or at the *rectangular boundary* ([3.4](#))

### 3.12 test load

simulated load used for the purpose of visibility tests intended to be dimensionally representative of typical loads which might be carried by the truck in normal use

### 3.13 direct visibility

visibility by direct line to the light source

### 3.14 indirect visibility

visibility with the aid of mirrors or with other aids, e.g. close-circuit television (CCTV), fitted to the truck

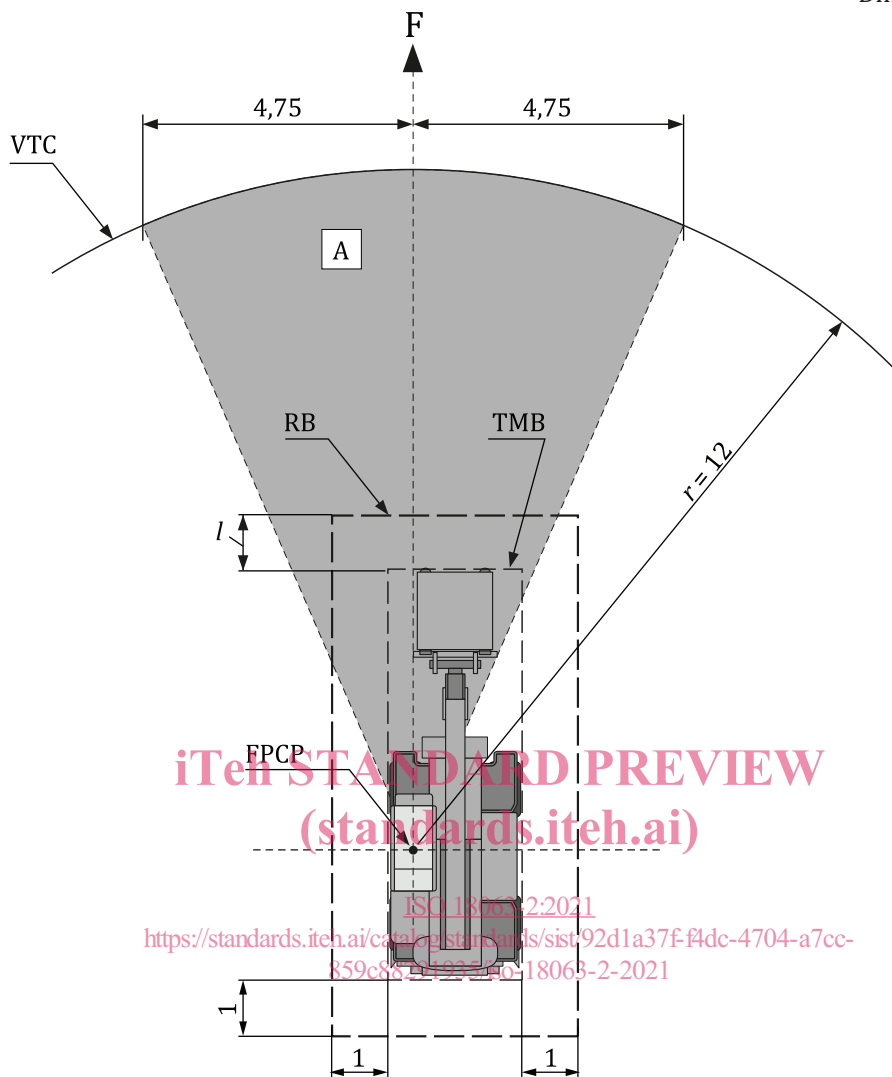

iTech STANDARD PREVIEW  
(standards.iteh.ai)

ISO 18063-2:2021  
<https://standards.iteh.ai/catalog/standards/sist/92d1a37f-f4dc-4704-a7cc-859c8891-832-f6-18063-2-2021>

**Key**

- |   |  |      |                                |
|---|--|------|--------------------------------|
| F | forward direction  | FPCP | filament position centre-point |
| A | sector A   | RB   | rectangular boundary           |
| l | distance from the front of the test load to the rectangular boundary | TMB  | test machine boundary          |
| r | radius of the visibility test circle                                 | VTC  | visibility test circle         |

**Figure 2 — Visibility test circle and rectangular boundary**

**4 Basic dimensions**

**4.1 Light bulb spacing dimensions**

The light bulb spacing shall conform to [Tables 2](#) and [3](#).

**4.2 Masking dimensions**

Maximum masking dimensions for each test are given in [Tables 2](#) and [3](#).