



Designation: D5419 – 09

# Standard Test Method for Environmental Stress Crack Resistance (ESCR) of Threaded Plastic Closures<sup>1</sup>

This standard is issued under the fixed designation D5419; the number immediately following the designation indicates the year of original adoption or, in the case of revision, the year of last revision. A number in parentheses indicates the year of last reapproval. A superscript epsilon ( $\epsilon$ ) indicates an editorial change since the last revision or reapproval.

## 1. Scope\*

1.1 This test method determines the susceptibility of threaded plastic closures to failure due to environmental stress cracking (ESC).

1.2 In use, threaded plastic closures can contact agents that appreciably reduce the stress at which cracks form. Examples of such agents are: soaps, detergents, oils, and liquid bleaches.

1.3 Major factors that influence environmental stress crack resistance (ESCR) of threaded plastic closures include the closure material(s), closure design, molded-in stress, and applied stress.

1.4 This procedure can be applied to all closures, but is particularly applicable to closures made from plastics based on polypropylene (PP) or polystyrene (PS).

1.5 The values stated in SI units are to be regarded as the standard.

1.6 *This standard does not purport to address all of the safety concerns, if any, associated with its use. It is the responsibility of the user of this standard to establish appropriate safety and health practices and determine the applicability of regulatory limitations prior to use.* Specific precautionary statements are given in Section 8 and 6.2.

NOTE 1—There is no known ISO equivalent to this test method.

## 2. Referenced Documents

2.1 *ASTM Standards:*<sup>2</sup>

[D618 Practice for Conditioning Plastics for Testing](#)

[D883 Terminology Relating to Plastics](#)

[D1600 Terminology for Abbreviated Terms Relating to Plastics](#)

<sup>1</sup> This test method is under the jurisdiction of ASTM Committee D20 on Plastics and is the direct responsibility of Subcommittee D20.19 on Film, Sheeting, and Molded Products.

Current edition approved Nov. 15, 2009. Published December 2009. Originally approved in 1993. Last previous edition approved in 2003 as D5419 – 95(2003). DOI: 10.1520/D5419-09.

<sup>2</sup> For referenced ASTM standards, visit the ASTM website, www.astm.org, or contact ASTM Customer Service at service@astm.org. For *Annual Book of ASTM Standards* volume information, refer to the standard's Document Summary page on the ASTM website.

[D2911 Specification for Dimensions and Tolerances for Plastic Bottles](#)

[D3198 Test Method for Application and Removal Torque of Threaded or Lug-Style Closures](#)

[E145 Specification for Gravity-Convection and Forced-Ventilation Ovens](#)

[E691 Practice for Conducting an Interlaboratory Study to Determine the Precision of a Test Method](#)

## 3. Terminology

3.1 *Definitions*—Except for those terms below, see Terminologies [D883](#) and [D1600](#).

3.2 *Definitions of Terms Specific to This Standard:*

3.2.1 *assembly*—closure applied to a bottle finish.

3.2.2 *failure*—during this test, any visible crack.

3.2.2.1 *Discussion*—A crack does not have to penetrate the closure wall to be considered a failure.

3.2.3 *finish*—fixture representing the threaded portion of the bottle.

3.2.4 *threaded closure*—part applied to seal bottle as specified in Specification [D2911](#).

## 4. Summary of Test Method

4.1 This test method consists of applying closures at a specified application torque to rigid finishes (of polysulfone or other appropriate resin), immersing the assembly in a potential stress-cracking agent, and observing and reporting time-to-failure.

## 5. Significance and Use

5.1 This test method compares closures for ESCR. Suitable variables are: closure materials, closure designs, processes, applied torque, and stress-crack agents.

5.2 Results can be used for estimating shelf life of closures in terms of ESCR. This requires that the user has calibrated failure time in this test to failure time in the field for actual packaging systems.

## 6. Apparatus

6.1 *Wide-Mount Gallon Jars*, glass, PET, or other suitable material. Must have lined closures to ensure air-tight seal. Use one jar per sample.

\*A Summary of Changes section appears at the end of this standard

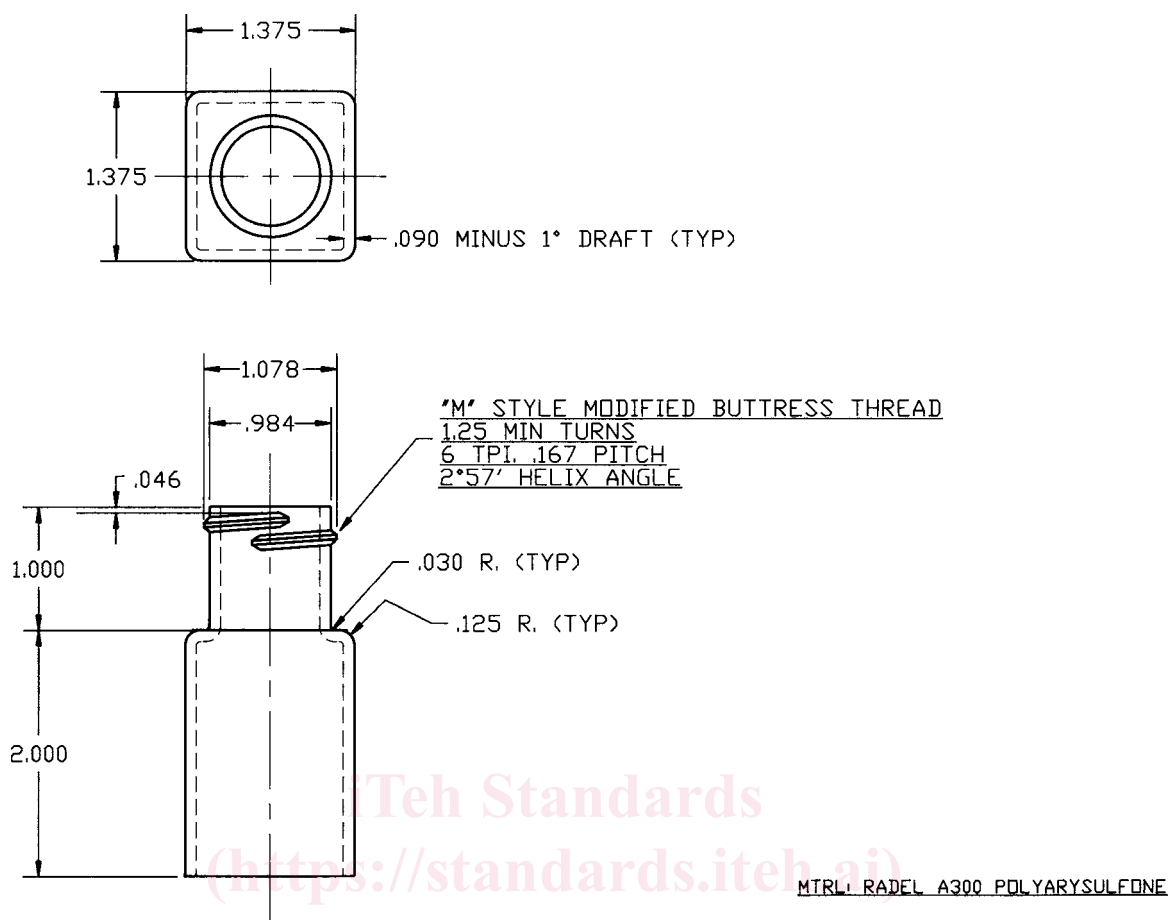

NOTE 1—Tolerances for Dimensions *T*, *E*, and *S* shall be in accordance with Specification D2911.

FIG. 1 Typical Fixture

ASTM D5419-09

6.2 *Circulating-Air Oven*, capable of maintaining a temperature of  $50 \pm 1^\circ\text{C}$  (critical in this application). See Specification E145 for a procedure for confirming satisfactory uniformity of temperature within the oven. There is no air-flow requirement in this application. An environmental room with these properties is also suitable. (**Warning**—A high-temperature safety switch is highly recommended on this oven. Some test liquids can cause extreme pressure to build up upon heating. Under these conditions the test jars may rupture with explosive force. The override cutoff switch should be set to turn off the oven if the test temperature is exceeded by  $10^\circ\text{C}$  or more.)

6.3 *Tongs*, for sample removal and inspection.

6.4 *Bottle Finishes*, polysulfone or other material of equivalent stiffness and thermal coefficient of expansion, to which closures are applied. These can be made by injection molding or by machining rod stock. See Fig. 1 for a drawing of a typical fixture. Use an appropriate size based on closure and bottle specifications.

6.5 *Torque Meter*, with capacity of at least 5 torque Nm, calibrated or verified within the past 12 months.

6.6 *Plastic Test Closures*, lined or unlined closure based on specifications.

NOTE 2—To ensure that full crystallization has essentially been achieved, PP-based closures should condition for at least three weeks before testing and PS closures for at least 16 h.

NOTE 3—To convert lbf-in. torque to Nm torque, multiply by 0.113.

## 7. Reagents and Materials

7.1 *Test Solution*—Use solution for which the closure is intended.

## 8. Hazards

8.1 Always wear protective equipment, such as goggles, gloves, and aprons, appropriate to the product hazard when setting up or inspecting closures.

## 9. Test Specimens

9.1 Normal sample size is 20 closures, typical of lots to be tested. It is strongly advisable to run the test in duplicate (two sets of 20) or to sample more than one lot.

9.2 Visually inspect each closure to be tested. Replace any that appear defective or irregular.

## 10. Conditioning

10.1 *Conditioning*—After aging in accordance with 6.6, condition closures and bottle finishes at  $23 \pm 2^\circ\text{C}$  and  $50 \pm$