



Designation: D5953M – 96(Reapproved 2009)

Standard Test Method for Determination of Non-Methane Organic Compounds (NMOC) in Ambient Air Using Cryogenic Preconcentration and Direct Flame Ionization Detection Method¹

This standard is issued under the fixed designation D5953M; the number immediately following the designation indicates the year of original adoption or, in the case of revision, the year of last revision. A number in parentheses indicates the year of last reapproval. A superscript epsilon (ϵ) indicates an editorial change since the last revision or reapproval.

1. Scope

1.1 This test method² covers a procedure for sampling and determining concentrations of non-methane organic compounds (NMOC) in ambient, indoor, or workplace atmospheres.

1.2 The test method describes the collection of cumulative samples in passivated stainless steel canisters and subsequent laboratory analysis.

1.2.1 This test method describes a procedure for sampling in canisters at final pressures above atmospheric pressure (referred to as pressurized sampling).

1.3 This test method employs a cryogenic trapping procedure for concentration of the NMOC prior to analysis.

1.4 This test method describes the determination of the NMOC by the simple flame ionization detector (FID), without the gas chromatographic columns and complex procedures necessary for species separation.

1.5 The range of this test method is from 20 to 10 000 ppbC (1, 2).³ See for procedures for lowering the range.

1.6 The test method may yield less accurate results for some halogenated or oxygenated hydrocarbons emitted from nearby sources of industrial air pollutants. This is especially true if there are high concentrations of chlorocarbons or chlorofluorocarbons present.

1.7 The values stated in SI units are regarded as standard.

¹ This is under the jurisdiction of ASTM Committee D22 on Air Quality and is the direct responsibility of Subcommittee D22.03 on Ambient Atmospheres and Source Emissions.

Current edition approved Oct. 1, 2009. Published December 2009. Originally approved in 1996. Last previous edition approved in 2001 as D5953M - 96 (2001). DOI: 10.1520/D5953M-96R09.

² This test method is based on EPA Method TO-12: "Determination of Non-Methane Organic Compounds (NMOC) in Ambient Air Using Cryogenic Preconcentration and Direct Flame Ionization Detection (PDFID)", *Compendium of Methods for the Determination of Toxic Organic Compounds in Ambient Air*, EPA 600/4-89-017, U.S. Environmental Protection Agency, Research Triangle Park, NC, March 1990.

³ The boldface numbers in parentheses refer to the list of references at the end of this standard.

1.8 *This standard does not purport to address all of the safety concerns, if any, associated with its use. It is the responsibility of the user of this standard to establish appropriate safety and health practices and determine the applicability of regulatory limitations prior to use.*

2. Referenced Documents

2.1 *ASTM Standards*:⁴

D1193 Specification for Reagent Water

D1356 Terminology Relating to Sampling and Analysis of Atmospheres

D1357 Practice for Planning the Sampling of the Ambient Atmosphere

D5466 Test Method for Determination of Volatile Organic Chemicals in Atmospheres (Canister Sampling Methodology)

3. Terminology

3.1 *Definitions*—For definitions of terms used in this test method, refer to Terminology D1356.

3.2 *Definitions of Terms Specific to This Standard*:

3.2.1 *cryogen*—a refrigerant used to obtain very low temperatures in the cryogenic traps of the analytical system.

3.2.1.1 *Discussion*—Liquid argon (bp – 185.7°C at standard pressure) is recommended for this test method. Cryogenics with lower boiling points, such as liquid nitrogen, should not be used because of possible trapping of oxygen from the sample air, which might lead to the possibility of an explosion or fire. In addition, methane would be trapped.

3.2.2 *dynamic calibration*—calibration of an analytical system with pollutant concentrations that are generated in a dynamic, flowing system, such as by quantitative, flow-rate dilution of a high-concentration gas standard with zero gas.

3.2.3 *NMOC*—non-methane organic compounds.

3.2.3.1 *Discussion*—Total non-methane organic compounds

⁴ For referenced ASTM standards, visit the ASTM website, www.astm.org, or contact ASTM Customer Service at service@astm.org. For *Annual Book of ASTM Standards* volume information, refer to the standard's Document Summary page on the ASTM website.

are those compounds measured by a flame ionization detector, excluding methane and compounds with vapor pressure above 10^{-2} kPa, recovered from the canister.

3.2.4 *ppm C and ppb C*—concentration units of parts per million and parts per billion of organic carbon as detected by the FID.

3.2.4.1 *Discussion*—During calibration with propane, for example, they are equivalent to parts per million by volume (ppm (v)) or parts per billion by volume (ppb (v)), respectively, multiplied by the number of carbon atoms in propane.

4. Summary of Test Method (2-6)

4.1 An air sample is extracted directly from the ambient air, collected in a precleaned sample canister and transported to a laboratory.

4.2 A fixed-volume portion of the sample air is drawn from the canister at a low flow rate through a glass-bead filled trap that is cooled to approximately -186°C with liquid argon. The cryogenic trap simultaneously collects and concentrates the NMOC using condensation, while allowing the nitrogen, oxygen, methane, and other compounds with boiling points below -186°C to pass through the trap without retention. The system is dynamically calibrated so that the volume of sample passing through the trap does not have to be quantitatively measured, but must be precisely repeatable between the calibration and the analytical phases.

4.3 After the fixed-volume air sample has been drawn through the trap, a helium carrier gas flow is diverted to pass through the trap, in the opposite direction to the sample flow, and into an FID. When the residual air and methane have been flushed from the trap and the FID baseline restabilizes, the cryogen is removed and the temperature of the trap is raised to 80 to 90°C .

4.4 The organic compounds previously collected in the trap revolatilize due to the increase in temperature and are carried into the FID, resulting in a response peak or peaks from the FID. The area of the peak or peaks is integrated, and the integrated value is translated to concentration units using a previously obtained calibration curve relating integrated peak areas with known concentrations of propane.

4.5 The cryogenic trap simultaneously concentrates the NMOC while separating and removing the methane from air samples. The technique is thus direct reading using FID for NMOC and, because of the concentration step, it is more sensitive than conventional continuous NMOC analyzers.

4.6 The sample is injected into the hydrogen-rich flame of the FID, where the organic vapors burn, producing ionized molecular fragments. The resulting ion fragments are then collected and detected. Because this test method employs a helium carrier gas, the detector response is nearly identical for many hydrocarbon compounds of interest. Thus, the historical short-coming of varying FID response to aromatic, olefinic, and paraffinic hydrocarbons is minimized. The FID is much less sensitive to most organic compounds containing functional groups such as carbonyls, alcohols, halocarbons, etc.

5. Significance and Use

5.1 Many industrial processes require determination of NMOC in the atmosphere.

5.2 Accurate measurements of ambient concentrations of NMOC are important for the control of photochemical smog because these organic compounds are primary precursors of atmospheric ozone and other oxidants (7, 8).

5.2.1 The NMOC concentrations typically found at urban sites may range up to 1 to 3 ppm C or higher. In order to determine transport of precursors into an area, measurement of NMOC upwind of the area may be necessary. Rural NMOC concentrations originating from areas free from NMOC sources are likely to be less than a few tenths of 1 ppm C.

5.3 Conventional test methods that depend on gas chromatography and qualitative and quantitative species evaluation are excessively difficult and expensive to operate and maintain when speciated measurements are not needed. The test method described here involves a simple, cryogenic preconcentration procedure with subsequent direct detection with the FID. The test method is sensitive and provides accurate measurements of ambient total NMOC concentrations where speciated data are not required.

5.4 An application of the test method is the monitoring of the cleanliness of canisters.

5.5 Another use of the test method is the screening of canister samples prior to analysis.

5.6 Collection of ambient air samples in pressurized canisters provides the following advantages:

5.6.1 Convenient integration of ambient samples over a specific time period,

5.6.2 Capability of remote sampling with subsequent central laboratory analysis,

5.6.3 Ability to ship and store samples, if necessary,

5.6.4 Unattended sample collection,

5.6.5 Analysis of samples from multiple sites with one analytical system,

5.6.6 Collection of replicate samples for assessment of measurement precision, and

5.6.7 Specific hydrocarbon analysis can be performed with the same sample system.

6. Interferences

6.1 In laboratory evaluations, moisture in the sample has been found to cause a positive shift in the FID baseline. The effect of this shift is minimized by carefully selecting the integration termination point and adjusting the baseline used for calculating the area of the NMOC peaks.

6.2 With helium as a carrier gas, FID response is quite uniform for most hydrocarbon compounds, but the response can vary considerably for other types of organic compounds.

7. Apparatus

7.1 *Sample Collection System*, (Fig. 1).

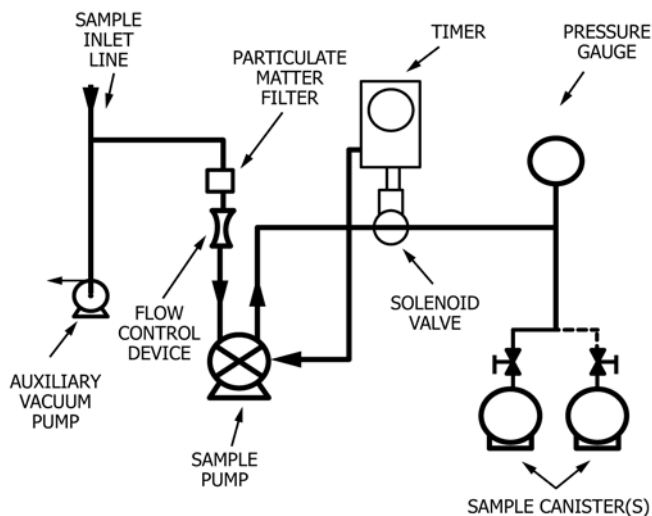

FIG. 1 Sample System for Automatic Collection of Integrated Air Samples

7.1.1 *Sample Canister(s)*, stainless steel, Summa⁵-polished vessel(s) of 4 to 6 L capacity, used for automatic collection of integrated field air samples.

7.1.1.1 Mark each canister with a unique identification number stamped on its frame.

7.1.2 *Sample Pump*, stainless steel, metal bellows type.

7.1.2.1 Ensure that the pump is free of leaks, and uncontaminated by oil or organic compounds.

7.1.2.2 Shock mount the pump to minimize vibration.

7.1.3 *Pressure Gauge*, 0 to 210 kPa (0 to 30 psig).

7.1.4 *Solenoid Valve*, controls the sample flow to the canister with negligible temperature rise.

7.1.5 *Flow Control Device*, mass flowmeter, critical orifice, or short capillary to maintain the sample flow over the sampling period.

7.1.6 *Particulate Matter Filter*, inert in-line filter, 2 μ m or less, or other suitable filter, used to filter the air sample.

7.1.7 *Auxiliary Vacuum Pump or Blower*, draws sample air through the sample inlet line to reduce inlet residence time to no greater than 10 s.

7.1.7.1 Shock mount the pump to minimize vibration.

7.1.8 *Timer*, programmable, and electrically connected to the solenoid valve (7.1.4) and pumps (7.1.2 and 7.1.7), capable of controlling the pumps and the solenoid valve.

7.1.9 *Sample Inlet Line*, transports the sample air into the sample system, consisting of stainless steel tubing components.

7.2 *Sample Canister Cleaning System*, (Fig. 2).

7.2.1 *Vacuum Pump*, capable of evacuating sample canister(s) to an absolute pressure of ≤ 2 Pa (15 μ m Hg).

7.2.2 *Manifold*, stainless steel manifold with connections for simultaneously cleaning several canisters.

7.2.3 *Shut-off Valve(s)*, nine required.

7.2.4 *Pressure Gauge*, 0 to 350 kPa (0 to 50 psig)—monitors zero-air pressure.

7.2.5 *Cryogenic Trap* (2 required), U-shaped open tubular trap cooled with liquid argon used to prevent contamination from back diffusion of oil from vacuum pump, and providing clean, zero-air to the sample canister(s).

7.2.6 *Vacuum Gauge*, capable of measuring vacuum in the manifold to an absolute pressure of 15 Pa (0.1 mm Hg) or less, with scale divisions of 0.1 Pa (0.5 μ m Hg).

7.2.7 *Flow Control Valve*, regulates flow of zero-air into the canister(s).

7.2.8 *Humidifier*, water bubbler or other system capable of providing moisture to the zero-air supply.

7.2.9 *Isothermal Oven*, for heating canisters, not shown in Fig. 2.

7.3 *Analytical System*, (Fig. 3).

7.3.1 *FID System*, includes flow controls for the FID fuel and combustion air, temperature control for the FID, and signal processing electronics. Set the FID combustion air, hydrogen, and helium carrier flow rates as defined by the manufacturer's instructions to obtain an adequate FID response while maintaining a stable flame throughout all phases of the analytical cycle.

7.3.2 *Data Reduction Device*, such as a computer, equipped with data acquisition hardware and software and a laser printer, or an electronic integrator, with chart recorder, capable of integrating the area of one or more FID response peaks and calculating peak area corrected for baseline drift.

7.3.2.1 If a separate integrator and chart recorder are used, exercise care to ensure that these components do not interfere with each other electrically or electronically.

7.3.2.2 Range selector controls on both the integrator and the FID analyzer may not provide accurate range ratios, so prepare individual calibration curves for each range.

7.3.2.3 The integrator must be capable of marking the beginning and ending of peaks, constructing the appropriate baseline between the start and end of the integration period, and calculating the peak area.

7.3.3 *Cryogenic Trap*, constructed from a single piece of chromatographic-grade stainless steel tubing (3 mm outside diameter, 2 mm inside diameter), as shown in Fig. 4.

7.3.3.1 Pack the central portion of the trap (70 to 100 mm) with silanized 180 to 250 μ m (60/80 mesh) glass beads, with small silanized glass wool plugs, to retain the beads.

7.3.3.2 The arms of the trap must be of such length to permit the beaded portion of the trap to be submerged below the level of cryogen in the Dewar flask.

7.3.3.3 Connect the trap directly to the six-port valve (7.3.4) to minimize the line length between the trap (7.3.3) and the FID (7.3.1).

7.3.3.4 Mount the trap to allow clearance so the Dewar flask may be applied and withdrawn to facilitate cooling and heating the trap (see 7.3.12).

7.3.4 *Six-Port Valve*— Locate the six-port valve and as much of the interconnecting tubing as practical inside an oven or otherwise heat it to 80 to 90°C to minimize wall losses or adsorption/desorption in the connecting tubing. All lines must be as short as practical.

⁵ The Summa process is a trademark of Molecetrics, Inc., 4000 E. 89th St., Cleveland, OH 44105.

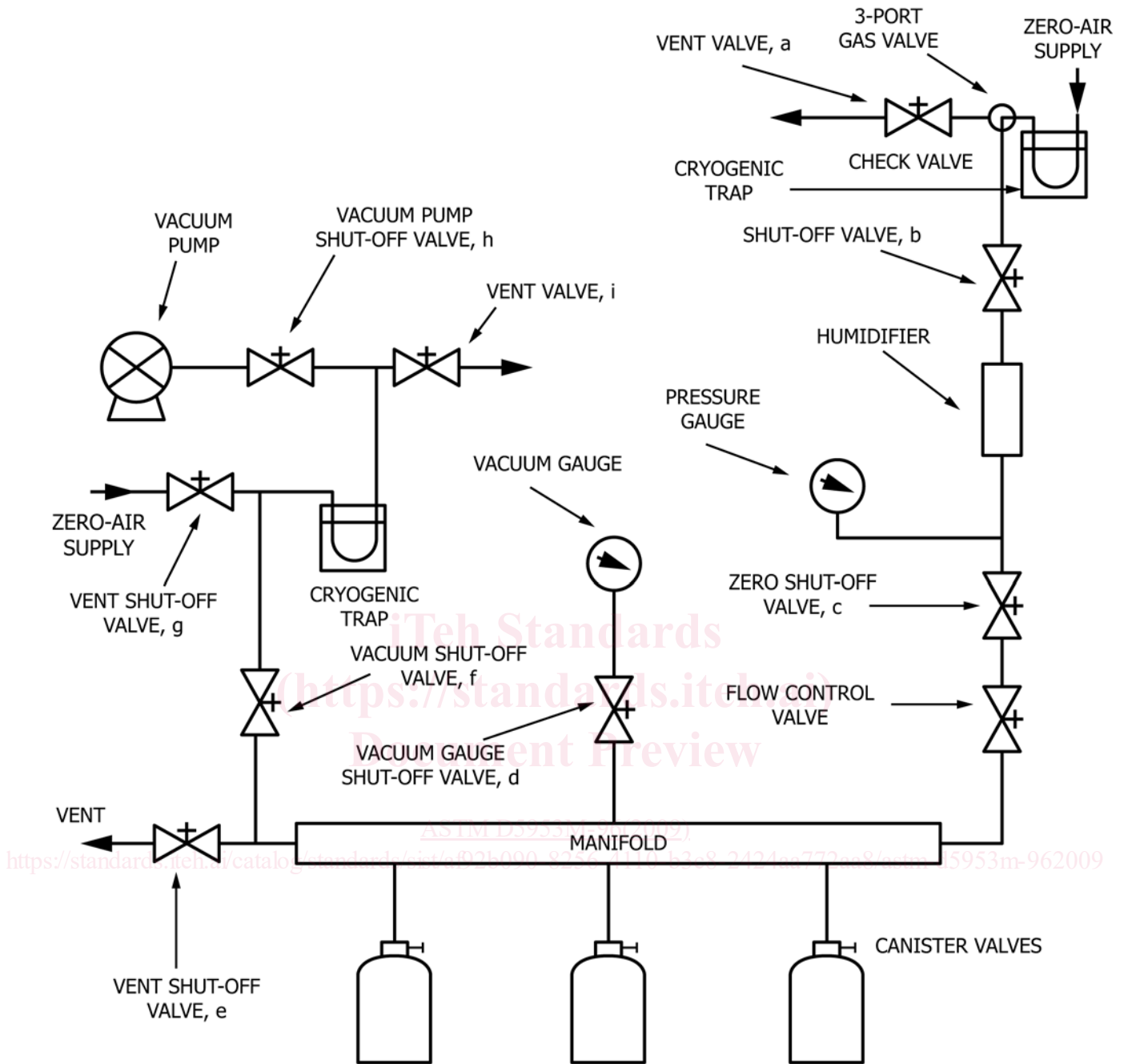

SAMPLE CANISTERS
FIG. 2 Canister Cleaning System

7.3.5 *Multistage Pressure Regulators* (3 required), standard two-stage, stainless steel diaphragm regulators with pressure gauges, for helium, air, and hydrogen cylinders.

7.3.6 *Auxilliary Flow or Pressure Regulators* (2 required), to maintain constant flow rates, within 1 mL/min for the helium carrier and the hydrogen.

7.3.7 *Fine Needle Valve* (2 required)—One adjusts the sample flow rate through the trap, and the other adjusts the sample flow rate from the canister.

7.3.8 *Dewar Flask*, holds cryogen used to cool the trap, sized to contain the submerged portion of the trap.

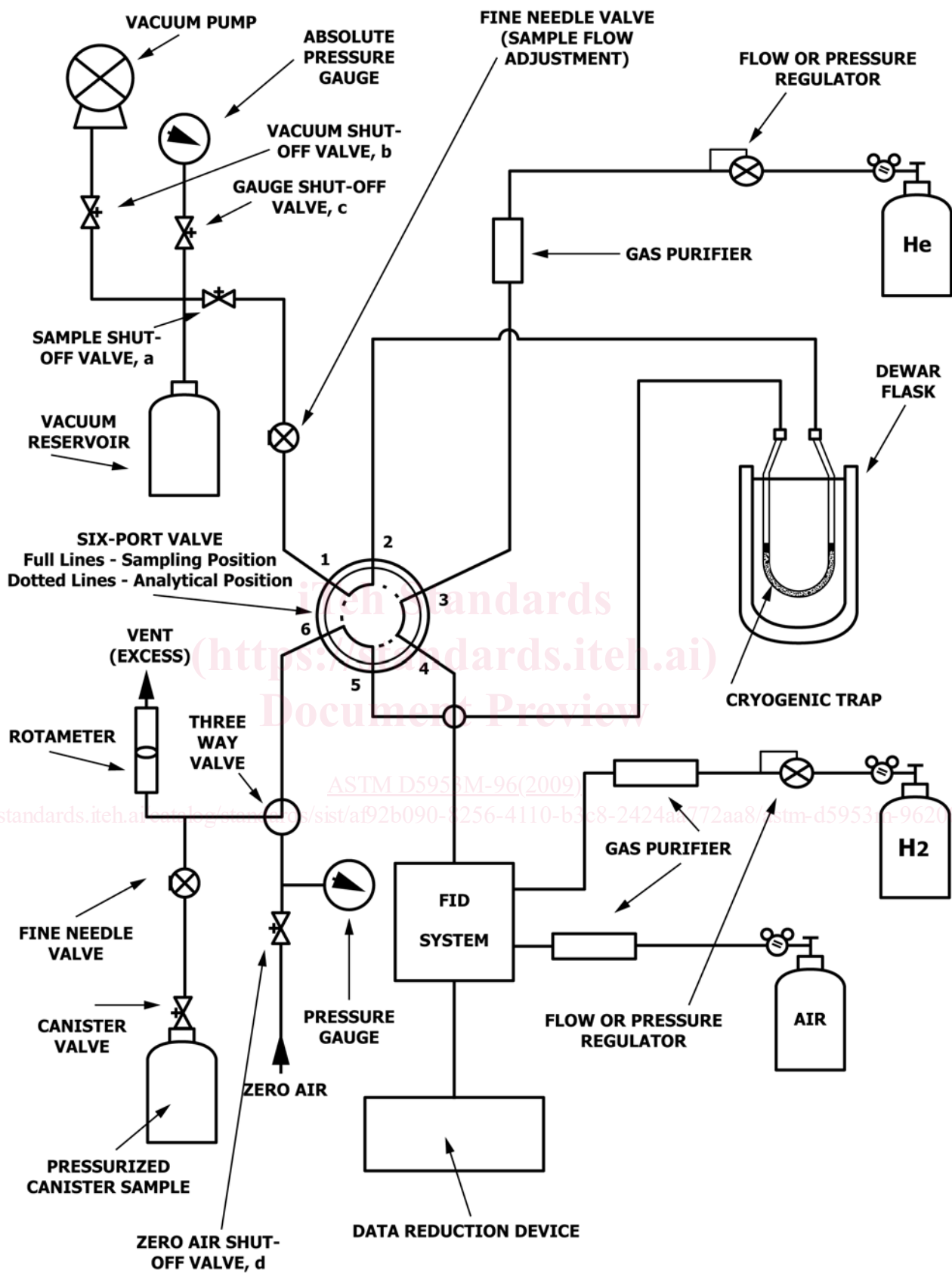

FIG. 3 Analytical System for NMOc

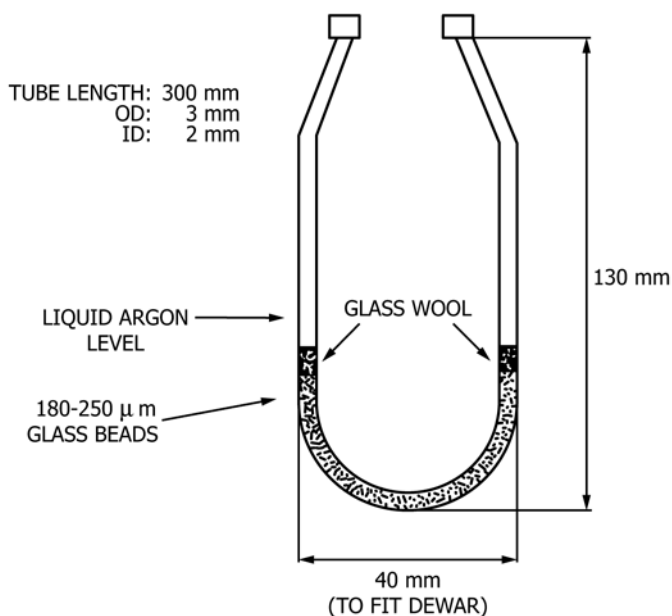

FIG. 4 Cryogenic Sample Trap

7.3.9 *Absolute Pressure Gauge*, 0 to 60 kPa (0 to 450 mm Hg), with scale divisions of 0.25 kPa (2 mm Hg), monitors repeatable volumes of sample air through the cryogenic trap.

7.3.10 *Vacuum Reservoir*; 1 to 2 L capacity, typically 1 L.

7.3.11 *Gas Purifiers* (3 required), gas scrubbers containing Drierite or silica gel and 5A molecular sieve to remove moisture and organic impurities in the helium, air, and hydrogen gas flows.

NOTE 1—Check the purity of the gas purifiers prior to use by passing zero-air through them and analyzing the gas in accordance with 11.4. The gas purifiers are clean if the NMOC concentration of the emitted gas is below the detection limit of the test method.

7.3.12 *Trap Heating System*, chromatographic oven, hot tap water, or other means to heat the trap to 80 to 90°C.

7.3.12.1 A simple heating source for the trap is a beaker or Dewar flask filled with tap water maintained at 80 to 90°C as required for the duration of the test.

7.3.12.2 More repeatable types of heat sources are recommended, including a temperature-programmed chromatograph oven, electrical heating of the trap itself, or any type of heater that brings the temperature of the trap up to 80 to 90°C in 1 to 2 min. This is not shown in Fig. 3.

7.3.13 *Toggle Shut-Off Valves* (4 required), must be leak free. Two are positioned on each side of the vacuum reservoir (7.3.10), one at the absolute pressure gauge (7.3.9), and one at the zero air cylinder (8.4) used for the analytical system leak test (10.1).

7.3.14 *Vacuum Pump*, general purpose laboratory oil-less diaphragm pump must be capable of evacuating the vacuum reservoir (7.3.10) to allow the desired sample volume to be drawn through the trap.

7.3.15 *Vent*, to keep the trap at atmospheric pressure during trapping.

7.3.16 *Rotameter*, verifies the vent flow.

7.3.17 *Three-Way Valve*.

7.3.18 *Chromatographic-Grade Stainless Steel Tubing and Fittings*, stainless steel tubing and fittings for interconnections.

7.3.18.1 All such materials in contact with the sample, analyte, or support gases prior to analysis must be of stainless steel or other inert metal.

7.3.18.2 Do not use plastic or TFE-fluorocarbon tubing or fittings.

7.3.19 *Pressure Gauge*, capable of reading up to 500 kPa (60 psig).

8. Reagents and Materials

8.1 *Gas Cylinders of Helium and Hydrogen*, ultrahigh purity grade.

8.2 *Combustion Air*, cylinder containing less than 0.02 ppm (v) hydrocarbons, or equivalent air source.

8.3 *Propane Calibration Standard*, cylinder containing 1 to 100 ppm (v) (3 to 300 ppm C) propane in air, traceable to a National Institute of Standards and Technology (NIST) Standard Reference Material (SRM) or to a NIST/EPA-approved Certified Reference Material (CRM).

8.4 *Zero-Air*, cylinder containing no more hydrocarbons than the detection limit of the test method.

8.4.1 Zero-air may be obtained from a cylinder of zero-grade compressed air scrubbed with anhydrous calcium sulfate or silica gel and 5A molecular sieve or activated charcoal, or by catalytic cleanup of ambient air.

8.4.2 Pass the zero-air used for canister cleaning (9.3) through the cryogenic cold trap (7.2.5) for final cleanup, then through the hydrocarbon-free water (8.6) humidifier (7.2.8) (or other device).

8.5 *Cryogen* (bp -185.7°C), liquid argon recommended.

8.5.1 If liquid argon cannot maintain the trap temperature at -185.7°C due to the location of the laboratory at high altitudes (where the normal atmospheric pressure is less than 101.3 kPa), a mechanical refrigeration system should be used (see 13.5.1).

8.6 *Purity of Water*— Unless otherwise stated, water shall be Type II reagent water conforming to Specification D1193.

9. Canister Cleanup and Preparation

9.1 Leak test and clean the canisters (7.1.1) of contaminants before sample collection.

9.2 Leak test the canisters by pressurizing them to approximately 200 kPa above atmospheric pressure (30 psig) with zero-air (8.4), using the canister cleaning system (see Fig. 2).

9.2.1 Record the final pressure and close the canister valve, then check the pressure after 24 h. If leak-tight, the pressure will not have not dropped by more than 15 kPa (2 psig) over the 24-h period at constant temperature.

9.2.2 Record the leak check result on the Sampling Data Sheet, Fig. 5.

9.3 Assemble the canister cleaning system, as illustrated in Fig. 2.

9.3.1 Close all the valves.

9.3.2 Add cryogen (8.5) to both the vacuum pump and zero-air supply traps (7.2.5).