**Fasteners — Hexagon head screws,
with fine pitch thread — Product
grades A and B**

*Fixations — Vis à tête hexagonale entièrement filetées, à pas fin —
Grades A et B*

iTeh STANDARD PREVIEW
(standards.iteh.ai)

ISO 8676:2022

<https://standards.iteh.ai/catalog/standards/sist/d405777c-194a-4897-b60b-81e67a70400a/iso-8676-2022>



iTeh STANDARD PREVIEW (standards.iteh.ai)

ISO 8676:2022

<https://standards.iteh.ai/catalog/standards/sist/d405777c-194a-4897-b60b-81e67a70400a/iso-8676-2022>



COPYRIGHT PROTECTED DOCUMENT

© ISO 2022

All rights reserved. Unless otherwise specified, or required in the context of its implementation, no part of this publication may be reproduced or utilized otherwise in any form or by any means, electronic or mechanical, including photocopying, or posting on the internet or an intranet, without prior written permission. Permission can be requested from either ISO at the address below or ISO's member body in the country of the requester.

ISO copyright office
CP 401 • Ch. de Blandonnet 8
CH-1214 Vernier, Geneva
Phone: +41 22 749 01 11
Email: copyright@iso.org
Website: www.iso.org

Published in Switzerland

Contents

Page

Foreword.....	iv
1 Scope.....	1
2 Normative references.....	1
3 Terms and definitions.....	1
4 Dimensions.....	2
5 Requirements and reference International Standards.....	8
6 Marking and labelling.....	9
6.1 Marking on product.....	9
6.2 Labelling on package.....	9
7 Designation.....	9
Annex A (normative) Dimensions for screws 8 mm to 14 mm with product grade B.....	10
Bibliography.....	11

iTeh STANDARD PREVIEW (standards.iteh.ai)

ISO 8676:2022

<https://standards.iteh.ai/catalog/standards/sist/d405777c-194a-4897-b60b-81e67a70400a/iso-8676-2022>

Foreword

ISO (the International Organization for Standardization) is a worldwide federation of national standards bodies (ISO member bodies). The work of preparing International Standards is normally carried out through ISO technical committees. Each member body interested in a subject for which a technical committee has been established has the right to be represented on that committee. International organizations, governmental and non-governmental, in liaison with ISO, also take part in the work. ISO collaborates closely with the International Electrotechnical Commission (IEC) on all matters of electrotechnical standardization.

The procedures used to develop this document and those intended for its further maintenance are described in the ISO/IEC Directives, Part 1. In particular, the different approval criteria needed for the different types of ISO documents should be noted. This document was drafted in accordance with the editorial rules of the ISO/IEC Directives, Part 2 (see www.iso.org/directives).

Attention is drawn to the possibility that some of the elements of this document may be the subject of patent rights. ISO shall not be held responsible for identifying any or all such patent rights. Details of any patent rights identified during the development of the document will be in the Introduction and/or on the ISO list of patent declarations received (see www.iso.org/patents).

Any trade name used in this document is information given for the convenience of users and does not constitute an endorsement.

For an explanation of the voluntary nature of standards, the meaning of ISO specific terms and expressions related to conformity assessment, as well as information about ISO's adherence to the World Trade Organization (WTO) principles in the Technical Barriers to Trade (TBT), see www.iso.org/iso/foreword.html.

This document was prepared by Technical Committee ISO/TC 2, *Fasteners*, Subcommittee SC 11, *Fasteners with metric external thread*, in collaboration with the European Committee for Standardization (CEN) Technical Committee CEN/TC 185, *Fasteners*, in accordance with the Agreement on technical cooperation between ISO and CEN (Vienna Agreement).

This fourth edition cancels and replaces the third edition (ISO 8676:2011), which has been technically revised.

The main changes are as follows:

- tables for dimensions have been entirely restructured, so that the user can find the specified values in a reliable manner (no risk of picking the wrong dimension), see [Clause 4](#) and [Annex A](#);
- the rules for the shortest and greatest standard lengths have been added, and they have been amended accordingly (shortest lengths erroneously published with $l_{\text{nom}} = 40$ mm in the version of 2011 have been restored for M22×2, M30×2 and M36×3); standard greatest lengths have been limited to 200 mm (longer lengths are to be agreed between the purchaser and the manufacturer);
- for steel screws, property class 5.6 has been deleted and property class 12.9/12.9 has been added;
- for stainless steel screws, grades D4 and D6 and property class 80 have been added;
- non-ferrous metal screws have been deleted;
- specifications for marking and labelling have been added as [Clause 6](#).

Any feedback or questions on this document should be directed to the user's national standards body. A complete listing of these bodies can be found at www.iso.org/members.html.

Fasteners — Hexagon head screws, with fine pitch thread — Product grades A and B

1 Scope

This document specifies the characteristics of hexagon head screws, in steel and stainless steel, with metric fine pitch threads M8×1 to M64×4, and with product grades A and B.

If in certain cases other specifications are requested, property classes and stainless steel grades can be selected from ISO 898-1 or ISO 3506-1, and dimensional options from ISO 888 or ISO 4753.

2 Normative references

The following documents are referred to in the text in such a way that some or all of their content constitutes requirements of this document. For dated references, only the edition cited applies. For undated references, the latest edition of the referenced document (including any amendments) applies.

ISO 225, *Fasteners — Bolts, screws, studs and nuts — Symbols and descriptions of dimensions*

ISO 888, *Fasteners — Bolts, screws and studs — Nominal lengths and thread lengths*

ISO 898-1, *Mechanical properties of fasteners made of carbon steel and alloy steel — Part 1: Bolts, screws and studs with specified property classes — Coarse thread and fine pitch thread*

ISO 965-1, *ISO general purpose metric screw threads — Tolerances — Part 1: Principles and basic data*

ISO 1891-4, *Fasteners — Vocabulary — Part 4: Control, inspection, delivery, acceptance and quality*

ISO 3269, *Fasteners — Acceptance inspection*

ISO 3506-1, *Fasteners — Mechanical properties of corrosion-resistant stainless steel fasteners — Part 1: Bolts, screws and studs with specified grades and property classes*

ISO 4042, *Fasteners — Electroplated coating systems*

ISO 4753, *Fasteners — Ends of parts with external ISO metric thread*

ISO 4759-1, *Tolerances for fasteners — Part 1: Bolts, screws, studs and nuts — Product grades A, B and C*

ISO 6157-1, *Fasteners — Surface discontinuities — Part 1: Bolts, screws and studs for general requirements*

ISO 6157-3, *Fasteners — Surface discontinuities — Part 3: Bolts, screws and studs for special requirements*

ISO 8991, *Designation system for fasteners*

ISO 8992, *Fasteners — General requirements for bolts, screws, studs and nuts*

ISO 10683, *Fasteners — Non-electrolytically applied zinc flake coating systems*

3 Terms and definitions

No terms and definitions are listed in this document.

ISO and IEC maintain terminology databases for use in standardization at the following addresses:

— ISO Online browsing platform: available at <https://www.iso.org/obp>

— IEC Electropedia: available at <https://www.electropedia.org/>

4 Dimensions

Dimensions shall be in accordance with [Figures 1](#) and [2](#) and with [Tables 1](#) to [5](#).

Symbols and descriptions of dimensions are defined in ISO 225.

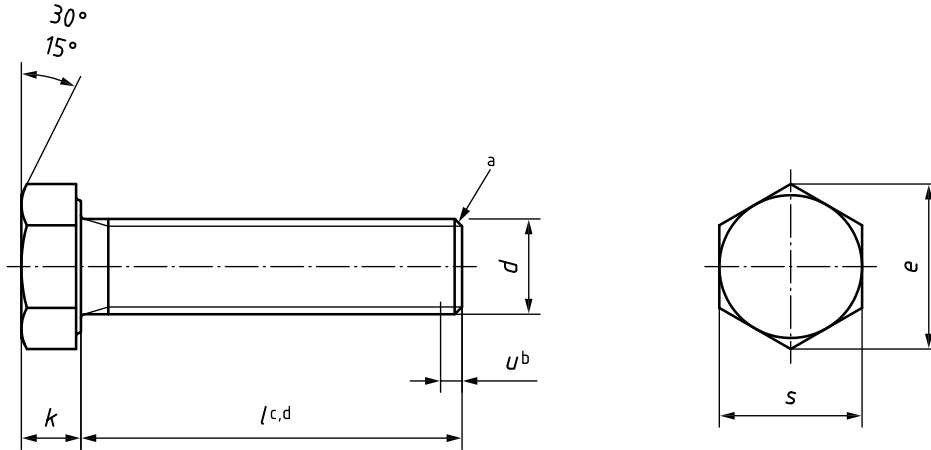

- a Chamfered end (CH) in accordance with ISO 4753.
- b Incomplete thread $u \leq 2P$, where P is the fine pitch thread specified in [Tables 1](#) to [5](#).
- c Shortest standard length l_{nom} determined with $2d$ and rounded (if necessary) to the nearest standard length; shortest standard length $l_{nom} = 120$ mm for thread size 64 mm.
- d Greatest standard length $l_{nom} \leq 10d$ or 200 mm, whichever is the shorter.

Figure 1 — Hexagon head screw

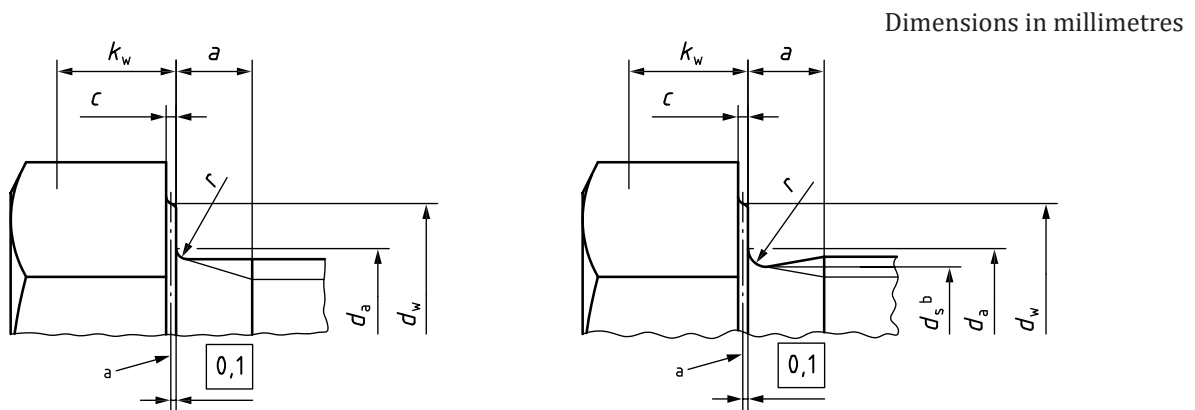

- a Reference datum for d_w .
- b $d_s \approx$ pitch diameter.

Figure 2 — Head details and permissible shapes

Table 1 — Dimensions for product grade A - 8 mm to 16 mm

Dimensions in millimetres

Thread, $d \times P^a$		M8×1	M10×1,25	(M10×1)	M12×1,5	(M12×1,25)	(M14×1,5)	M16×1,5
a^b	max.	3,00	3,75	3,00	4,50	3,75	4,50	4,50
	min.	1,00	1,25	1,00	1,50	1,25	1,50	1,50
c	max.	0,60	0,60	0,60	0,60	0,60	0,60	0,80
	min.	0,15	0,15	0,15	0,15	0,15	0,15	0,20
d_a	max.	9,2	11,2	11,2	13,7	13,7	15,7	17,7
d_w	min.	11,63	14,63	14,63	16,63	16,63	19,64	22,49
e	min.	14,38	17,77	17,77	20,03	20,03	23,36	26,75
k	nom.	5,3	6,4	6,4	7,5	7,5	8,8	10
	max.	5,45	6,58	6,58	7,68	7,68	8,98	10,18
	min.	5,15	6,22	6,22	7,32	7,32	8,62	9,82
k_w	min.	3,61	4,35	4,35	5,12	5,12	6,03	6,87
r	min.	0,4	0,4	0,4	0,6	0,6	0,6	0,6
s	nom. = max.	13,00	16,00	16,00	18,00	18,00	21,00	24,00
	min.	12,73	15,73	15,73	17,73	17,73	20,67	23,67
l		Range of standard lengths between the stepped bold lines						
nom.	min.	max.	Screws with too short lengths					
16	15,65	16,35						
20	19,58	20,42						
25	24,58	25,42						
30	29,58	30,42						
35	34,5	35,5						
40	39,5	40,5						
45	44,5	45,5						
50	49,5	50,5						
55	54,4	55,6						
60	59,4	60,6						
65	64,4	65,6						
70	69,4	70,6						
80	79,4	80,6						
90	89,3	90,7						
100	99,3	100,7						
110	109,3	110,7						
120	119,3	120,7						
130	129,2	130,8						
140	139,2	140,8						
150	149,2	150,8						
> 150			Product grade B in Annex A					c
NOTE Sizes shown in brackets are non-preferred dimensions.								
^a P is the pitch of the thread.								
^b $a_{max} = 3P$ and $a_{min} = 1P$.								
^c Product grade B, see Table 3 .								

Table 2 — Dimensions for product grade A - 18 mm to 24 mm

Dimensions in millimetres

Thread, $d \times P^a$		(M18×2)	(M18×1,5)	M20×2	(M20×1,5)	(M22×2)	(M22×1,5)	M24×2
a^b	max.	6,0	4,5	6,0	4,5	6,0	4,5	6,0
	min.	2,0	1,5	2,0	1,5	2,0	1,5	2,0
c	max.	0,8	0,8	0,8	0,8	0,8	0,8	0,8
	min.	0,2	0,2	0,2	0,2	0,2	0,2	0,2
d_a	max.	20,2	20,2	22,4	22,4	24,4	24,4	26,4
d_w	min.	25,34	25,34	28,19	28,19	31,71	31,71	33,61
e	min.	30,14	30,14	33,53	33,53	37,72	37,72	39,98
k	nom.	11,5	11,5	12,5	12,5	14	14	15
	max.	11,715	11,715	12,715	12,715	14,215	14,215	15,215
	min.	11,285	11,285	12,285	12,285	13,785	13,785	14,785
k_w	min.	7,90	7,90	8,60	8,60	9,65	9,65	10,35
r	min.	0,6	0,6	0,8	0,8	0,8	0,8	0,8
s	nom. = max.	27,00	27,00	30,00	30,00	34,00	34,00	36,00
	min.	26,67	26,67	29,67	29,67	33,38	33,38	35,38
l			Range of standard lengths between the stepped bold lines					
nom.	min.	max.	Screws with too short lengths					
35	34,5	35,5						
40	39,5	40,5						
45	44,5	45,5						
50	49,5	50,5						
55	54,4	55,6						
60	59,4	60,6						
65	64,4	65,6						
70	69,4	70,6						
80	79,4	80,6						
90	89,3	90,7						
100	99,3	100,7						
110	109,3	110,7						
120	119,3	120,7						
130	129,2	130,8						
140	139,2	140,8						
150	149,2	150,8						
> 150			Product grade B in Table 3 or 4					
NOTE Sizes shown in brackets are non-preferred dimensions.								
^a P is the pitch of the thread.								
^b $a_{max} = 3P$ and $a_{min} = 1P$.								

Table 3 — Dimensions for product grade B - 16 mm to 22 mm

Dimensions in millimetres

Thread, $d \times P^a$		M16×1,5	(M18×2)	(M18×1,5)	M20×2	(M20×1,5)	(M22×2)	(M22×1,5)
a^b	max.	4,5	6,0	4,5	6,0	4,5	6,0	4,5
	min.	1,5	2,0	1,5	2,0	1,5	2,0	1,5
c	max.	0,8	0,8	0,8	0,8	0,8	0,8	0,8
	min.	0,2	0,2	0,2	0,2	0,2	0,2	0,2
d_a	max.	17,7	20,2	20,2	22,4	22,4	24,4	24,4
d_w	min.	22,00	24,85	24,85	27,70	27,70	31,35	31,35
e	min.	26,17	29,56	29,56	32,95	32,95	37,29	37,29
k	nom.	10	11,5	11,5	12,5	12,5	14	14
	max.	10,29	11,85	11,85	12,85	12,85	14,35	14,35
	min.	9,71	11,15	11,15	12,15	12,15	13,65	13,65
k_w	min.	6,80	7,81	7,81	8,51	8,51	9,56	9,56
r	min.	0,6	0,6	0,6	0,8	0,8	0,8	0,8
s	nom. = max.	24,00	27,00	27,00	30,00	30,00	34,00	34,00
	min.	23,16	26,16	26,16	29,16	29,16	33,00	33,00
l		Range of standard lengths between the stepped bold lines						
nom.	min.	max.	Product grade A in Table 1 or 2					
≤ 150								
160	158,0	162,0						
180	178,0	182,0						
200	197,7	202,3						
> 200	Length by agreement in accordance with ISO 888						^c	
NOTE Sizes shown in brackets are non-preferred dimensions.								
^a P is the pitch of the thread.								
^b $a_{max} = 3P$ and $a_{min} = 1P$.								
^c Bolts specified in ISO 8765, or screws with length to be agreed between the purchaser and the manufacturer in accordance with ISO 888.								

Table 4 — Dimensions for product grade B - 24 mm to 42 mm

Dimensions in millimetres

Thread, $d \times P^a$		M24×2	(M27×2)	M30×2	(M33×2)	M36×3	(M39×3)	M42×3
a^b	max.	6,0	6,0	6,0	6,0	9,0	9,0	9,0
	min.	2,0	2,0	2,0	2,0	3,0	3,0	3,0
c	max.	0,8	0,8	0,8	0,8	0,8	1,0	1,0
	min.	0,2	0,2	0,2	0,2	0,2	0,3	0,3
d_a	max.	26,4	30,4	33,4	36,4	39,4	42,4	45,6
d_w	min.	33,25	38,00	42,75	46,55	51,11	55,86	59,95
e	min.	39,55	45,20	50,85	55,37	60,79	66,44	71,30
k	nom.	15	17	18,7	21	22,5	25	26
	max.	15,35	17,35	19,12	21,42	22,92	25,42	26,42
	min.	14,65	16,65	18,28	20,58	22,08	24,58	25,58
k_w	min.	10,26	11,66	12,80	14,41	15,46	17,21	17,91
r	min.	0,8	1,0	1,0	1,0	1,0	1,0	1,2
s	nom. = max.	36,00	41,00	46,00	50,00	55,00	60,00	65,00
	min.	35,00	40,00	45,00	49,00	53,80	58,80	63,10
l		Range of standard lengths between the stepped bold lines						
nom.	min.	max.	Product grade A in Table 2 Screws with too short lengths					
55	53,5	56,5						
60	58,5	61,5						
65	63,5	66,5						
70	68,5	71,5						
80	78,5	81,5						
90	88,25	91,75						
100	98,25	101,75						
110	108,25	111,75						
120	118,25	121,75						
130	128,0	132,0						
140	138,0	142,0						
150	148,0	152,0						
160	158,0	162,0						
180	178,0	182,0						
200	197,7	202,3						
> 200	Bolts specified in ISO 8765, or screws with length by agreement in accordance with ISO 888							
NOTE Sizes shown in brackets are non-preferred dimensions.								
^a P is the pitch of the thread.								
^b $a_{max} = 3P$ and $a_{min} = 1P$.								