Elektromotorna ročna orodja, prenosna orodja ter stroji za trato in vrt - Varnost - 4-7. del: Posebne zahteve za ročno upravljane rahljalnike in prezračevalnike travne ruše

Electric motor-operated hand-held tools, transportable tools and lawn and garden machinery - Safety - Part 4-7: Particular requirements for pedestrian controlled walk-behind lawn scarifiers and aerators

Elektrische motorbetriebene handgeführte Werkzeuge, transportable Werkzeuge und Rasen- und Gartenmaschinen - Sicherheit - Teil 4-7: Besondere Anforderungen für personengeführte Rasenvertikutierer und Rasenbelüfter

<https://standards.iteh.ai/catalog/standards/sist/8d55fcba-e553-4572-a837-99b10f8a1a2/sist-en-iec-62841-4-7-2022>

Outils électroportatifs à moteur, outils portables et machines pour jardins et pelouses - Sécurité - Partie 4-7: Exigences particulières pour les scarificateurs à gazon et les aérateurs de gazon à conducteur à pied

Ta slovenski standard je istoveten z: EN IEC 62841-4-7:2022

ICS:

25.140.20	Električna orodja	Electric tools
65.060.70	Vrtnarska oprema	Horticultural equipment

SIST EN IEC 62841-4-7:2022 en

EUROPEAN STANDARD

EN IEC 62841-4-7

NORME EUROPÉENNE

EUROPÄISCHE NORM

September 2022

ICS 25.140.30

English Version

Electric motor-operated hand-held tools, transportable tools and lawn and garden machinery - Safety - Part 4-7: Particular requirements for pedestrian controlled walk-behind lawn scarifiers and aerators
(IEC 62841-4-7:2022)

Outils électroportatifs à moteur, outils portables et machines pour jardins et pelouses - Sécurité - Partie 4-7: Exigences particulières pour les scarificateurs à gazon et les aérateurs de gazon à conducteur à pied
(IEC 62841-4-7:2022)

Elektrische motorbetriebene handgeführte Werkzeuge, transportable Werkzeuge und Rasen- und Gartenmaschinen - Sicherheit - Teil 4-7: Besondere Anforderungen für personengeführte Rasenvertikutierer und Rasenbelüfter
(IEC 62841-4-7:2022)

This European Standard was approved by CENELEC on 2022-08-24. CENELEC members are bound to comply with the CEN/CENELEC Internal Regulations which stipulate the conditions for giving this European Standard the status of a national standard without any alteration.

Up-to-date lists and bibliographical references concerning such national standards may be obtained on application to the CEN-CENELEC Management Centre or to any CENELEC member.

This European Standard exists in three official versions (English, French, German). A version in any other language made by translation under the responsibility of a CENELEC member into its own language and notified to the CEN-CENELEC Management Centre has the same status as the official versions.

CENELEC members are the national electrotechnical committees of Austria, Belgium, Bulgaria, Croatia, Cyprus, the Czech Republic, Denmark, Estonia, Finland, France, Germany, Greece, Hungary, Iceland, Ireland, Italy, Latvia, Lithuania, Luxembourg, Malta, the Netherlands, Norway, Poland, Portugal, Republic of North Macedonia, Romania, Serbia, Slovakia, Slovenia, Spain, Sweden, Switzerland, Türkiye and the United Kingdom.



European Committee for Electrotechnical Standardization
Comité Européen de Normalisation Electrotechnique
Europäisches Komitee für Elektrotechnische Normung

CEN-CENELEC Management Centre: Rue de la Science 23, B-1040 Brussels

EN IEC 62841-4-7:2022 (E)**European foreword**

The text of document 116/589/FDIS, future edition 1 of IEC 62841-4-7, prepared by IEC/TC 116 "Safety of motor-operated electric tools" was submitted to the IEC-CENELEC parallel vote and approved by CENELEC as EN IEC 62841-4-7:2022.

The following dates are fixed:

- latest date by which the document has to be implemented at national (dop) 2023-08-08 level by publication of an identical national standard or by endorsement
- latest date by which the national standards conflicting with the (dow) 2026-08-08 document have to be withdrawn

Attention is drawn to the possibility that some of the elements of this document may be the subject of patent rights. CENELEC shall not be held responsible for identifying any or all such patent rights.

This document has been prepared under a Standardization Request given to CENELEC by the European Commission and the European Free Trade Association, and supports essential requirements of EU Directive(s) / Regulation(s).

For the relationship with EU Directive(s) / Regulation(s), see informative Annex ZZ, which is an integral part of EN IEC 62841-4-7:2022/A11:2022.

Any feedback and questions on this document should be directed to the users' national committee. A complete listing of these bodies can be found on the CENELEC website.

Endorsement notice

<https://standards.iteh.ai/catalog/standards/sist/8d55fcba-e553-4572-a837-99b10f8a1ce2/sist-en-iec-62841-4-7-2022>

The text of the International Standard IEC 62841-4-7:2022 was approved by CENELEC as a European Standard without any modification.

In the official version, for Bibliography, the following note has to be added for the standard indicated:

IEC 62841-4-3 NOTE Harmonized as EN IEC 62841-4-3



INTERNATIONAL STANDARD

NORME INTERNATIONALE

**Electric motor-operated hand-held tools, transportable tools and lawn and garden machinery – Safety –
Part 4-7: Particular requirements for pedestrian controlled walk-behind lawn scarifiers and aerators**

**Outils électroportatifs à moteur, outils portables et machines pour jardins et pelouses – Sécurité –
Partie 4-7: Exigences particulières pour les scarificateurs à gazon et les aérateurs de gazon à conducteur à pied**

INTERNATIONAL
ELECTROTECHNICAL
COMMISSION

COMMISSION
ELECTROTECHNIQUE
INTERNATIONALE

ICS 25.140.30

ISBN 978-2-8322-3961-2

**Warning! Make sure that you obtained this publication from an authorized distributor.
Attention! Veuillez vous assurer que vous avez obtenu cette publication via un distributeur agréé.**

CONTENTS

FOREWORD.....	5
INTRODUCTION.....	7
1 Scope.....	8
2 Normative references	8
3 Terms and definitions	9
4 General requirements	12
5 General conditions for the tests	12
6 Radiation, toxicity and similar hazards.....	12
7 Classification.....	12
8 Marking and instructions.....	13
9 Protection against access to live parts.....	16
10 Starting	16
11 Input and current	17
12 Heating.....	17
13 Resistance to heat and fire	17
14 Moisture resistance	17
15 Resistance to rusting.....	18
16 Overload protection of transformers and associated circuits	19
17 Endurance	19
18 Abnormal operation	19
19 Mechanical hazards.....	20
20 Mechanical strength.....	33
21 Construction.....	34
22 Internal wiring.....	38
23 Components	38
24 Supply connection and external flexible cords	40
25 Terminals for external conductors.....	42
26 Provision for earthing	42
27 Screws and connections.....	42
28 Creepage distances, clearances and distances through insulation.....	42
Annexes	47
Annex I (informative) Measurement of noise and vibration emissions.....	47
Annex K (normative) Battery tools and battery packs	56
Annex L (normative) Battery tools and battery packs provided with mains connection or non-isolated sources.....	71
Annex AA (normative) Product safety labels	75
Annex BB (normative) Test surface.....	80
Annex CC (normative) Lawn scarifier and lawn aerator foot protection test.....	82
Annex DD (normative) Lawn scarifier and lawn aerator tines stopping time test.....	85
Annex EE (informative) Example of a material and construction for fulfilling the requirements for an artificial surface	87
Bibliography.....	89

Figure 101 – Example of a lawn scarifier or a lawn aerator	11
Figure 102 – Operator control zones	23
Figure 103 – Safety distances – single-axle machines	25
Figure 104 – Handle distance – machines with more than one axle.....	26
Figure 105 – Guarding of lawn scarifier and lawn aerator tines, general.....	27
Figure 106 – Guarding of lawn scarifier and lawn aerator tines, side coverage.....	28
Figure 107 – Guarding of lawn scarifier and lawn aerator tines, rear discharge	29
Figure 108 – Guarding of lawn scarifier and lawn aerator tines, front discharge	30
Figure 109 – Thrown object test rig for rear discharge lawn scarifiers and lawn aerators	32
Figure 110 – Strength of tines assembly	34
Figure 111 – Impact test fixture for handle insulation	36
Figure 112 – Test assembly for accessibility of attachment plug blades	41
Figure I.101 – Microphone positions on the hemisphere (see Table I.101)	47
Figure I.102 – Examples of positions of transducers for lawn scarifiers and lawn aerators	54
Figure K.301 – Examples of separable battery pack connection points and direction of applied force.....	65
Figure AA.1 – Product safety labels illustrating – "WARNING – Beware of thrown objects – keep bystanders away"	75
Figure AA.2 – Product safety label illustrating – "WARNING – Keep hands and feet away from the tines"	76
Figure AA.3 – Product safety labels illustrating – "WARNING – Remove plug from mains before maintenance or if cord is damaged"	76
Figure AA.4 – Product safety label illustrating – "WARNING – Keep the supply cord away from the tines"	77
Figure AA.5 – Product safety labels illustrating – "WARNING – Disconnect battery before maintenance"	77
Figure AA.6 – Product safety labels illustrating – "WARNING – Remove the disabling device before maintenance"	78
Figure AA.7 – Product safety labels illustrating – "WARNING – Activate the disabling device before maintenance"	79
Figure BB.1 – Test surface detail	80
Figure BB.2 – Example of test surface, nail plan	81
Figure CC.1 – Foot probe	82
Figure CC.2 – Area to be probed for lawn scarifiers and lawn aerators	84
Figure EE.1 – Sketch of the measurement surface covered with an artificial surface.....	88
Table 4 – Required performance levels	20
Table 9 – Pull and torque value	42
Table 12 – Minimum creepage distances and clearances	44
Table I.101 – Co-ordinates of microphone positions.....	50
Table I.102 – Values of the constant a	50
Table I.103 – Absorption coefficients	50
Table 4 – Required performance levels	61
Table K.301 – Pull and torque value	67

Table K.1 – Minimum creepage distances and clearances between parts of different potential.....	69
Table K.2 – Minimum total sum of creepage distances and clearances to accessible surfaces.....	70

iTeh STANDARD PREVIEW (standards.iteh.ai)

[SIST EN IEC 62841-4-7:2022](https://standards.iteh.ai/catalog/standards/sist/8d55fcba-e553-4572-a837-99b10f8a1ce2/sist-en-iec-62841-4-7-2022)

<https://standards.iteh.ai/catalog/standards/sist/8d55fcba-e553-4572-a837-99b10f8a1ce2/sist-en-iec-62841-4-7-2022>

INTERNATIONAL ELECTROTECHNICAL COMMISSION

—————

**ELECTRIC MOTOR-OPERATED HAND-HELD TOOLS,
TRANSPORTABLE TOOLS AND LAWN AND GARDEN
MACHINERY – SAFETY –**

**Part 4-7: Particular requirements for pedestrian controlled
walk-behind lawn scarifiers and aerators**

FOREWORD

- 1) The International Electrotechnical Commission (IEC) is a worldwide organization for standardization comprising all national electrotechnical committees (IEC National Committees). The object of IEC is to promote international co-operation on all questions concerning standardization in the electrical and electronic fields. To this end and in addition to other activities, IEC publishes International Standards, Technical Specifications, Technical Reports, Publicly Available Specifications (PAS) and Guides (hereafter referred to as "IEC Publication(s)"). Their preparation is entrusted to technical committees; any IEC National Committee interested in the subject dealt with may participate in this preparatory work. International, governmental and non-governmental organizations liaising with the IEC also participate in this preparation. IEC collaborates closely with the International Organization for Standardization (ISO) in accordance with conditions determined by agreement between the two organizations.
- 2) The formal decisions or agreements of IEC on technical matters express, as nearly as possible, an international consensus of opinion on the relevant subjects since each technical committee has representation from all interested IEC National Committees.
- 3) IEC Publications have the form of recommendations for international use and are accepted by IEC National Committees in that sense. While all reasonable efforts are made to ensure that the technical content of IEC Publications is accurate, IEC cannot be held responsible for the way in which they are used or for any misinterpretation by any end user.
- 4) In order to promote international uniformity, IEC National Committees undertake to apply IEC Publications transparently to the maximum extent possible in their national and regional publications. Any divergence between any IEC Publication and the corresponding national or regional publication shall be clearly indicated in the latter.
- 5) IEC itself does not provide any attestation of conformity. Independent certification bodies provide conformity assessment services and, in some areas, access to IEC marks of conformity. IEC is not responsible for any services carried out by independent certification bodies.
- 6) All users should ensure that they have the latest edition of this publication.
- 7) No liability shall attach to IEC or its directors, employees, servants or agents including individual experts and members of its technical committees and IEC National Committees for any personal injury, property damage or other damage of any nature whatsoever, whether direct or indirect, or for costs (including legal fees) and expenses arising out of the publication, use of, or reliance upon, this IEC Publication or any other IEC Publications.
- 8) Attention is drawn to the Normative references cited in this publication. Use of the referenced publications is indispensable for the correct application of this publication.
- 9) Attention is drawn to the possibility that some of the elements of this IEC Publication may be the subject of patent rights. IEC shall not be held responsible for identifying any or all such patent rights.

IEC 62841-4-7 has been prepared by IEC technical committee 116: Safety of motor-operated electric tools. It is an International Standard.

The text of this International Standard is based on the following documents:

Draft	Report on voting
116/589/FDIS	116/621/RVD

Full information on the voting for its approval can be found in the report on voting indicated in the above table.

The language used for the development of this International Standard is English.

This document is to be used in conjunction with the first edition of IEC 62841-1 (2014).

This document supplements or modifies the corresponding clauses in IEC 62841-1, so as to convert it into the IEC Standard: Particular requirements for pedestrian controlled walk-behind lawn scarifiers and aerators.

Where a particular subclause of IEC 62841-1 is not mentioned in this document, that subclause applies as far as reasonable. Where this document states "addition", "modification" or "replacement", the relevant text in IEC 62841-1 is to be adapted accordingly.

The following print types are used:

- requirements: in roman type;
- *test specifications: in italic type;*
- notes: in small roman type.

The terms defined in Clause 3 are printed in **bold typeface**.

Subclauses, notes, tables and figures which are additional to those in IEC 62841-1 are numbered starting from 101.

Subclauses, notes, tables and figures in Annex K and Annex L which are additional to those in the main body of this document are numbered starting from 301.

A list of all parts in the IEC 62841 series, published under the general title *Electric motor-operated hand-held tools, transportable tools and lawn and garden machinery – Safety*, can be found on the IEC website.

This document was drafted in accordance with ISO/IEC Directives, Part 2, and developed in accordance with ISO/IEC Directives, Part 1 and ISO/IEC Directives, IEC Supplement, available at www.iec.ch/members_experts/refdocs. The main document types developed by IEC are described in greater detail at www.iec.ch/standardsdev/publications.

The committee has decided that the contents of this document will remain unchanged until the stability date indicated on the IEC website under webstore.iec.ch in the data related to the specific document. At this date, the document will be

- reconfirmed,
- withdrawn,
- replaced by a revised edition, or
- amended.

NOTE The attention of National Committees is drawn to the fact that equipment manufacturers and testing organizations may need a transitional period following publication of a new, amended or revised IEC publication in which to make products in accordance with the new requirements and to equip themselves for conducting new or revised tests.

It is the recommendation of the committee that the content of this publication be adopted for implementation nationally not earlier than 36 months from the date of publication.

INTRODUCTION

The International Electrotechnical Commission (IEC) draws attention to the fact that it is claimed that compliance with this document may involve the use of a patent. IEC takes no position concerning the evidence, validity, and scope of this patent right.

The holder of this patent right has assured IEC that s/he is willing to negotiate licences under reasonable and non-discriminatory terms and conditions with applicants throughout the world. In this respect, the statement of the holder of this patent right is registered with IEC. Information may be obtained from the patent database available at <http://patents.iec.ch>.

Attention is drawn to the possibility that some of the elements of this document may be the subject of patent rights other than those in the patent database. IEC shall not be held responsible for identifying any or all such patent rights.

iTeh STANDARD PREVIEW
(standards.iteh.ai)

[SIST EN IEC 62841-4-7:2022](https://standards.iteh.ai/catalog/standards/sist/8d55fcba-e553-4572-a837-99b10f8a1ce2/sist-en-iec-62841-4-7-2022)

<https://standards.iteh.ai/catalog/standards/sist/8d55fcba-e553-4572-a837-99b10f8a1ce2/sist-en-iec-62841-4-7-2022>

ELECTRIC MOTOR-OPERATED HAND-HELD TOOLS, TRANSPORTABLE TOOLS AND LAWN AND GARDEN MACHINERY – SAFETY –

Part 4-7: Particular requirements for pedestrian controlled walk-behind lawn scarifiers and aerators

1 Scope

IEC 62841-1:2014, Clause 1 is applicable, except as follows:

Addition:

This document applies to pedestrian controlled walk-behind **lawn scarifiers** and **lawn aerators** which are designed for regenerating lawns by combing out materials such as grass, thatch and moss or cutting vertically into the lawn face using

- metallic **tines**; and/or
- rigid non-metallic **tines**

which rotate about a horizontal axis.

This document does not apply to

- pedestrian controlled walk-behind lawnmowers;
- towed/semi-mounted **lawn scarifiers** and **lawn aerators**;
- ride-on machines;
- non-powered **lawn scarifiers** and **lawn aerators**;
- combustion engine powered **lawn scarifiers** and **lawn aerators**;
- plug aerators (corers);
- hybrid and fuel cell powered machines and associated charging systems; and
- garden tractors or their attachments.

NOTE 101 Pedestrian controlled walk-behind lawnmowers are covered by IEC 62841-4-3.

2 Normative references

IEC 62841-1:2014, Clause 2 is applicable, except as follows:

Addition:

IEC 60664-3:2016, *Insulation coordination for equipment within low-voltage systems – Part 3: Use of coating, potting or moulding for protection against pollution*

IEC 60664-4:2005, *Insulation coordination for equipment within low-voltage systems – Part 4: Consideration of high-frequency voltage stress*

IEC 61058-2-6:2018, *Switches for appliances – Part 2-6: Particular requirements for switches used in electric motor-operated hand-held tools, transportable tools and lawn and garden machinery*

IEC 61672-1:2013, *Electroacoustics – Sound level meters – Part 1: Specifications*

IEC 62841-1:2014, *Electric motor-operated hand-held tools, transportable tools and lawn and garden machinery – Safety – Part 1: General requirements*

ISO 354:2003, *Acoustics – Measurement of sound absorption in a reverberation room*

ISO 2758:2014, *Paper – Determination of bursting strength*

ISO 13857:2019, *Safety of machinery – Safety distances to prevent hazard zones being reached by upper and lower limbs*

Replacement:

IEC 61058-1:2016, *Switches for appliances – Part 1: General requirements*

ISO 3744:2010, *Acoustics – Determination of sound power levels and sound energy levels of noise sources using sound pressure – Engineering methods for an essentially free field over a reflecting plane*

ISO 11201:2010, *Acoustics – Noise emitted by machinery and equipment – Determination of emission sound pressure levels at a work station and at other specified positions in an essentially free field over a reflecting plane with negligible environmental corrections*

3 Terms and definitions

IEC 62841-1:2014, Clause 3 is applicable, except as follows:

Addition: <https://standards.iteh.ai/catalog/standards/sist/8d55fcba-e553-4572-a837-99b10f8a1ce2/sist-en-iec-62841-4-7-2022>

3.101 catcher

part or combination of parts, intended to be used with the **lawn scarifier** or **lawn aerator**, which provides a means for collecting material such as grass, thatch, moss or other debris

3.102 cutting width

total width of scarification/aeration measured across the **tines** at 90° to the direction of travel

3.103 discharge chute

extension of the **tines enclosure** from the **discharge opening**, generally used to control the discharge of material from the **tines**

3.104 discharge opening

gap or opening in the **tines enclosure** through which grass, thatch, moss and other debris may be discharged

3.104.1 front discharge

discharge opening for throwing out grass, thatch and moss so that they will be collected in a **catcher** which is located in front of the **tines**

3.104.2**rear discharge**

discharge opening for throwing out grass, thatch and moss so that they will be collected in a **catcher** which is located behind the **tines**

3.105**lawn aerator**

machine equipped with a **tines assembly** which uses the ground to determine the depth of cut, designed for penetrating the lawn surface

Note 101 to entry: See Figure 101.

Note 102 to entry: **Lawn aerators** that are designed to only make shallow cuts or slices in the soil are also known as verticutters.

3.106**lawn scarifier**

machine equipped with a **tines assembly** designed to scratch the surface or earth face

Note 101 to entry: See Figure 101.

Note 102 to entry: **Lawn scarifiers** are also known as lawn rakes and dethatchers.

3.107**maximum speed**

highest steady-state **tines** speed attainable under all conditions of **normal use**, including no-load, when adjusted in accordance with the manufacturer's specifications and/or instructions

Note 101 to entry: The steady-state **tines** speed excludes transients such as overshoot that may occur before attaining a steady-state condition.

3.108**operator control**

device requiring operator actuation to perform specific functions during **normal operation**

3.109**operator presence control**

device that deactivates rotation of the **tines** when the operator's hand(s) is removed from the control

Note 101 to entry: The device typically consists of a combination of a mechanical actuator and other mechanical and electrical components (e.g. tactile switch, relays, load switches or **electronic components**).

3.110**parking brake**

device to prevent a stationary machine from moving

3.111**service brake**

device for decelerating and stopping a machine from its ground travel speed

3.112**tines**

mechanism used to provide the penetrating action or scratching action of the machine

3.113**tines assembly**

tines together with any supporting part(s), which together perform the aerating or scarifying action

3.114**tines enclosure**

part or assembly which provides the protective means around the **tines**

3.115**tines tip circle**

path described by the outermost point of the **tines** as they rotate about their shaft axis

3.116**traction drive**

means (system) used to transmit power from the motor to the ground drive means

3.117**working position**

any depth setting of the **tines** designated by the manufacturer

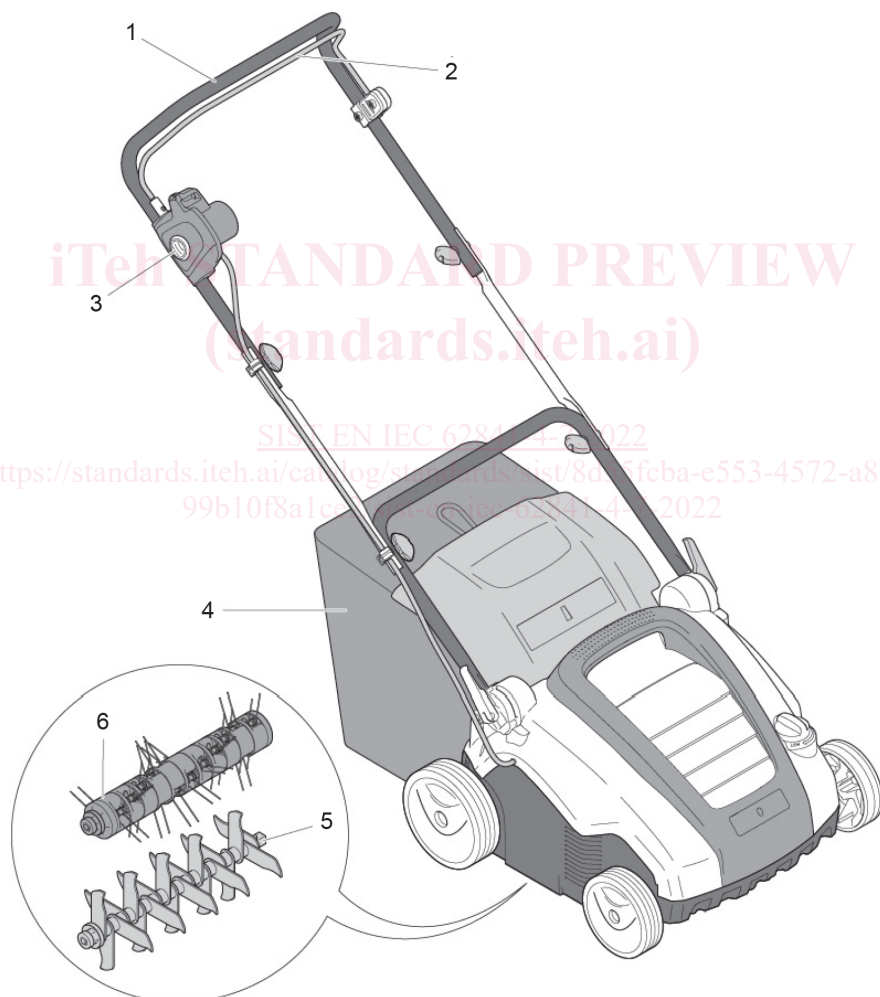

IEC

Key

- 1 handle
- 2 **operator presence control**
- 3 lock-off device
- 4 **catcher**
- 5 **tines assembly** for a lawn aerator
- 6 **tines assembly** for a lawn scarifier

Figure 101 – Example of a lawn scarifier or a lawn aerator