**Buildings and civil engineering
works — Determination of the
staining of porous substrates by
sealants used in joints —**

Part 1:

Test with compression

iTeh STANDARD PREVIEW

(standards.iteh.ai)
*Bâtiments et ouvrages de génie civil — Détermination du tachage des
supports poreux par les mastics utilisés dans les joints —*

Partie 1: Essai avec compression

<https://standards.iteh.ai/catalog/standards/sist/4984a4b3-176d-4975-aa50-03deb802aeba/iso-16938-1-2019>



iTeh STANDARD PREVIEW
(standards.iteh.ai)

ISO 16938-1:2019

<https://standards.iteh.ai/catalog/standards/sist/4984a4b3-176d-4975-aa50-03deb802aeba/iso-16938-1-2019>



COPYRIGHT PROTECTED DOCUMENT

© ISO 2019

All rights reserved. Unless otherwise specified, or required in the context of its implementation, no part of this publication may be reproduced or utilized otherwise in any form or by any means, electronic or mechanical, including photocopying, or posting on the internet or an intranet, without prior written permission. Permission can be requested from either ISO at the address below or ISO's member body in the country of the requester.

ISO copyright office
CP 401 • Ch. de Blandonnet 8
CH-1214 Vernier, Geneva
Phone: +41 22 749 01 11
Fax: +41 22 749 09 47
Email: copyright@iso.org
Website: www.iso.org

Published in Switzerland

Contents

	Page
Foreword.....	iv
1 Scope.....	1
2 Normative references.....	1
3 Terms and definitions.....	1
4 Principle.....	1
5 Apparatus.....	2
5.1 Substrate materials.....	2
5.2 Spacers.....	2
5.3 Non-adherent substrate.....	2
5.4 Masking tape.....	2
5.5 Ventilated convection-type oven.....	2
5.6 Refrigerated enclosure.....	2
5.7 Clamps or other device.....	2
5.8 Actinic radiation accelerated aging apparatus.....	2
5.8.1 General.....	2
5.8.2 Fluorescent ultraviolet radiation/condensation test apparatus.....	2
5.8.3 Xenon light test apparatus.....	3
5.9 Black standard thermometer.....	3
5.10 Measuring device.....	3
6 Preparation of test specimens.....	3
7 Conditioning.....	4
8 Test procedure.....	4
8.1 Compression.....	4
8.2 Aging procedures.....	5
8.2.1 General.....	5
8.2.2 Heat aging.....	5
8.2.3 Cold aging.....	5
8.2.4 Actinic radiation aging.....	5
9 Detection of staining.....	6
9.1 General.....	6
9.2 Detection at the surface of the substrate.....	6
9.3 Detection in the depth of the substrate.....	6
9.4 Expression of results.....	8
10 Test report.....	8

Foreword

ISO (the International Organization for Standardization) is a worldwide federation of national standards bodies (ISO member bodies). The work of preparing International Standards is normally carried out through ISO technical committees. Each member body interested in a subject for which a technical committee has been established has the right to be represented on that committee. International organizations, governmental and non-governmental, in liaison with ISO, also take part in the work. ISO collaborates closely with the International Electrotechnical Commission (IEC) on all matters of electrotechnical standardization.

The procedures used to develop this document and those intended for its further maintenance are described in the ISO/IEC Directives, Part 1. In particular, the different approval criteria needed for the different types of ISO documents should be noted. This document was drafted in accordance with the editorial rules of the ISO/IEC Directives, Part 2 (see www.iso.org/directives).

Attention is drawn to the possibility that some of the elements of this document may be the subject of patent rights. ISO shall not be held responsible for identifying any or all such patent rights. Details of any patent rights identified during the development of the document will be in the Introduction and/or on the ISO list of patent declarations received (see www.iso.org/patents).

Any trade name used in this document is information given for the convenience of users and does not constitute an endorsement.

For an explanation of the voluntary nature of standards, the meaning of ISO specific terms and expressions related to conformity assessment, as well as information about ISO's adherence to the World Trade Organization (WTO) principles in the Technical Barriers to Trade (TBT) see www.iso.org/iso/foreword.html.

This document was prepared by Technical Committee ISO/TC 59, *Buildings and civil engineering works*, Subcommittee SC 8, *Sealants*.

This second edition cancels and replaces the first edition (ISO 16938-1:2008), which has been technically revised.

The main changes compared to the previous edition are as follows:

- the title of the document has been modified;
- the figures have been modified and notes were added to provide further explanation;
- Figure 4 has been replaced by [Table 2](#).

A list of all parts in the ISO 16938 series can be found on the ISO website.

Any feedback or questions on this document should be directed to the user's national standards body. A complete listing of these bodies can be found at www.iso.org/members.html.

Buildings and civil engineering works — Determination of the staining of porous substrates by sealants used in joints —

Part 1: Test with compression

1 Scope

This document specifies a method for determining the staining of porous substrates (e.g. marble, limestone, sandstone or granite) by sealants used in building construction. The method evaluates the likelihood of a sealant causing an early stain on a porous substrate due to exudation of materials from the sealant. The outcome of the test is specific to the tested sealant and tested substrate and cannot be extrapolated to other sealant formulations or other porous substrates. During this accelerated test, if the sealant does not stain or discolour the substrates, it does not mean that the tested sealant will not stain or discolour the tested porous substrate over a longer time period.

2 Normative references

The following documents are referred to in the text in such a way that some or all of their content constitutes requirements of this document. For dated references, only the edition cited applies. For undated references, the latest edition of the referenced document (including any amendments) applies.

ISO 4892-1, *Plastics — Methods of exposure to laboratory light sources — Part 1: General guidance*

ISO 4892-2:2013, *Plastics — Methods of exposure to laboratory light sources — Part 2: Xenon-arc lamps*

ISO 4892-3, *Plastics — Methods of exposure to laboratory light sources — Part 3: Fluorescent UV lamps*

ISO 6927, *Buildings and civil engineering works — Sealants — Vocabulary*

ISO 11431:2002, *Building construction — Jointing products — Determination of adhesion/cohesion properties of sealants after exposure to heat, water and artificial light through glass*

3 Terms and definitions

For the purposes of this document, the terms and definitions given in ISO 6927 apply.

ISO and IEC maintain terminological databases for use in standardization at the following addresses:

— ISO Online browsing platform: available at <https://www.iso.org/obp>

— IEC Electropedia: available at <http://www.electropedia.org/>

4 Principle

This method measures the visible staining attributed to joint sealants on porous substrates that is a result of the conditioning specified.

A sealant is applied and cured between two pieces of porous substrate. The test specimens are compressed and then subjected to heat aging and/or cold aging and/or aging in actinic radiation accelerated weathering equipment. After aging, the test specimens are evaluated and visible staining is

recorded on the exterior surface and in the interior of the substrate after visual inspection of changes in surface appearance and measurements of maximum and minimum stain width and stain penetration.

5 Apparatus

5.1 Substrate materials

For the preparation of each test specimen, two substrate pieces of the same material are required with dimensions as shown in [Figure 1](#).

5.2 Spacers

For the preparation of the test specimens, the spacers shall be of a cross-section 12 mm × 12 mm, with a non-adherent surface (see [Figure 1](#)).

If the spacers are made of a material to which the sealant adheres, their surfaces should be made non-adherent, e.g. by a thin wax coating.

5.3 Non-adherent substrate

For the preparation of test specimens, the non-adherent substrate can be, for example, a polyethylene (PE) film or a micro-porous polytetrafluorethylene (PTFE) film, preferably on the advice of the sealant manufacturer.

iTeh STANDARD PREVIEW
(standards.iteh.ai)

5.4 Masking tape

The masking tape shall be suitable for covering the tested surface of the substrates (see [Figure 1](#)) to prevent sealant contamination during specimen preparation.

<https://standards.iteh.ai/catalog/standards/sist/4984a4b3-176d-4975-aa50-93deb802aeba/iso-16938-1-2019>

5.5 Ventilated convection-type oven

The ventilated convection-type oven shall be capable of being maintained at (70 ± 2) °C.

5.6 Refrigerated enclosure

The refrigerated enclosure shall be capable of being maintained at (-20 ± 2) °C.

5.7 Clamps or other device

The clamps are for maintaining the specimen under compression (see [Table 1](#)).

5.8 Actinic radiation accelerated aging apparatus

5.8.1 General

A fluorescent ultraviolet radiation/condensation test apparatus or xenon light test apparatus shall be employed as the actinic radiation accelerated aging apparatus.

NOTE Test results can differ between the exposure to fluorescent ultraviolet radiation/condensation and xenon light because of differences in the spectral power distribution of the radiation source and differences in the exposure conditions a) to d) in [8.2.4](#).

5.8.2 Fluorescent ultraviolet radiation/condensation test apparatus

The apparatus shall provide the ultraviolet radiation with fluorescent UVA-340 lamps having their peak emission at 343 nm, capable of exposing the test specimens to radiation under controlled conditions of

temperature and moisture or water, complying with the requirements of ISO 4892-3. Standard practices for operating such accelerated weathering chambers are described in ISO 4892-1. The target value for irradiance at 340 nm shall be $(0,77 \pm 0,02) \text{ W/m}^2$ at 60 °C.

5.8.3 Xenon light test apparatus

The apparatus shall provide the xenon light source with daylight filter, capable of exposing the test specimens to radiation under controlled conditions of temperature and water, complying with the requirements of ISO 4892-2:2013, Table 3, Method A (cycle 1) or Table B.1 (cycle B1). Irradiance at the surface of the test specimens between the wavelength of 290 nm and 800 nm shall be $(550 \pm 75) \text{ W/m}^2$. Irradiance below 300 nm shall not exceed 1 W/m^2 .

5.9 Black standard thermometer

The black standard thermometer shall comply with the requirements of ISO 4892-1. All temperatures reported in this document for the UV exposure apparatus are measured with the black standard thermometer. Black panel thermometers may also be used. Under given operating conditions, they tend to indicate lower temperatures than the black standard thermometer. The temperature difference between the measurements will depend on the test temperature, but can be up to 10 °C.

5.10 Measuring device

The measuring device shall be scaled in half millimetres.

6 Preparation of test specimens

Four test specimens for each sealant and each aging method shall be prepared.

For each test specimen, two substrate materials (5.1) and two spacers (5.2) shall be assembled (see Figure 1) and set up on the non-adherent substrate (5.3).

The instructions of the sealant manufacturer concerning, for instance, whether a primer is to be used, and the mixing procedure for multi-component sealants, shall be followed.

The following procedure shall be used for specimen preparation:

- a) the sealant and the substrate materials (5.1) shall be brought to $(23 \pm 2) \text{ °C}$;
- b) the tested surface of both substrate materials shall be placed in the same plane as the tooled surface of the sealant (see Figure 1);
- c) the masking tape (5.4) shall be applied on the tested surfaces of the substrate materials to prevent sealant contamination during specimen preparation;
- d) the hollow volume formed by the substrate materials and spacers (5.2) shall be filled with the sealant (avoiding the formation of air bubbles);
- e) the sealant shall be pressed to the inner surfaces of the substrate materials;
- f) the sealant surface shall be trimmed so that it is flush with the masking tapes on the faces of the substrate materials and spacers;
- g) immediately following the application and tooling of the sealant, the masking tape shall be removed;
- h) the test specimens shall be set on edge on one of the substrate materials and the non-adherent substrate removed as soon as possible; the specimens shall remain in this position with the spacers in place for another 48 h to allow curing or optimum drying of the sealant.

Dimensions in millimetres

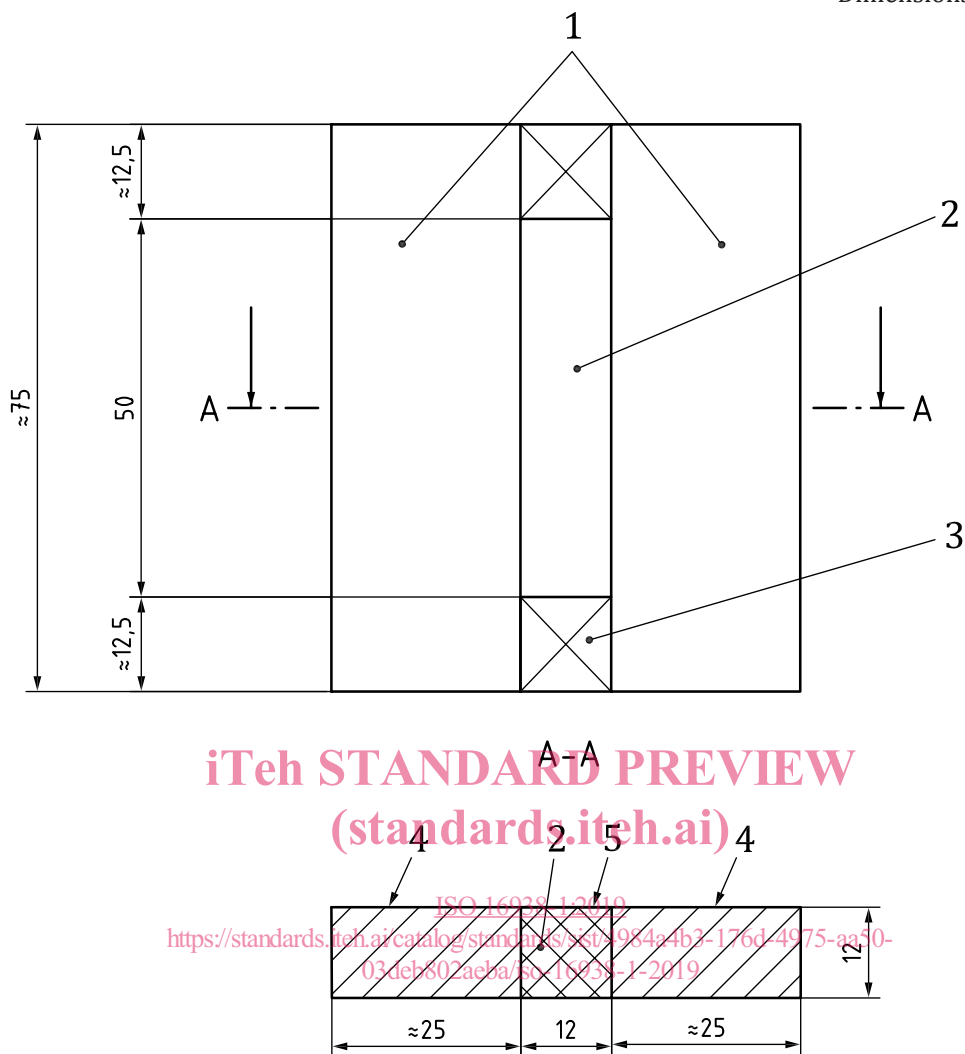

Key

- 1 substrate
- 2 sealant
- 3 spacer
- 4 tested surface
- 5 tooled surface

Figure 1 — Test specimen assembly

7 Conditioning

The test specimens shall be conditioned for 28 d at $(23 \pm 2) ^\circ\text{C}$ and $(50 \pm 10) \%$ relative humidity.

8 Test procedure

8.1 Compression

All test specimens shall be compressed by a percentage equal to the movement capability for the sealant under test. This compression shall be 7,5 %, 12,5 %, 20 % or 25 % or any other compression

as agreed by the concerned parties. The sealant shall be held at this compression (see [Table 1](#)) using suitable clamps ([5.7](#)).

Table 1 — Correspondence of movement capability, compression and joint width after compression

Movement capability %	Compression %	Joint width after compression mm
7,5	7,5	11,1
12,5	12,5	10,5
20	20	9,6
25	25	9,0

8.2 Aging procedures

8.2.1 General

One or more of the following aging procedures ([8.2.2](#), [8.2.3](#), [8.2.4](#)) shall be carried out as agreed between the concerned parties.

8.2.2 Heat aging

Four of the compressed specimens shall be placed in an oven ([5.5](#)) at (70 ± 2) °C. Remove two specimens after 14 d and the other two specimens after 28 d.

8.2.3 Cold aging

Four of the compressed specimens shall be placed in a refrigerated enclosure ([5.6](#)) at (-20 ± 2) °C. Remove two specimens after 14 d and the other two specimens after 28 d.

8.2.4 Actinic radiation aging

As agreed between the concerned parties, the test specimens shall be exposed to actinic radiation according to one of the following aging procedures:

- UV fluorescent radiation condensation apparatus ([5.8.2](#)) with wet exposure condition [see a)];
- xenon lamp test apparatus ([5.8.3](#)) with wet exposure condition [see b)];
- UV fluorescent radiation condensation apparatus ([5.8.2](#)) with dry exposure condition [see c)];
- xenon lamp test apparatus ([5.8.3](#)) with dry exposure condition [see d)].

Four of the compressed specimens shall be placed in the actinic radiation exposure apparatus, with the tested surface perpendicularly facing the radiation source. Two specimens shall be removed after 14 d and the other two specimens after 28 d.

Wet exposure:

- a) In the UV fluorescent radiation/condensation test apparatus the sealant surface shall be held 50 mm from the radiation source. The cycle of the UV fluorescent radiation/condensation test apparatus shall be set to 8 h UV radiation at (60 ± 2) °C, and 4 h condensation at (50 ± 2) °C.
- b) In the xenon-lamp test apparatus, the specimens shall be exposed to cycles of dry periods with radiation followed by wet periods (water spray or immersion) as defined in ISO 11431:2002, 8.2.2 (automatic cycling) or 8.2.3 (manual cycling).