



Designation: C1506 – 09

# Standard Test Method for Water Retention of Hydraulic Cement-Based Mortars and Plasters<sup>1</sup>

This standard is issued under the fixed designation C1506; the number immediately following the designation indicates the year of original adoption or, in the case of revision, the year of last revision. A number in parentheses indicates the year of last reapproval. A superscript epsilon ( $\epsilon$ ) indicates an editorial change since the last revision or reapproval.

## 1. Scope\*

1.1 This test method provides for the determination of water retention of hydraulic cement-based mortars and plasters.

1.2 The values stated in SI units are to be regarded as standard. No other units of measurement are included in this standard.

1.3 *This standard does not purport to address all of the safety concerns, if any, associated with its use. It is the responsibility of the user of this standard to establish appropriate safety and health practices and determine the applicability of regulatory limitations prior to use. (Warning—Fresh hydraulic cementitious mixtures are caustic and may cause chemical burns to skin and tissue upon prolonged exposure.)<sup>2</sup>*

## 2. Referenced Documents

2.1 *ASTM Standards*:<sup>3</sup>

[C109/C109M Test Method for Compressive Strength of Hydraulic Cement Mortars \(Using 2-in. or \[50-mm\] Cube Specimens\)](#)

[C185 Test Method for Air Content of Hydraulic Cement Mortar](#)

[C230/C230M Specification for Flow Table for Use in Tests of Hydraulic Cement](#)

[C305 Practice for Mechanical Mixing of Hydraulic Cement Pastes and Mortars of Plastic Consistency](#)

[C511 Specification for Mixing Rooms, Moist Cabinets, Moist Rooms, and Water Storage Tanks Used in the Testing of Hydraulic Cements and Concretes](#)

[C670 Practice for Preparing Precision and Bias Statements for Test Methods for Construction Materials](#)

[C1437 Test Method for Flow of Hydraulic Cement Mortar](#)

<sup>1</sup> This test method is under the jurisdiction of ASTM Committee C01 on Cement and is the direct responsibility of Subcommittee C01.22 on Workability.

Current edition approved Dec. 1, 2009. Published January 2010. Originally approved in 2001. Last previous edition approved in 2008 as C1506–08. DOI: 10.1520/C1506-09.

<sup>2</sup> Section on Safety, Manual of Cement Testing, *Annual Book of ASTM Standards*, Vol 04.01.

<sup>3</sup> For referenced ASTM standards, visit the ASTM website, www.astm.org, or contact ASTM Customer Service at service@astm.org. For *Annual Book of ASTM Standards* volume information, refer to the standard's Document Summary page on the ASTM website.

## 3. Summary of Test Method

3.1 The flow of the mortar or plaster is determined. The mortar or plaster is then subjected to a controlled vacuum suction for 60 s, after which the flow is again determined. The water retention is the final flow divided by the initial flow expressed as a percentage.

## 4. Significance and Use

4.1 This test method provides a means for determining the ability of mortars and plasters to retain water under suction. Test results may be used to determine compliance with specifications.

4.2 The results obtained using this test method can be used to compare the relative ability of mortars and plasters to retain water under suction.

4.3 The results obtained using this test method for masonry mortars do not necessarily indicate the degree of water retention when used with masonry units, since the amount of water absorbed by the unit depends on the rate of absorption of the masonry unit.

4.4 The results obtained using this test method for plasters (stucco) do not necessarily indicate the degree of water retention when the plaster is applied as a second coat on the surface of a previously applied plaster base coat, since the amount of water absorbed from the second coat of plaster depends on the rate of absorption of the base coat. This is also true when a plaster is applied as a coating on masonry units.

## 5. Apparatus

5.1 *Tamper*, conforming to Test Method [C109/C109M](#).

5.2 *Straightedge*, conforming to Test Method [C185](#).

5.3 *Flow Table*, conforming to Specification [C230/C230M](#).

5.4 *Mixing Apparatus*, conforming to the requirements prescribed in Practice [C305](#).

5.5 *Filtration Assembly*, an apparatus essentially as shown in [Fig. 1](#) shall be used. This apparatus consists of a perforated dish resting on a funnel, which is connected by a three-way stopcock to a vacuum flask, to which a controlled vacuum is applied. The perforated dish shall be made of metal not attacked by masonry mortar or plaster ([Note 1](#)). The metal base

\*A Summary of Changes section appears at the end of this standard

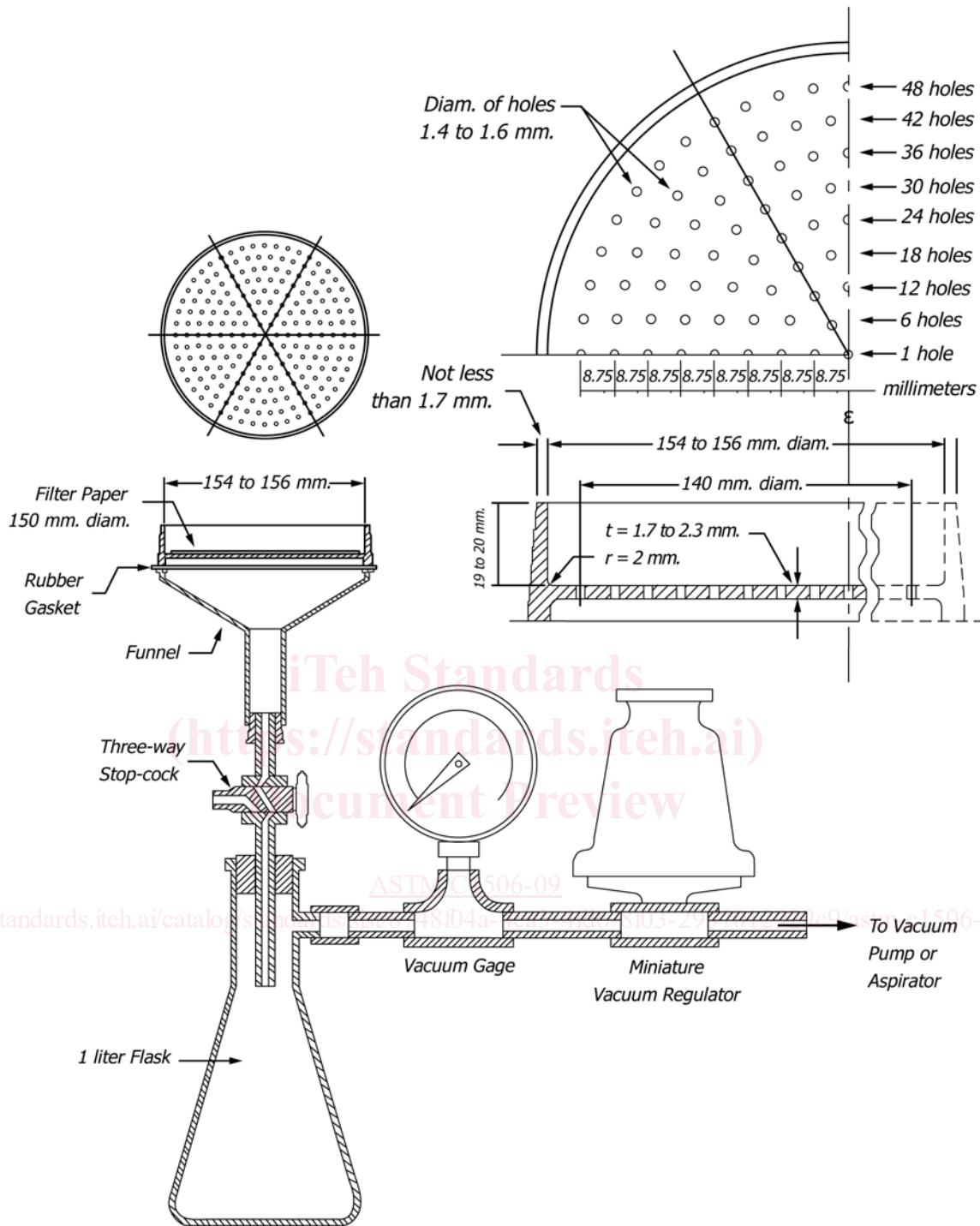

NOTE 1—The gasket is to be synthetic rubber. The stopcock and the bore of the tubing shall be at least 4-mm. A check valve or water trap, or both, is suggested for the connection to the vacuum source.

FIG. 1 Apparatus Assembly for the Water-Retention Test

of the dish shall have a thickness of  $2.0 \pm 0.3$  mm and shall conform to the requirements given in Fig. 1. The stopcock bore shall have a  $4.0 \pm 0.5$ -mm diameter, and the connecting glass tubing shall have a minimum inside diameter of 4 mm. The length of the tubing projecting into the 1-L flask from the stopcock shall extend at least 25 mm below the center line of the vacuum connection. The contact surfaces of the funnel and

perforated dish shall be plane and may need to be lapped to ensure intimate contact. An airtight seal shall be maintained between the funnel and the dish during the test. This shall be accomplished by either of the following procedures. (1) A synthetic (grease-resistant) rubber gasket may be permanently sealed to the top of the funnel using petrolatum or light grease to ensure a seal between the gasket and dish. (2) The top of the