**Passenger car and light truck vehicle
wheels — Clip and adhesive balance
weight and rim flange nomenclature,
test procedures and performance
requirements**

*Roues pour véhicules particuliers et camionnettes — Nomenclature
des masselottes d'équilibrage clippées et adhésives ainsi que des
rebords de jantes, méthodes d'essai et exigences de performance*

iTeh STANDARD PREVIEW
(standards.iteh.ai)

[ISO 13988:2021](https://standards.iteh.ai/catalog/standards/sist/cfd64a8-429b-4223-ad1e-f43f675c774/iso-13988-2021)

<https://standards.iteh.ai/catalog/standards/sist/cfd64a8-429b-4223-ad1e-f43f675c774/iso-13988-2021>



iTeh STANDARD PREVIEW (standards.iteh.ai)

ISO 13988:2021

<https://standards.iteh.ai/catalog/standards/sist/cfd64a8-429b-4223-ad1e-f43f675c774/iso-13988-2021>



COPYRIGHT PROTECTED DOCUMENT

© ISO 2021

All rights reserved. Unless otherwise specified, or required in the context of its implementation, no part of this publication may be reproduced or utilized otherwise in any form or by any means, electronic or mechanical, including photocopying, or posting on the internet or an intranet, without prior written permission. Permission can be requested from either ISO at the address below or ISO's member body in the country of the requester.

ISO copyright office
CP 401 • Ch. de Blandonnet 8
CH-1214 Vernier, Geneva
Phone: +41 22 749 01 11
Email: copyright@iso.org
Website: www.iso.org

Published in Switzerland

Contents

	Page
Foreword.....	iv
Introduction.....	v
1 Scope.....	1
2 Normative references.....	1
3 Terms and definitions.....	1
4 Rim flange types.....	6
5 Test procedure for clip on balance weight.....	6
5.1 Preparation of clip on balance weight for test.....	6
5.1.1 Selection of balance weights.....	6
5.1.2 Measurement of key dimensions of balance weights.....	6
5.1.3 Marking of balance weights.....	6
5.2 Preparation of the wheel for clip on balance weight testing.....	7
5.2.1 Cleaning.....	7
5.2.2 Marking.....	7
5.2.3 Measurement of rim flange dimensions.....	7
5.3 Installation of clip on balance weight.....	7
5.4 Tangential test for clip on balance weight.....	8
5.4.1 General.....	8
5.4.2 Test equipment.....	8
5.4.3 Test sequence.....	9
5.4.4 Performance requirements tangential force.....	9
5.5 Axial removal test for clip on balance weight.....	9
5.5.1 Test equipment.....	9
5.5.2 Test sequence.....	9
5.5.3 Performance requirement axial force.....	11
6 Test procedure for adhesive balance weights for all size weights and wheels.....	11
6.1 Test equipment.....	11
6.2 Wheel preparation.....	12
6.3 Balance weight selection and installation.....	12
7 Shear adhesion test.....	13
7.1 Test procedure.....	13
7.2 Performance.....	13
8 Pull-off adhesion test.....	13
8.1 Test procedure.....	13
8.2 Performance.....	14

Foreword

ISO (the International Organization for Standardization) is a worldwide federation of national standards bodies (ISO member bodies). The work of preparing International Standards is normally carried out through ISO technical committees. Each member body interested in a subject for which a technical committee has been established has the right to be represented on that committee. International organizations, governmental and non-governmental, in liaison with ISO, also take part in the work. ISO collaborates closely with the International Electrotechnical Commission (IEC) on all matters of electrotechnical standardization.

The procedures used to develop this document and those intended for its further maintenance are described in the ISO/IEC Directives, Part 1. In particular, the different approval criteria needed for the different types of ISO documents should be noted. This document was drafted in accordance with the editorial rules of the ISO/IEC Directives, Part 2 (see www.iso.org/directives).

Attention is drawn to the possibility that some of the elements of this document may be the subject of patent rights. ISO shall not be held responsible for identifying any or all such patent rights. Details of any patent rights identified during the development of the document will be in the Introduction and/or on the ISO list of patent declarations received (see www.iso.org/patents).

Any trade name used in this document is information given for the convenience of users and does not constitute an endorsement.

For an explanation of the voluntary nature of standards, the meaning of ISO specific terms and expressions related to conformity assessment, as well as information about ISO's adherence to the World Trade Organization (WTO) principles in the Technical Barriers to Trade (TBT), see www.iso.org/iso/foreword.html.

This document was prepared by Technical Committee ISO/TC 22, *Road vehicles*, Subcommittee SC 33, *Vehicle dynamics and chassis components*.

This second edition cancels and replaces the first edition (ISO 13988:2008), which has been technically revised. The main changes compared with the previous edition are as follows:

- adhesive balance weights have been added, which covers clip on weights only;
- nomenclature for the balance weight and test procedures and performance requirements for the adhesive weights have been included.

Any feedback or questions on this document should be directed to the user's national standards body. A complete listing of these bodies can be found at www.iso.org/members.html.

Introduction

This document addresses clip and adhesive balance weights used on passenger car wheels. It provides general features and configurations of the clip balance weights, general features of the adhesive balance weights, and general features and configurations for rim dimensions relevant to clip on weights and defines terms used to describe these features.

This document provides test procedures to evaluate weight retention on the wheel.

iTeh STANDARD PREVIEW
(standards.iteh.ai)

ISO 13988:2021

<https://standards.iteh.ai/catalog/standards/sist/cfd64a8-429b-4223-ad1e-f43f675c774/iso-13988-2021>

iTeh STANDARD PREVIEW
(standards.iteh.ai)

ISO 13988:2021

<https://standards.iteh.ai/catalog/standards/sist/cfd64a8-429b-4223-ad1e-f43f675c774/iso-13988-2021>

Passenger car and light truck vehicle wheels — Clip and adhesive balance weight and rim flange nomenclature, test procedures and performance requirements

1 Scope

This document specifies procedures and minimum performance requirements for testing without tyres the retention of balance weights for use on wheels for passenger vehicles. It also specifies general features for configurations of clip balance weights, rim flanges for light alloy and steel wheels intended for use on passenger cars and adhesive balance weights. Alternative materials and geometries can be considered in the future.

2 Normative references

The following documents are referred to in the text in such a way that some or all of their content constitutes requirements of this document. For dated references, only the edition cited applies. For undated references, the latest edition of the referenced document (including any amendments) applies.

ISO 3911, *Wheels and rims for pneumatic tyres — Vocabulary, designation and marking*

ISO 4000-1, *Passenger car tyres and rims — Part 1: Tyres (metric series)*

ISO 4000-2, *Passenger car tyres and rims — Part 2: Rims*

ISO 4223-1, *Definitions of some terms used in the tyre industry — Part 1: Pneumatic tyres*

3 Terms and definitions

For the purposes of this document, the terms and definitions given in ISO 3911, ISO 4000-1, ISO 4000-2, ISO 4223-1 and the following apply.

ISO and IEC maintain terminological databases for use in standardization at the following addresses:

- ISO Online browsing platform: available at <https://www.iso.org/obp>
- IEC Electropedia: available at <https://www.electropedia.org/>

3.1

clip balance weight assembly

assembly of the *weight* (3.1.1) and the *clip* (3.1.3), which is intended for mounting on the *rim flange* (3.3) to balance the tyre/wheel assembly about its axis of rotation and thus minimize vibrations due to the rotation of the tyre/wheel assembly

Note 1 to entry: [Figure 1](#) gives the terminology and nomenclature of balance weight assembly.

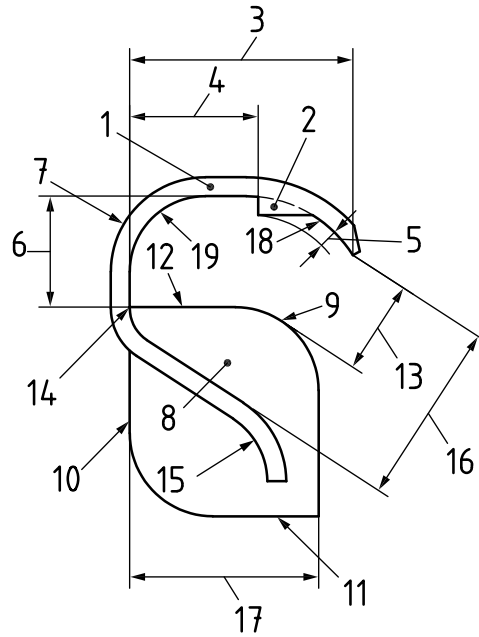

Key

1 clip	7 outer surface of clip	13 weight gap
2 spur	8 balance weight	14 clip insertion point
3 clip depth	9 contact radius	15 back leg of clip
4 spur location	10 front surface	16 clip gap
5 spur depth	11 bottom surface	17 weight depth
6 clip height	12 top surface	18 compound radius
		19 compound radius

Figure 1 — Clip balance weight assembly terminology

3.1.1

weight

material of a specified mass with contours to conform to the surface of the *rim flange* (3.3)

Note 1 to entry: The material is recommended to be free of lead.

3.1.2

clip

specially formed metal affixed to the *weight* (3.1.1) to mount the balance weight on the *rim flange* (3.3)

3.1.3

spur

optional part of a *clip* (3.1.3) that protrudes from its surface interfacing with the *rim flange* (3.3)

3.1.4

balance weight coating

non-corrosive material coating to avoid corrosion

EXAMPLE Polyester, nylon.

3.1.5

balance weight key dimensions

dimensions that are essential for fitting the balance *weight* (3.1.1) on the *rim flange* (3.3)

3.1.6**balance weight size**

size determined by the magnitude of the balance *weight* (3.1.1) mass

Note 1 to entry: Balance weight size is expressed in grams.

3.1.7**balance weight retention force**

static force required to remove the balance *weight* (3.1.1) from the *rim flange* (3.3)

Note 1 to entry: Balance weight retention force is expressed in newtons.

3.1.8**balance weight retention**

ability of the balance *weight* (3.1.1) to maintain its secure position on the *rim flange* (3.3) in various service conditions

3.1.9**interference**

measure of balance *weight* (3.1.1) press fit computed as the difference between the flange thickness and the weight gap

3.2**adhesive balance weight assembly**

assembly of the *weight portion* (3.2.1) and the adhesive portion, which is intended for mounting on the rim to balance the tyre/wheel assembly about its axis of rotation and thus minimize vibrations due to the rotation of the tyre/wheel assembly

Note 1 to entry: [Figure 2](#) gives the terminology and nomenclature of the adhesive balance *weight* (3.1.1) assembly.

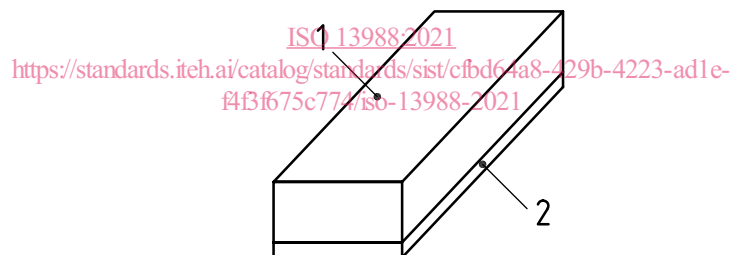
**Key**

- 1 weight
- 2 adhesive

Figure 2 — Adhesive balance weight assembly terminology

3.2.1**weight portion**

portion of the *weight* (3.1.1) that provide mass for balancing the wheel

Note 1 to entry: The material is recommended to be free of lead.

3.2.2**tape portion**

double-sided adhesive tape with three layers: a) adhesive for the *weight portion* (3.2.1), b) a backing material, and c) adhesive for attachment to the wheel surface

3.3 rim flange

part of the rim where the *clip* (3.1.3) balance *weight* (3.1.1) is mounted

Note 1 to entry: [Figure 3](#) gives the terminology and nomenclature of rim flange features for light alloy wheels.

Note 2 to entry: [Figure 4](#) gives the terminology and nomenclature of rim flange features for wheels with rolled formed rim.

Note 3 to entry: [Figure 5](#) gives the terminology and nomenclature of rim flange features for fullface wheels.

Note 4 to entry: [Figure 6](#) gives the terminology and nomenclature of rim flange features for clad wheels.

3.3.1 rim flange key dimensions

dimensions that are essential for fitting *clip* (3.1.3) balance *weight* (3.1.1) on the *rim flange* (3.3)

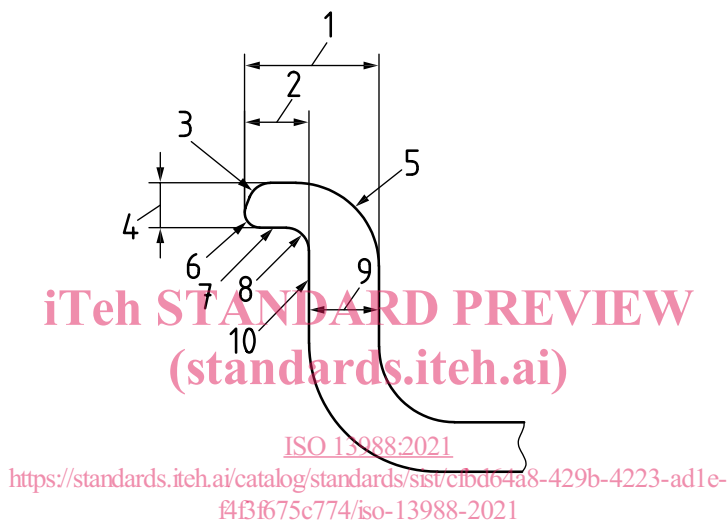

Key

- | | | | |
|---|----------------------------------|----|--|
| 1 | flange width | 6 | break corner radius at balance weight side |
| 2 | flange offset | 7 | balance weight side |
| 3 | break corner radius at tyre side | 8 | rim flange radius at balance weight side |
| 4 | flange lip thickness | 9 | flange wall thickness |
| 5 | rim flange radius at tyre side | 10 | contact surface |

Figure 3 — Light alloy rim flange terminology

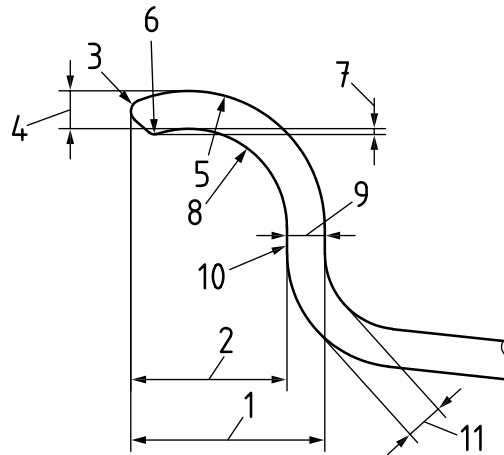

Key

- | | | | |
|---|----------------------------------|----|---|
| 1 | flange width | 6 | flange compound radius at balance weight side |
| 2 | flange offset | 7 | flange curl |
| 3 | break corner radius at tyre side | 8 | flange radius at balance weight side |
| 4 | flange lip thickness | 9 | flange wall thickness |
| 5 | rim flange radius at tyre side | 10 | contact surface |
| | | 11 | flange bead seat thickness |

Figure 4 — Rolled formed rim flange terminology
(standards.iteh.ai)

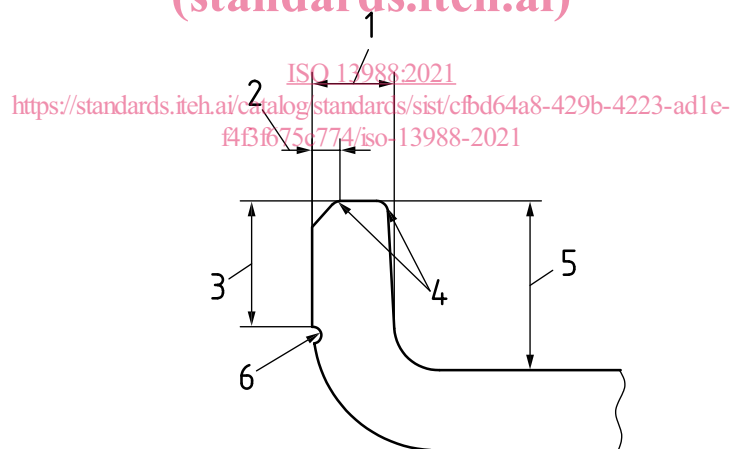

Key

- | | | | |
|---|----------------------|---|-----------------|
| 1 | flange lip thickness | 4 | break corner |
| 2 | weight lead in | 5 | flange offset |
| 3 | groove location | 6 | optional groove |

Figure 5 — Fullface rim flange terminology