

FINAL  
DRAFT

INTERNATIONAL  
STANDARD

ISO/FDIS  
10535

ISO/TC 173

Secretariat: SIS

Voting begins on:  
2021-06-04

Voting terminates on:  
2021-07-30

---

---

## Assistive products — Hoists for the transfer of disabled persons — Requirements and test methods

*Produits d'assistance — Lève-personnes pour transférer des  
personnes handicapées — Exigences et méthodes d'essai*

**iTeh STANDARD PREVIEW**  
**(standards.iteh.ai)**

[ISO/FDIS 10535](https://standards.iteh.ai/catalog/standards/sist/33316009-c1ad-4c1b-84c9-e5e8fbc107b/iso-fdis-10535)

[https://standards.iteh.ai/catalog/standards/sist/33316009-c1ad-4c1b-84c9-  
e5e8fbc107b/iso-fdis-10535](https://standards.iteh.ai/catalog/standards/sist/33316009-c1ad-4c1b-84c9-e5e8fbc107b/iso-fdis-10535)

RECIPIENTS OF THIS DRAFT ARE INVITED TO SUBMIT, WITH THEIR COMMENTS, NOTIFICATION OF ANY RELEVANT PATENT RIGHTS OF WHICH THEY ARE AWARE AND TO PROVIDE SUPPORTING DOCUMENTATION.

IN ADDITION TO THEIR EVALUATION AS BEING ACCEPTABLE FOR INDUSTRIAL, TECHNOLOGICAL, COMMERCIAL AND USER PURPOSES, DRAFT INTERNATIONAL STANDARDS MAY ON OCCASION HAVE TO BE CONSIDERED IN THE LIGHT OF THEIR POTENTIAL TO BECOME STANDARDS TO WHICH REFERENCE MAY BE MADE IN NATIONAL REGULATIONS.

**ISO/CEN PARALLEL PROCESSING**



Reference number  
ISO/FDIS 10535:2021(E)

© ISO 2021

**iTeh STANDARD PREVIEW**  
**(standards.iteh.ai)**

[ISO/FDIS 10535](https://standards.iteh.ai/catalog/standards/sist/33316009-c1ad-4c1b-84c9-e5e8fbc107b/iso-fdis-10535)

<https://standards.iteh.ai/catalog/standards/sist/33316009-c1ad-4c1b-84c9-e5e8fbc107b/iso-fdis-10535>



**COPYRIGHT PROTECTED DOCUMENT**

© ISO 2021

All rights reserved. Unless otherwise specified, or required in the context of its implementation, no part of this publication may be reproduced or utilized otherwise in any form or by any means, electronic or mechanical, including photocopying, or posting on the internet or an intranet, without prior written permission. Permission can be requested from either ISO at the address below or ISO's member body in the country of the requester.

ISO copyright office  
CP 401 • Ch. de Blandonnet 8  
CH-1214 Vernier, Geneva  
Phone: +41 22 749 01 11  
Email: [copyright@iso.org](mailto:copyright@iso.org)  
Website: [www.iso.org](http://www.iso.org)

Published in Switzerland

# Contents

	Page
<b>Foreword</b> .....	<b>vii</b>
<b>Introduction</b> .....	<b>viii</b>
<b>1 Scope</b> .....	<b>1</b>
<b>2 Normative references</b> .....	<b>1</b>
<b>3 Terms and definitions</b> .....	<b>2</b>
<b>4 General requirements and test methods</b> .....	<b>8</b>
4.1 General requirements.....	8
4.1.1 Risk management.....	8
4.1.2 Ergonomic factors.....	8
4.1.3 Noise and vibration.....	8
4.1.4 Safety of moving and folding parts.....	9
4.1.5 Prevention of traps for parts of the human body.....	10
4.1.6 V-shaped openings.....	11
4.2 General test methods.....	11
4.2.1 Test conditions.....	11
4.2.2 Apparatus.....	11
4.2.3 Permissible errors of test equipment.....	12
4.2.4 Test report.....	12
4.2.5 Safety and performance requirements.....	16
4.2.6 Test methods for general safety requirements.....	19
4.3 Requirements for body-support units.....	22
4.4 Central suspension point.....	22
4.4.1 Requirements for central suspension point.....	22
4.4.2 Test method for the central suspension point.....	22
4.5 Spreader bar.....	22
4.5.1 Requirements for spreader bar.....	22
4.5.2 Test methods for the spreader bar.....	23
4.6 Performance.....	23
4.6.1 Requirements for performance.....	23
4.6.2 Test methods for performance.....	23
4.7 Rate of movements of the hoist.....	24
4.7.1 Requirements for rate of lifting and lowering.....	24
4.7.2 Test methods for rate of lifting and lowering.....	24
4.7.3 Requirements for rate of powered horizontal movement.....	24
4.7.4 Test methods for rate of powered horizontal movement.....	24
4.8 Operating forces/torques.....	24
4.8.1 Requirements for operating forces/torques.....	24
4.8.2 Test methods for operating forces/torques.....	25
4.9 Durability.....	25
4.9.1 Requirements for durability.....	25
4.9.2 Test methods for durability.....	25
4.10 Hydraulic components.....	27
4.10.1 Requirements for hydraulic components.....	27
4.10.2 Test methods for hydraulic components.....	28
4.11 Pneumatic components.....	28
4.11.1 Requirements for pneumatic components.....	28
4.11.2 Test methods for pneumatic components.....	28
4.12 Machine washable hoists.....	29
4.12.1 Requirements for machine washable hoists.....	29
4.12.2 Test methods for machine washable hoists.....	29
4.13 Requirement for information supplied by the manufacturer.....	30
4.13.1 General.....	30
4.13.2 Instructions for use.....	30

4.13.3	Labelling.....	32
<b>5</b>	<b>Mobile hoists — Specific requirements and test methods.....</b>	<b>37</b>
5.1	General requirements.....	37
5.2	Static strength.....	37
5.2.1	Requirements for static strength.....	37
5.2.2	Test methods for static strength.....	37
5.3	Static stability.....	38
5.3.1	Requirements for static stability.....	38
5.3.2	Test methods for static stability.....	38
5.4	Immobilizing device (brakes).....	38
5.4.1	Requirements for immobilizing device (brakes).....	38
5.4.2	Test methods for immobilizing device (brakes).....	38
5.5	Moving forces.....	39
5.5.1	Requirements for moving forces.....	39
5.5.2	Test methods for moving forces.....	39
5.6	Requirement for information supplied by the manufacturer.....	40
5.6.1	Pre-sale information.....	40
<b>6</b>	<b>Mobile hoists for transferring a person in standing position— Specific requirements and test methods.....</b>	<b>41</b>
6.1	General requirements.....	41
6.2	Static strength.....	41
6.2.1	Requirements for static strength.....	41
6.2.2	Test method for static strength.....	41
6.3	Static stability.....	41
6.3.1	Requirements for static stability.....	41
6.3.2	Test methods for static stability.....	42
6.4	Immobilizing device (brakes).....	43
6.4.1	Requirements for immobilizing device (brakes).....	43
6.4.2	Test methods for immobilizing device (brakes).....	43
6.5	Moving forces.....	43
6.5.1	Requirements for moving forces.....	43
6.5.2	Test methods for moving forces.....	43
6.6	Durability.....	43
6.6.1	Requirements for durability.....	43
6.6.2	Test methods for durability.....	43
6.7	Requirement for information supplied by the manufacturer.....	44
6.7.1	Pre-sale information.....	44
<b>7</b>	<b>Stationary hoists — Specific requirements and test methods.....</b>	<b>44</b>
7.1	General requirements.....	44
7.2	Specific safety requirements.....	45
7.2.1	Requirements for specific safety requirements.....	45
7.2.2	Test methods for specific safety requirements.....	45
7.3	Static strength (free-standing stationary hoists only).....	45
7.3.1	Requirements for static strength (free-standing stationary hoists only).....	45
7.3.2	Test methods for static strength (free-standing stationary hoists only).....	45
7.4	Static stability (free-standing stationary hoists only).....	46
7.4.1	Requirements for static stability (free-standing stationary hoists only).....	46
7.4.2	Test methods for static stability (free-standing stationary hoists only).....	46
7.5	Static strength for all other stationary hoists.....	47
7.5.1	Requirements for static strength for all other stationary hoists.....	47
7.5.2	Test methods for static strength for all other stationary hoists.....	47
7.6	Requirement for information supplied by the manufacturer.....	47
7.6.1	User information.....	47
<b>8</b>	<b>Non-rigid body-support units — Specific requirements and test methods.....</b>	<b>47</b>
8.1	General requirements.....	47
8.2	Requirements for material and seams of the non-rigid body-support unit.....	47

8.3	Test methods for non-rigid body-support unit .....	48
8.3.1	Test methods for non-rigid body-support unit designed to be laundered .....	48
8.3.2	Test method for durability for non-rigid body-support unit .....	48
8.4	Requirement for information supplied by the manufacturer .....	48
8.4.1	Pre-sale information .....	48
8.4.2	User information .....	48
8.4.3	Labelling .....	49
<b>9</b>	<b>Rigid body-support units — Specific requirements and test methods .....</b>	<b>49</b>
9.1	General requirements .....	49
9.2	Requirements for backrest .....	50
9.3	Requirements and test methods for durability .....	50
9.4	Requirement for information supplied by the manufacturer .....	50
9.4.1	User information .....	50
9.4.2	Labelling .....	50
<b>10</b>	<b>Bathtub hoists — Specific requirements and test methods .....</b>	<b>51</b>
10.1	General requirements .....	51
10.1.1	General .....	51
10.1.2	Risk analysis .....	51
10.1.3	Ergonomic factors .....	51
10.1.4	Noise .....	51
10.1.5	Safety of moving and folding parts .....	51
10.1.6	Prevention of traps for parts of the human body .....	51
10.1.7	V-shaped openings .....	51
10.2	General test methods .....	52
10.2.1	Test conditions .....	52
10.2.2	Test equipment .....	52
10.2.3	Permissible errors of test equipment .....	52
10.2.4	Test report .....	52
10.3	Safety requirements .....	52
10.3.1	General safety requirements .....	52
10.3.2	Test methods for general safety requirements .....	52
10.4	Body-support units .....	53
10.5	Spreader bar .....	53
10.6	Performance .....	53
10.7	Rate of movements of the hoist .....	53
10.8	Operating forces/torques .....	53
10.9	Durability .....	53
10.9.1	Requirements for durability .....	53
10.9.2	Test methods for durability .....	53
10.10	Static strength and stability .....	54
10.10.1	Requirements for static strength and stability .....	54
10.10.2	Test methods for static strength and stability .....	54
10.11	Hydraulic components .....	54
10.12	Pneumatic components .....	54
10.13	Specific safety requirements .....	55
10.13.1	Requirements for specific safety requirements .....	55
10.13.2	Test methods for specific safety requirements .....	55
10.14	Non-rigid body-support units .....	55
10.15	Rigid body-support units — Requirements .....	55
10.16	Requirement for information supplied by the manufacturer .....	55
10.16.1	General .....	55
10.16.2	Instructions for use .....	55
10.16.3	Labelling .....	55
	<b>Annex A (informative) Rationale for specific safety requirements .....</b>	<b>56</b>
	<b>Annex B (informative) Periodic inspection and maintenance .....</b>	<b>58</b>
	<b>Annex C (informative) Compatibility of hoist/spreader bar/body-support units .....</b>	<b>61</b>

<b>Annex D (informative) Guidelines for colour coding for size of non-rigid body-support units .....</b>	<b>74</b>
<b>Bibliography .....</b>	<b>75</b>

**iTeh STANDARD PREVIEW**  
**(standards.iteh.ai)**

[ISO/FDIS 10535](https://standards.iteh.ai/catalog/standards/sist/33316009-c1ad-4c1b-84c9-e5e8fbc107b/iso-fdis-10535)

<https://standards.iteh.ai/catalog/standards/sist/33316009-c1ad-4c1b-84c9-e5e8fbc107b/iso-fdis-10535>

## Foreword

ISO (the International Organization for Standardization) is a worldwide federation of national standards bodies (ISO member bodies). The work of preparing International Standards is normally carried out through ISO technical committees. Each member body interested in a subject for which a technical committee has been established has the right to be represented on that committee. International organizations, governmental and non-governmental, in liaison with ISO, also take part in the work. ISO collaborates closely with the International Electrotechnical Commission (IEC) on all matters of electrotechnical standardization.

The procedures used to develop this document and those intended for its further maintenance are described in the ISO/IEC Directives, Part 1. In particular, the different approval criteria needed for the different types of ISO documents should be noted. This document was drafted in accordance with the editorial rules of the ISO/IEC Directives, Part 2 (see [www.iso.org/directives](http://www.iso.org/directives)).

Attention is drawn to the possibility that some of the elements of this document may be the subject of patent rights. ISO shall not be held responsible for identifying any or all such patent rights. Details of any patent rights identified during the development of the document will be in the Introduction and/or on the ISO list of patent declarations received (see [www.iso.org/patents](http://www.iso.org/patents)).

Any trade name used in this document is information given for the convenience of users and does not constitute an endorsement.

For an explanation of the voluntary nature of standards, the meaning of ISO specific terms and expressions related to conformity assessment, as well as information about ISO's adherence to the World Trade Organization (WTO) principles in the Technical Barriers to Trade (TBT), see [www.iso.org/iso/foreword.html](http://www.iso.org/iso/foreword.html).

This document was prepared by Technical Committee ISO/TC 173, *Assistive products*, in collaboration with the European Committee for Standardization (CEN) Technical Committee CEN/TC 293, *Assistive products and accessibility*, in accordance with the Agreement on technical cooperation between ISO and CEN (Vienna Agreement).

This third edition cancels and replaces the second edition (ISO 10535:2006), which has been technically revised.

The main changes compared to the previous edition are as follows:

- aspects on hoists with robotic features has been included;
- guidelines regarding compatibility of hoists/body-support units have been included;
- the informative annex on Inspection has been further developed;
- lowering of minimum capacity of a mobile hoist from 120 kg to 100 kg;
- requirement of emergency lowering device for mobile hoist and standing/raising hoists has been included.

Any feedback or questions on this document should be directed to the user's national standards body. A complete listing of these bodies can be found at [www.iso.org/members.html](http://www.iso.org/members.html).

## Introduction

It appears from studies that the nursing and caring profession involves many physically burdening factors in the caring for and nursing of persons with disabilities. A hoist offers a safe means of supportive lifting and moving, either assisted or independently.

This document specifies requirements and test methods that are relevant to hoists for the transfer of persons with disabilities. This document addresses further needs in terms of providing safety for both the person with a disability and the attendant, while taking into account the potential new development within robotic technology on hoist solutions.

## iTeh STANDARD PREVIEW (standards.iteh.ai)

[ISO/FDIS 10535](https://standards.iteh.ai/catalog/standards/sist/33316009-c1ad-4c1b-84c9-e5e8fbc107b/iso-fdis-10535)

<https://standards.iteh.ai/catalog/standards/sist/33316009-c1ad-4c1b-84c9-e5e8fbc107b/iso-fdis-10535>



# Assistive products — Hoists for the transfer of disabled persons — Requirements and test methods

## 1 Scope

This document specifies requirements and test methods for hoists and body-support units intended for the transfer of persons with disabilities. The document applies to the following products classified in ISO 9999:—<sup>1)</sup>.

- 12 36 03 Mobile hoists for transferring a person in sitting position with sling seats;
- 12 36 04 Mobile hoists for transferring a person in standing position;
- 12 36 06 Mobile hoists for transferring a person in sitting position with solid seats;
- 12 36 09 Mobile hoists for transferring a person in lying position;
- 12 36 12 Stationary hoists fixed to walls, floor or ceiling;
- 12 36 15 Stationary hoists fixed to, or mounted in or on, another product;
- 12 36 18 Stationary free-standing hoists;
- 12 36 21 Body-support units for hoists.

This document covers different types of mobile and stationary hoists. Some of the requirements and test methods are general and others are only valid for specific product types.

[Annexes A, B](#) and [C](#) provide general recommendations.

This document does not apply to devices that transport persons between two levels (floors) of a building.

It does not include methods for the determination of ageing or corrosion of such hoists and units.

It does not include methods to qualify individual units prior to use.

The requirements of this document are formulated with regard to the needs of both the persons being hoisted and the attendant using the hoist.

## 2 Normative references

The following documents are referred to in the text in such a way that some or all of their content constitutes requirements of this document. For dated references, only the edition cited applies. For undated references, the latest edition of the referenced document (including any amendments) applies.

ISO 3746, *Acoustics — Determination of sound power levels and sound energy levels of noise sources using sound pressure — Survey method using an enveloping measurement surface over a reflecting plane*

ISO 3758, *Textiles — Care labelling code using symbols*

ISO 10993-1, *Biological evaluation of medical devices — Part 1: Evaluation and testing within a risk management process*

ISO 14971, *Medical devices — Application of risk management to medical devices*

1) Under preparation. Stage at the time of publication: ISO/DIS 9999:2020.

## ISO/FDIS 10535:2021(E)

ISO 15223-1:2021, *Medical devices — Symbols to be used with medical device labels, labelling and information to be supplied — Part 1: General requirements*

ISO 20417, *Medical devices — Information to be supplied by the manufacturer*

IEC 60204-1, *Safety of machinery - Electrical equipment of machines - Part 1: General requirements*

IEC 60529, *Degrees of protection provided by enclosures (IP Code)*

IEC 60601-1:2005+AMD 1:2012, *Medical electrical equipment — Part 1: General requirements for basic safety and essential performance*

IEC 60601-1-2:2014, *Medical electrical equipment — Part 1-2: General requirements for safety — Collateral standard: Electromagnetic compatibility — Requirements and tests*

IEC 61672-1, *Electroacoustics — Sound level meters — Part 1: Specifications*

EN 853, *Rubber hoses and hose assemblies — Wire braid reinforced hydraulic type — Specification*

EN 854, *Rubber hoses and hose assemblies — Textile reinforced hydraulic type — Specification*

EN 1021-1, *Furniture — Assessment of the ignitability of upholstered furniture — Part 1: Ignition source smouldering cigarette*

EN 1021-2, *Furniture — Assessment of the ignitability of upholstered furniture — Part 2: Ignition source match flame equivalent*

EN 13480-3:2017, *Metallic industrial piping — Part 3: Design and calculation*

ITeH STANDARD PREVIEW  
(standards.iteh.ai)

### 3 Terms and definitions

For the purposes of this document, the following terms and definitions apply.

ISO and IEC maintain terminological databases for use in standardization at the following addresses:

- ISO Online browsing platform: available at <https://www.iso.org/obp>
- IEC Electropedia: available at <http://www.electropedia.org/>

#### 3.1 adverse condition

condition in which failure is most likely to occur

#### 3.2 attendant

person who operates the hoist if not the *person with disability* (3.36)

#### 3.3 backrest

part of the *body-support unit* (3.6) that provides support to the back of the person being lifted in a hoist

#### 3.4 backwards

180° to the *forwards* (3.20) direction of travel

#### 3.5 bathtub hoist

equipment specifically designed to be used in or adjacent to a bathtub for transferring by lifting and moving a person in an area limited by the system

**3.6****body-support unit**

device for providing support to a person being lifted, transferred or moved in a hoist, with its associated attachment structure

EXAMPLE A sling, seat or stretcher.

**3.7****ceiling hoist**

equipment for transferring by lifting and moving a person in a specific location by an overhead mounted system fixed to the ceiling or wall(s), including the tracking system

**3.8****central suspension point****CSP**

reference point on the hoist to be used for measurements

Note 1 to entry: This point may be a connecting point.

**3.9****connecting point**

part to which the *body-support unit* (3.6) attaches

**3.10****control device**

part or parts of the hoist that operate the lifting and lowering mechanisms of the *central suspension point* (3.8) as well as other functions

EXAMPLE The leg opening of the mobile base.

**3.11****disposable non-rigid body-support unit**

*non-rigid body-support unit* (3.34) that is not intended to be washable or cleanable and that is designed to be used by only one person

**3.12****end-limiting device**

device that stops any movement at a predetermined end position

**3.13****field of application 1**

intensive/critical care provided in a hospital where 24 h medical supervision and constant monitoring is required, and provision of life support system/equipment used in medical procedures is essential to maintain or improve the vital functions of the *person with disability* (3.36)

Note 1 to entry: Hoists used in medical procedures are often provided to help maintain or improve these functions.

**3.14****field of application 2**

acute care provided in a hospital or other medical facility where medical supervision and monitoring is required

Note 1 to entry: Hoists used in medical procedures are often provided to help maintain or improve the condition of the person with disability.

### 3.15

#### field of application 3

long-term care in a medical area where medical supervision is required, and monitoring is provided if necessary

Note 1 to entry: Hoists used in medical procedures may be provided to help maintain or improve the condition of the person with disability.

Note 2 to entry: This includes use in nursing homes and in rehabilitation and geriatric facilities.

### 3.16

#### field of application 4

care provided in a domestic area where hoists are used to alleviate or compensate for an injury, disability or disease

Note 1 to entry: This excludes use in all other application environments (e.g. nursing homes, rehabilitation and geriatric facilities) when a hoist is purely designed for application environment 4.

### 3.17

#### field of application 5

outpatient (ambulatory) care that is provided in a hospital or other medical facility under medical supervision, where hoists are provided for the need of persons with illness, injury or disability for treatment, diagnosis or monitoring

### 3.18

#### flexible device

component along with any associated joining components that functions as a *lifting device* (3.26)

EXAMPLE A chain, tape or rope.

STANDARD PREVIEW  
(standards.iteh.ai)

### 3.19

#### footrest

part of the *body-support unit* (3.6) that provides support to the feet of the person being lifted in a hoist

ISO/FDIS 10535

<https://standards.iteh.ai/catalog/standards/sist/33316009-c1ad-4c1b-84c9-e5e81bc6167b/iso-fdis-10535>

### 3.20

#### forwards

intended direction of travel, as indicated by the manufacturer in the instructions for use

### 3.21

#### free-standing stationary hoist

equipment for transferring by lifting and moving a person in an area limited by the system with the hoist free-standing on the floor

### 3.22

#### hoisting range

vertical difference between the maximum and minimum heights of the *central suspension point* (3.8)

Note 1 to entry: See [Figure 1](#), footnote m.

### 3.23

#### hoisting reach

unimpeded horizontal distance between the structure and a vertical line through the *central suspension point* (3.8) at a given height within the *hoisting range* (3.22)

Note 1 to entry: See [Figure 1](#), footnotes a, b, c.

### 3.24

#### hoist with robotic features

hoist combining all the following techniques to stimulate, replace or assist human function or interaction in performing intended task:

— information and communication technology

- combining sensing and controlled actuation technology;
- autonomy.

Note 1 to entry: Detailed information about degree of autonomy can be found in IEC/TR 60601-4-1.

### 3.25

#### **lifting cycle**

raising and lowering of the *lifting machinery* (3.27) for the same distance in both directions

### 3.26

#### **lifting device**

means of lifting and lowering the *body-support unit* (3.6)

### 3.27

#### **lifting machinery**

device that performs the lifting function

Note 1 to entry: The lifting machinery can be a hydraulic, mechanical or electrical apparatus.

### 3.28

#### **locking gate**

device that ensures a hoist cannot move from one track to another unless both tracks are in the correct position

### 3.29

#### **locking system**

means by which the *rigid body-support unit* (3.39) is secured to the hoist

### 3.30

#### **maximum load**

greatest permissible load, excluding the *body-support unit* (3.6), that can be applied to the hoist

### 3.31

#### **mobile hoist**

equipment for transferring by lifting and freely moving a person independent of a fixed installation or other allied device

Note 1 to entry: See [Figure 1](#).

### 3.32

#### **mobile hoist for transferring a person in standing position**

equipment for transferring and repositioning a person from a sitting position into an upright standing position; the equipment can be moved around freely; the body support consists of slings, a foot support and leg or knee support

### 3.33

#### **multi-purpose hoist**

piece of equipment that can be assembled, possibly with the use of different parts, to provide a variety of operations

### 3.34

#### **non-rigid body-support unit**

device, with its associated attachment structure, that is manufactured from flexible materials and which adapts to the body shape, providing support to a person being lifted in a hoist

Note 1 to entry: Examples of connecting means include loops or clips

**3.35**

**pendant control**

handheld device, which has a functional connection to the hoist, controlling at least hoist articulations and/or movements

Note 1 to entry: Pendant controls can be wired, or wireless, and can integrate other functions, e.g. communications, radio/tv, etc.

**3.36**

**person with disability**

person with one or more impairments, one or more activity limitations, one or more participant restrictions, or a combination thereof

[SOURCE: ICF 2001, WHO]

**3.37**

**portable**

equipment intended to be moved from one location to another while being carried by one or more person

**3.38**

**powered horizontal movement**

movement that includes fully automated functions activated from a pendant, but excludes manual movement assisted by a motor.

**3.39**

**rigid body-support unit**

preformed seat or recumbent device, manufactured from rigid materials (if necessary padded), or flexible materials encased by a frame, for providing support to a person being lifted in a hoist, with its associated attachment structure

iTeh STANDARD PREVIEW

(standards.iteh.ai)

[ISO/FDIS 10535](https://standards.iteh.ai/catalog/standards/sist/33316009-c1ad-4c1b-84c9-e5e8fbc107b/iso-fdis-10535)

<https://standards.iteh.ai/catalog/standards/sist/33316009-c1ad-4c1b-84c9-e5e8fbc107b/iso-fdis-10535>

**3.40**

**single-fault condition**

condition in which a single means for reducing the risk resulting from a hazard is defective or a single abnormal condition is present

**3.41**

**sitting part**

part of the *body-support unit* (3.6) that is intended for sitting on

**3.42**

**spreader bar**

rigid construction with more than one connection point on to which the *body-support unit* (3.6) is attached

**3.43**

**stationary hoist**

piece of equipment, with which a person is lifted, transferred or moved within a pre-defined area and which is fixed to a wall, ceiling or floor or is mounted or placed in or on other allied devices, or is free-standing

**3.44**

**turning diameter**

diameter of the narrowest circle encompassing the extreme points of the hoist when it is turned 360° without being reversed

Note 1 to entry: See [Figure 1](#).

Dimensions in millimetres

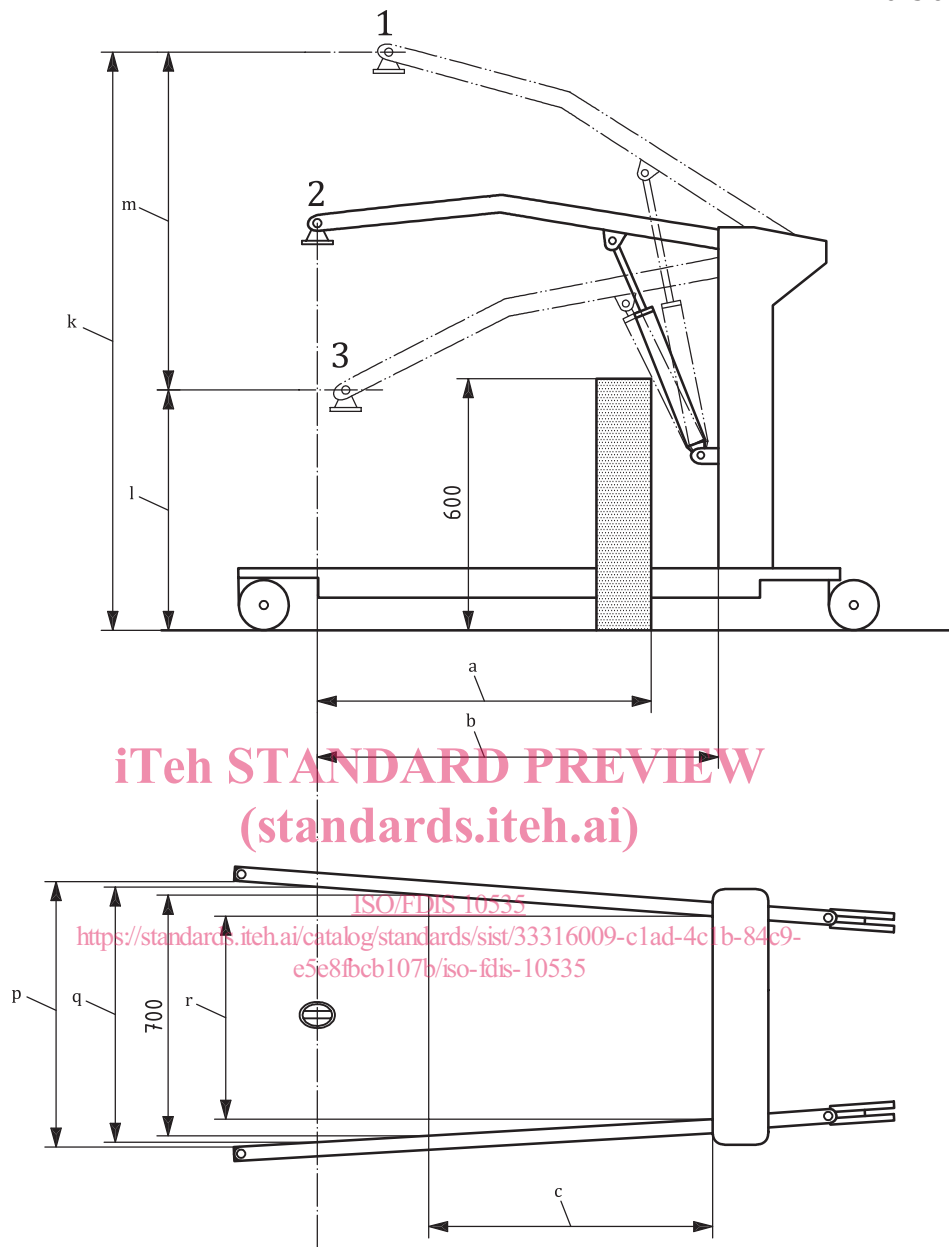

**Key**

- |   |  |   |   |
|---|--|---|---|
| 1 | highest position                                     | k | Maximum height of CSP.                    |
| 2 | maximum hoisting reach position                      | l | Minimum height of CSP.                    |
| 3 | lowest position                                      | m | Hoisting range.                           |
| a | Maximum hoisting reach at 600 mm (reference height). | p | Maximum internal width.                   |
| b | Maximum hoisting reach from base.                    | q | Internal width at maximum hoisting reach. |
| c | Hoisting reach from base with legs spread to 700 mm. | r | Minimum internal width.                   |

NOTE Example, schematic presentation only.

**Figure 1 — Key dimensions of mobile hoist**