**Welding and allied processes —
Symbolic representation on drawings
— Welded joints**

*Soudage et techniques connexes — Représentations symboliques sur
les dessins — Assemblages soudés*

iTeh Standards
(<https://standards.iteh.ai>)
Document Preview

[ISO 2553:2019](https://standards.iteh.ai/catalog/standards/iso/15df5a0e-7fd2-4167-81cf-992bc2901efd/iso-2553-2019)

<https://standards.iteh.ai/catalog/standards/iso/15df5a0e-7fd2-4167-81cf-992bc2901efd/iso-2553-2019>



iTeh Standards
(<https://standards.iteh.ai>)
Document Preview

[ISO 2553:2019](https://standards.iteh.ai/catalog/standards/iso/15df5a0e-7fd2-4167-81cf-992bc2901efd/iso-2553-2019)

<https://standards.iteh.ai/catalog/standards/iso/15df5a0e-7fd2-4167-81cf-992bc2901efd/iso-2553-2019>



COPYRIGHT PROTECTED DOCUMENT

© ISO 2019

All rights reserved. Unless otherwise specified, or required in the context of its implementation, no part of this publication may be reproduced or utilized otherwise in any form or by any means, electronic or mechanical, including photocopying, or posting on the internet or an intranet, without prior written permission. Permission can be requested from either ISO at the address below or ISO's member body in the country of the requester.

ISO copyright office
CP 401 • Ch. de Blandonnet 8
CH-1214 Vernier, Geneva
Phone: +41 22 749 01 11
Email: copyright@iso.org
Website: www.iso.org

Published in Switzerland

Contents

	Page
Foreword	v
Introduction	vi
1 Scope	1
2 Normative references	1
3 Terms and definitions	1
4 Welding symbol	5
4.1 General.....	5
4.2 Basic welding symbol.....	5
4.3 Welding symbol systems.....	6
4.4 Elementary symbols.....	6
4.4.1 General.....	6
4.4.2 Combinations of elementary symbols.....	9
4.4.3 Double-sided butt welds.....	9
4.5 Supplementary symbols.....	10
4.5.1 General.....	10
4.5.2 Weld-all-around symbol.....	13
4.5.3 Welds of the same type made from point to point.....	14
4.5.4 Field welds.....	15
4.5.5 Root reinforcement — Butt welds made from one side.....	15
4.5.6 Welds on flanged butt and flanged corner joints.....	15
4.6 Arrow line.....	17
4.6.1 General.....	17
4.6.2 Multiple arrow lines.....	17
4.6.3 Broken arrow line.....	17
4.7 Reference line and weld location.....	18
4.7.1 Reference line.....	18
4.7.2 Weld location.....	18
4.7.3 Multiple reference lines.....	19
4.8 Tail.....	20
5 Dimensioning of welds	21
5.1 General.....	21
5.2 Cross-sectional dimensions.....	21
5.3 Length dimensions.....	21
5.3.1 General.....	21
5.3.2 Intermittent welds.....	21
5.4 Butt welds.....	22
5.4.1 Penetration depth.....	22
5.4.2 Double-sided welds.....	22
5.4.3 Flanged butt welds.....	22
5.4.4 Flare bevel and flare-V butt welds.....	22
5.5 Fillet welds.....	22
5.5.1 Weld size.....	22
5.5.2 Deep penetration fillet welds.....	22
5.6 Plug welds in circular holes.....	23
5.7 Plug welds in elongated holes (slots).....	23
5.8 Spot welds.....	23
5.9 Seam welds.....	23
5.10 Edge welds.....	23
5.11 Stud welds.....	23
5.12 Overlay welds.....	24
5.13 Stake welds.....	24
6 Dimensioning of joint preparations	37

6.1	General.....	37
6.2	Root gap.....	37
6.3	Included angle.....	37
6.4	Root radius and depth of root faces — U and J butt joints.....	38
6.5	Depth of joint preparation.....	38
6.6	Countersink angle for plug welds.....	39
7	Alternative butt weld symbol with required weld quality.....	39
7.1	General.....	39
7.2	Example.....	40
Annex A (informative) Examples of the use of welding symbols.....		41
Annex B (informative) Tolerances and transition points for weld types.....		51
Annex C (informative) Alternative methods for designating intermittent butt and fillet welds.....		52
Bibliography.....		55

iTeh Standards
(<https://standards.iteh.ai>)
Document Preview

[ISO 2553:2019](https://standards.iteh.ai/catalog/standards/iso/15df5a0e-7fd2-4167-81cf-992bc2901efd/iso-2553-2019)

<https://standards.iteh.ai/catalog/standards/iso/15df5a0e-7fd2-4167-81cf-992bc2901efd/iso-2553-2019>

Foreword

ISO (the International Organization for Standardization) is a worldwide federation of national standards bodies (ISO member bodies). The work of preparing International Standards is normally carried out through ISO technical committees. Each member body interested in a subject for which a technical committee has been established has the right to be represented on that committee. International organizations, governmental and non-governmental, in liaison with ISO, also take part in the work. ISO collaborates closely with the International Electrotechnical Commission (IEC) on all matters of electrotechnical standardization.

The procedures used to develop this document and those intended for its further maintenance are described in the ISO/IEC Directives, Part 1. In particular, the different approval criteria needed for the different types of ISO documents should be noted. This document was drafted in accordance with the editorial rules of the ISO/IEC Directives, Part 2 (see www.iso.org/directives).

Attention is drawn to the possibility that some of the elements of this document may be the subject of patent rights. ISO shall not be held responsible for identifying any or all such patent rights. Details of any patent rights identified during the development of the document will be in the Introduction and/or on the ISO list of patent declarations received (see www.iso.org/patents).

Any trade name used in this document is information given for the convenience of users and does not constitute an endorsement.

For an explanation of the voluntary nature of standards, the meaning of ISO specific terms and expressions related to conformity assessment, as well as information about ISO's adherence to the World Trade Organization (WTO) principles in the Technical Barriers to Trade (TBT) see www.iso.org/iso/foreword.html.

This document was prepared by Technical Committee ISO/TC 44, *Welding and allied processes*, Subcommittee SC 7, *Representation and terms*.

Any feedback, question or request for official interpretation related to any aspect of this document should be directed to the Secretariat of ISO/TC 44/SC 7 via your national standards body. A complete listing of these bodies can be found at www.iso.org/members.html. Official interpretations, where they exist, are available from this page: <https://committee.iso.org/sites/tc44/home/interpretation.html>.

This fifth edition cancels and replaces the fourth edition (ISO 2553:2013), which has been technically revised. The main changes compared to the previous edition are as follows:

- editorial corrections especially to align with other ISO/TC 44 standards and terminology;
- figures updated to more accurately reflect welds illustrated;
- plug welds in circular and elongated holes (slots) — clarification especially as it relates to slot welds;
- old Figure 5 is now shown as [Table 5](#) for clarity;
- [Clause 6](#) has been revised to reflect Pacific Rim practices.

This corrected version of ISO 2553:2019 incorporates the following corrections:

- in [3.1](#) and [3.2](#), a cross reference to tail ([3.5](#)) has been added;
- in [Table 6](#), item 1.2, the placement of the illustration and the symbol has been corrected by moving the respective figures to the appropriate columns;
- in the NOTE to [Figure 7](#), the sentence "For system B, the dashed line is to be omitted." has been deleted;
- in [Table A.2](#), figures have been revised according to ISO 128-40.

Introduction

The symbols given in this document can be used on technical drawings for welded components. Design-related specifications, such as type, thickness, and length of weld, weld quality, surface treatment, filler material and testing specifications, can be indicated directly at the weld by means of the symbols. The principals of this document can be applied to brazed and soldered joints.

Clarity can be improved by references to collective information in the drawings or references to additional design-related documents.

Preparation for production can require detailed welding-related planning. The type of representation described in this document can be used for this purpose and complemented by additional production-related information (e.g. welding position, welding process, WPS, joint preparation, preheating). This information is often given in production-related documents, such as work schedules or welding procedure specifications (WPS).

Technical drawings are intended to clearly and understandably illustrate design-related specifications. Welding-related drawings are prepared and checked by specially trained personnel (see ISO 14731).

This document recognizes that there are two different approaches in the global market to designate the arrow side and other side on drawings, and allows for either to be used in isolation, to suit a particular market need. Application of either approach identifies a welding symbol in accordance with this document. The approach in accordance with system A is based on ISO 2553:1992¹⁾. The approach in accordance with system B is based upon standards used by Pacific Rim countries.

iteh Standards
(<https://standards.iteh.ai>)
Document Preview

[ISO 2553:2019](https://standards.iteh.ai/catalog/standards/iso/15df5a0e-7fd2-4167-81cf-992bc2901efd/iso-2553-2019)

<https://standards.iteh.ai/catalog/standards/iso/15df5a0e-7fd2-4167-81cf-992bc2901efd/iso-2553-2019>

1) Withdrawn.

Welding and allied processes — Symbolic representation on drawings — Welded joints

1 Scope

This document defines the rules to be applied for symbolic representation of welded joints on technical drawings. This can include information about the geometry, manufacture, quality and testing of the welds. The principles of this document can also be applied to soldered and brazed joints.

It is recognized that there are two different approaches in the global market to designate the arrow side and other side on drawings. In this document:

- clauses, tables and figures which carry the suffix letter "A" are applicable only to the symbolic representation system based on a dual reference line;
- clauses, tables and figures which carry the suffix letter "B" are applicable only to the symbolic representation system based on a single reference line;
- clauses, tables and figures which do not have the suffix letter "A" or "B" are applicable to both systems.

The symbols shown in this document can be combined with other symbols used on technical drawings, for example to show surface finish requirements.

An alternative designation method is presented which can be used to represent welded joints on drawings by specifying essential design information such as weld dimensions, quality level, etc. The joint preparation and welding process(es) are then determined by the production unit in order to meet the specified requirements.

NOTE Examples given in this document, including dimensions, are illustrative only and are intended to demonstrate the proper application of principles.

2 Normative references

The following documents are referred to in the text in such a way that some or all of their content constitutes requirements of this document. For dated references, only the edition cited applies. For undated references, the latest edition of the referenced document (including any amendments) applies.

ISO 128 (all parts), *Technical drawings — General principles of presentation*

ISO 129-1, *Technical product documentation (TPD) — Presentation of dimensions and tolerances — Part 1: General principles*

ISO 3098-2, *Technical product documentation — Lettering — Part 2: Latin alphabet, numerals and marks*

ISO 4063, *Welding and allied processes — Nomenclature of processes and reference numbers*

ISO/TR 25901 (all parts), *Welding and related processes — Vocabulary*

3 Terms and definitions

For the purposes of this document, the terms and definitions given in ISO/TR 25901 (all parts) and the following apply.

ISO and IEC maintain terminological databases for use in standardization at the following addresses:

- ISO Online browsing platform: available at <https://www.iso.org/obp>
- IEC Electropedia: available at <https://www.electropedia.org/>

3.1
welding symbol
symbol consisting of an *arrow line* (3.3) and a *reference line* (3.4) and which can also include *elementary symbols* (3.8) and *supplementary symbols* (3.9), dimensions and/or *tail* (3.5), used on technical drawings

Note 1 to entry: See [Clause 4](#).

3.2
basic welding symbol
symbol consisting of an *arrow line* (3.3), *reference line* (3.4) and *tail* (3.5) used when the joint is not specified and only to indicate that a welded joint is to be made

Note 1 to entry: See [4.2](#).

3.3
arrow line
leader line used to indicate that the joint is to be welded generally drawn at 135° to the *reference line* (3.4)

Note 1 to entry: See [4.6](#).

3.4
reference line
part of the *welding symbol* (3.1) on which the *elementary symbol* (3.8) is located, generally drawn parallel to the bottom edge of the drawing

Note 1 to entry: See [4.7](#).

3.5
tail
V-shaped element added to the end of the continuous *reference line* (3.4) away from the *arrow line* (3.3)

Note 1 to entry: See [4.8](#).

3.6
arrow side
side of the joint to which the *arrow line* (3.3) is pointing

Note 1 to entry: See [4.7.2.1](#).

3.7
other side
opposite side of the joint to the *arrow side* (3.6)

Note 1 to entry: See [4.7.2.1](#).

3.8
elementary symbol
symbol forming part of the *welding symbol* (3.1) and drawn on the *reference line* (3.4) to indicate the type of weld and joint preparation

Note 1 to entry: See [4.4](#).

3.9**supplementary symbol**

symbol used in conjunction with *elementary symbols* (3.8) to convey additional information about the joint

Note 1 to entry: See 4.5.

3.10**complementary information**

non-symbolic information, relevant to the welds being made, which may be included in the *tail* (3.5) of the *welding symbol* (3.1)

Note 1 to entry: See 4.8.

3.11**intermittent weld**

series of weld elements made at intervals along a joint

[SOURCE: ISO/TR 25901-1:2016, 2.1.6.15]

Note 1 to entry: See 5.3.2.

3.11.1**chain intermittent weld**

intermittent weld (3.11) on each side of a joint arranged so that the weld elements lie opposite one another along the joint

Note 1 to entry: These are usually fillet welds in T-joints and lap joints.

Note 2 to entry: See 5.3.2.2.

[SOURCE: ISO/TR 25901-1:2016, 2.1.6.17, modified — Note 2 to entry has been adapted.]

3.11.2**staggered intermittent weld**

intermittent weld (3.11) on each side of a joint arranged so that the weld elements on one side lie opposite the spaces on the *other side* (3.7) along the joint

Note 1 to entry: These are usually fillet welds in T-joints and lap joints.

Note 2 to entry: See 5.3.2.3.

[SOURCE: ISO/TR 25901-1:2016, 2.1.6.16, modified — Note 2 to entry has been adapted.]

3.12**offset**

distance between the start of welding on one side of a *staggered intermittent weld* (3.11.2) and the start of welding on the *other side* (3.7)

Note 1 to entry: See 5.3.2.3, C.2.3, Table C.1, No. 3, C.3.3 and Table C.2, No. 3.

3.13**back run**

DEPRECATED: sealing run

final run deposited on the root side of a fusion weld

[SOURCE: ISO/TR 25901-1:2016, 2.1.8.21]

3.14**backing weld**

backing in the form of a weld

3.15

nominal weld length

design length of a weld

Note 1 to entry: Nominal weld length is the length where the weld has its full size.

3.15.1

nominal length of weld element

<intermittent welds> nominal length of each element of the weld

Note 1 to entry: Nominal weld length is the length where the weld has its full size.

3.16

nominal throat thickness

a

design value of the height of the largest isosceles triangle that can be inscribed in the section of a fillet weld

Note 1 to entry: If other nominal throat thicknesses are specified, e.g. fillet welds with unequal leg lengths (see [Table 6](#), No. 2.3), they need to be clearly specified. In these cases, the symbol *a* shall not be used.

[SOURCE: ISO/TR 25901-1:2016, 2.1.7.8, modified — The symbol *a* has been added. Note 1 to entry has been changed.]

3.17

leg length

z

distance from the actual or projected intersection of the fusion faces and the toe of a fillet weld, measured across the fusion face

[SOURCE: ISO/TR 25901-1:2016, 2.1.7.5, modified — The symbol *z* has been added.]

3.18

penetration depth deposit thickness

DEPRECATED: weld metal thickness
thickness of the weld metal, excluding any reinforcement

[SOURCE: ISO/TR 25901-1:2016, 2.1.7.4]

3.19

deep penetration throat thickness

s

nominal throat thickness ([3.16](#)) or effective throat thickness to which a certain amount of fusion penetration is added

[SOURCE: ISO/TR 25901-1:2016, 2.1.7.9, modified — The symbol *s* has been added. Note 1 to entry has been deleted.]

3.20

flare-bevel weld

butt weld between a joint member with a curved surface and another with a planar surface

Note 1 to entry: See [Table 6](#), No. 1.7.

[SOURCE: ISO/TR 25901-1:2016, 2.1.6.18]

3.21

flare-V weld

butt weld between two members with curved surfaces

Note 1 to entry: See [Table 6](#), No. 1.6.

[SOURCE: ISO/TR 25901-1:2016, 2.1.6.19]

3.22

field weld

weld made outside workshops usually at the place of final installation

[SOURCE: ISO/TR 25901-1:2016, 2.1.8.40]

3.23

stake weld

weld in a T-joint where a laser beam or electron beam is irradiated from a horizontal plate/flange to vertical plate/web

Note 1 to entry: Vertical plates can be of different forms, such as corrugated panels and folded plates

4 Welding symbol

4.1 General

A reference line and arrow line are required elements. Additional elements may be included to convey specific information.

It is preferable to show the welding symbol on the same side of the joint that the weld is to be made, i.e. the arrow side (see 4.7).

The thickness of the arrow lines, reference line, elementary symbols and lettering shall be in accordance with ISO 128 (all parts) and ISO 3098-2.

In order not to overburden drawings, reference should be made to notes in the drawing or other design-related documents.

4.2 Basic welding symbol

If joint details are not specified and the only requirement is to indicate that a joint is to be welded, the basic symbol shown in Figure 1 may be used. In this case, a dual reference line is not required for system A (see 4.7.1 A) as no details concerning the weld are being conveyed.

The basic welding symbol shall comprise an arrow line, reference line and a tail.

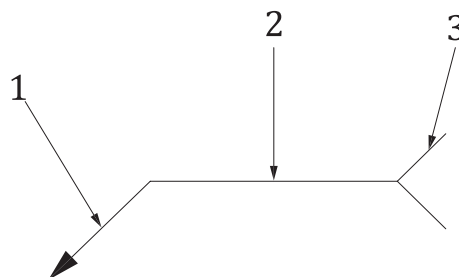

Key

- 1 arrow line
- 2 reference line
- 3 tail

NOTE This symbol is often used to indicate the location of tack welds.

Figure 1 — Basic welding symbol (joint details and type not specified)

4.3 Welding symbol systems

This document recognizes two different systems, A and B, to designate the arrow side and other side on drawings.

The symbolic representation in system A is based on a dual reference line consisting of a continuous line and a dashed line (see [4.7](#)).

The symbolic representation in system B is based on a single reference line (see [4.7](#)).

Clauses, Tables and Figures which carry the suffix "A" or "B" are applicable only to system A or system B respectively.

Clauses, tables and figures which do not have a suffix are applicable to both systems.

System A and B shall not be mixed and drawings shall clearly indicate which system is used including units of measurement in accordance with ISO 129-1.

Examples of comprehensive welding symbols showing the location of elements are given in [Figure A.1](#).

4.4 Elementary symbols

4.4.1 General

Elementary symbols, in accordance with [Table 1](#), may be added to the reference line in both systems A and B to indicate the type of weld to be made.

Elementary symbols form part of the welding symbol and shall be drawn attached to the reference line generally at the mid-point.

Elementary symbols may be complemented by:











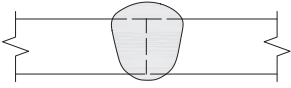

- supplementary symbols (see [4.5](#) and [Table 3](#));
- dimensions (see [Clause 5](#));
- complementary information.

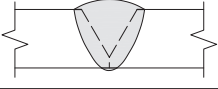
The orientation of the elementary symbols shall not be changed to that shown in [Tables 1](#) to [3](#).

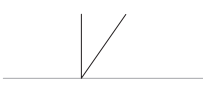
[Annex B](#) gives guidance on tolerances and transition points for butt welds, edge welds and fillet welds.

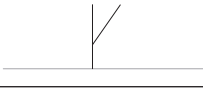
If clear illustration by means of symbols is not possible, cross-sections of the welds may be drawn and dimensioned.

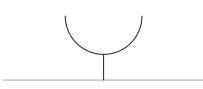
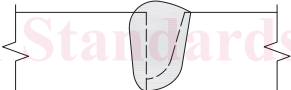
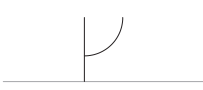
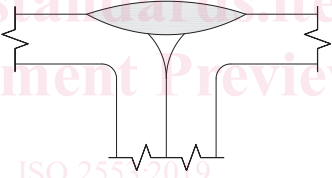
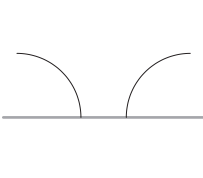
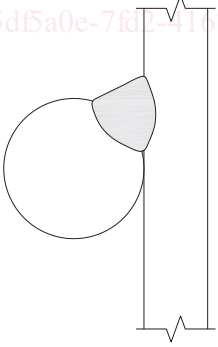
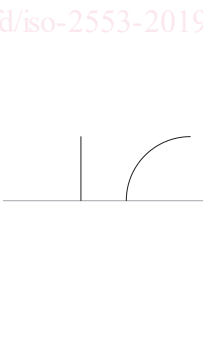
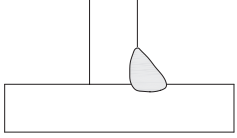
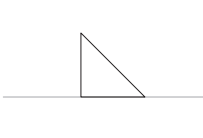
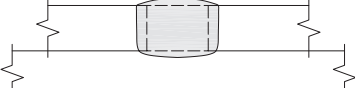
Table 1 — Elementary symbols





No.	Designation (weld type)	Illustration of weld type (dashed lines show joint preparation prior to welding)	Symbol ^a
1	Square butt ^b		
2	Single-V butt ^b		
3	Single-V butt with broad root face ^b		
4	Single-bevel butt ^b		
5	Single-bevel butt with broad root face ^b		
6	Single-U butt ^b		
7	Single-J butt ^b		
8	Flare V		
9	Flare bevel		
10	Fillet		
11	Plug		

^a The grey line is not part of the symbol. It indicates the position of the reference line.

^b Butt welds are full penetration unless otherwise indicated by dimensions on the welding symbol or by reference to other information, for example the WPS.

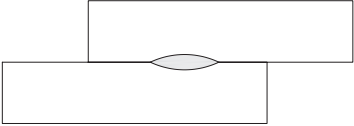
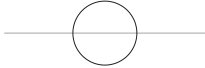
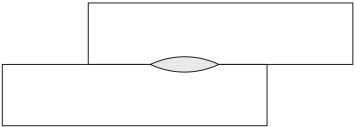
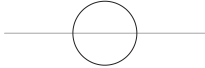
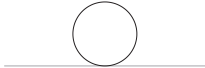
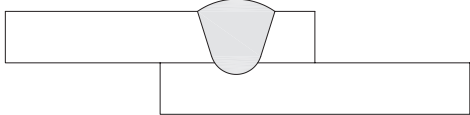
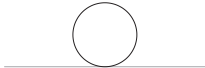
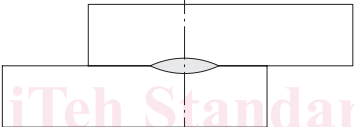
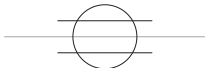
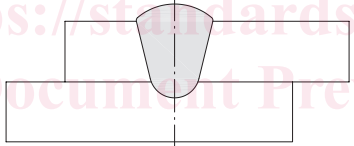
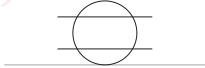
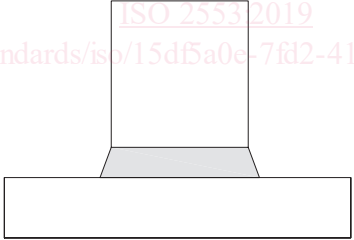
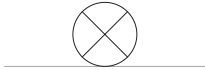
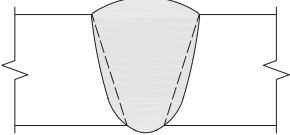
^c Symbol can also be used for joints with more than 2 members.

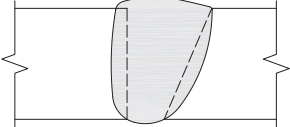
Table 1 (continued)

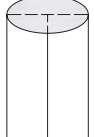
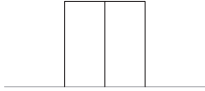
No.	Designation (weld type)	Illustration of weld type (dashed lines show joint preparation prior to welding)	Symbol ^a
12.1	Resistance spot ^c		
12.2	Projection		System A  System B 
13	Fusion spot		
14	Resistance seam ^c		
15	Fusion seam		
16	Stud		
17	Steep-flanked single-V butt ^b		
18	Steep-flanked single-bevel butt ^b		
19	Edge ^c		

^a The grey line is not part of the symbol. It indicates the position of the reference line.

^b Butt welds are full penetration unless otherwise indicated by dimensions on the welding symbol or by reference to other information, for example the WPS.

^c Symbol can also be used for joints with more than 2 members.