**Steel for the reinforcement of
concrete —**

**Part 2:
Ribbed bars**

Aciers pour l'armature du béton —

Partie 2: Barres à verrous

<https://standards.iteh.ai>
Document Preview

[ISO 6935-2:2019](https://standards.iteh.ai/catalog/standards/iso/9fc59683-1a48-4307-b9d0-fa7dcf8d74d1/iso-6935-2-2019)

<https://standards.iteh.ai/catalog/standards/iso/9fc59683-1a48-4307-b9d0-fa7dcf8d74d1/iso-6935-2-2019>



iTeh Standards
(<https://standards.iteh.ai>)
Document Preview

[ISO 6935-2:2019](https://standards.iteh.ai/catalog/standards/iso/9fc59683-1a48-4307-b9d0-fa7dcf8d74d1/iso-6935-2-2019)

<https://standards.iteh.ai/catalog/standards/iso/9fc59683-1a48-4307-b9d0-fa7dcf8d74d1/iso-6935-2-2019>



COPYRIGHT PROTECTED DOCUMENT

© ISO 2019

All rights reserved. Unless otherwise specified, or required in the context of its implementation, no part of this publication may be reproduced or utilized otherwise in any form or by any means, electronic or mechanical, including photocopying, or posting on the internet or an intranet, without prior written permission. Permission can be requested from either ISO at the address below or ISO's member body in the country of the requester.

ISO copyright office
CP 401 • Ch. de Blandonnet 8
CH-1214 Vernier, Geneva
Phone: +41 22 749 01 11
Fax: +41 22 749 09 47
Email: copyright@iso.org
Website: www.iso.org

Published in Switzerland

Contents

Page

Foreword.....	iv
1 Scope.....	1
2 Normative references.....	1
3 Terms and definitions.....	1
4 Symbols.....	3
5 Dimensions, mass per unit length and permissible deviations.....	4
6 Requirements for ribs.....	5
7 Chemical composition.....	8
8 Mechanical properties.....	10
8.1 Tensile properties.....	10
8.2 Bending properties.....	12
8.3 Rebending properties after ageing.....	12
8.4 Fatigue properties.....	12
9 Testing.....	13
9.1 Tensile test.....	13
9.2 Conditions of testing.....	13
9.3 Bend test.....	13
9.4 Rebend test.....	13
9.5 Fatigue test.....	14
9.6 Chemical composition.....	14
10 Designation.....	14
11 Marking.....	14
11.1 Marking on bars.....	14
11.2 Identification of bundles.....	15
12 Evaluation of conformity.....	15
12.1 General.....	15
12.2 Evaluation of conformity during production.....	15
12.3 Acceptance testing of a specific delivery.....	16
12.3.1 General.....	16
12.3.2 Evaluation of characteristic values.....	16
12.3.3 Evaluation of specified minimum/maximum values.....	18
12.3.4 Test report.....	18
Annex A (informative) Five examples of marking systems for ribbed bars.....	19
Annex B (informative) Options for agreement between the manufacturer and purchaser.....	24
Bibliography.....	25

Foreword

ISO (the International Organization for Standardization) is a worldwide federation of national standards bodies (ISO member bodies). The work of preparing International Standards is normally carried out through ISO technical committees. Each member body interested in a subject for which a technical committee has been established has the right to be represented on that committee. International organizations, governmental and non-governmental, in liaison with ISO, also take part in the work. ISO collaborates closely with the International Electrotechnical Commission (IEC) on all matters of electrotechnical standardization.

The procedures used to develop this document and those intended for its further maintenance are described in the ISO/IEC Directives, Part 1. In particular, the different approval criteria needed for the different types of ISO documents should be noted. This document was drafted in accordance with the editorial rules of the ISO/IEC Directives, Part 2 (see www.iso.org/directives).

Attention is drawn to the possibility that some of the elements of this document may be the subject of patent rights. ISO shall not be held responsible for identifying any or all such patent rights. Details of any patent rights identified during the development of the document will be in the Introduction and/or on the ISO list of patent declarations received (see www.iso.org/patents).

Any trade name used in this document is information given for the convenience of users and does not constitute an endorsement.

For an explanation of the voluntary nature of standards, the meaning of ISO specific terms and expressions related to conformity assessment, as well as information about ISO's adherence to the World Trade Organization (WTO) principles in the Technical Barriers to Trade (TBT) see www.iso.org/iso/foreword.html.

This document was prepared by Technical Committee ISO/TC 17, *Steel*, Subcommittee SC 16, *Steels for the reinforcement and prestressing of concrete*.

This fourth edition cancels and replaces the third edition (ISO 6935-2:2015), which has been technically revised. The main changes compared to the previous edition are as follows:

- [Figures 1, 2, 3](#) have been revised;
- [Figure 5, A.3, A.4](#) have been newly added;
- introduction of hot-rolled threaded reinforcing bar in [Clause 3, 4, 6](#) and A.7.

A list of all parts in the ISO 6935 series can be found on the ISO website.

Any feedback or questions on this document should be directed to the user's national standards body. A complete listing of these bodies can be found at www.iso.org/members.html.

Steel for the reinforcement of concrete —

Part 2: Ribbed bars

1 Scope

This document specifies technical requirements for ribbed bars to be used as reinforcement in concrete. It is applicable to steel delivered in the form of bars, coils and de-coiled products. This document covers both weldable and non-weldable steels. It does not apply to ribbed bars produced from finished products, such as plates and railway rails.

The production process is at the discretion of the manufacturer.

2 Normative references

The following documents are referred to in the text in such a way that some or all of their content constitutes requirements of this document. For dated references, only the edition cited applies. For undated references, the latest edition of the referenced document (including any amendments) applies.

ISO/TR 9769, *Steel and iron — Review of available methods of analysis*

ISO 14284, *Steel and iron — Sampling and preparation of samples for the determination of chemical composition*

ISO 15630-1, *Steel for the reinforcement and prestressing of concrete — Test methods — Part 1: Reinforcing bars, rods and wire*

ISO 6935-2:2019

<https://standards.iteh.ai/catalog/standards/iso/9fc59683-1a48-4307-b9d0-fa7dcf8d74d1/iso-6935-2-2019>

3 Terms and definitions

For the purposes of this document, the following terms and definitions apply.

ISO and IEC maintain terminological databases for use in standardization at the following addresses:

— ISO Online browsing platform: available at <https://www.iso.org/obp>

— IEC Electropedia: available at <http://www.electropedia.org/>

3.1

cast analysis

chemical analysis representative of the cast determined by the manufacturer in accordance with its own procedures

[SOURCE: ISO 16020:2005, 2.4.3, modified — “manufacturer” has replaced “steelmaker”.]

3.2

conformity assessment scheme

conformity assessment system related to specific objects of conformity assessment, to which the same specified requirements, specific rules and procedures apply

Note 1 to entry: Conformity assessment schemes may be operated at an international, national or sub-national level.

Note 2 to entry: Certification, i.e. third-party attestation related to products, processes, systems or persons, is applicable to all objects of conformity assessment except for conformity assessment bodies themselves, to which accreditation is applicable.

**3.3
characteristic value**

value having a prescribed probability of not being attained in a hypothetical unlimited test series

Note 1 to entry: Equivalent to “fractile”, which is defined in ISO 3534-1:2006.

Note 2 to entry: A nominal value is used as the characteristic value in some circumstances.

[SOURCE: ISO 16020:2005, 2.4.10, modified — Note 2 to entry has been added.]

**3.4
core**

part of the cross section of a bar containing neither ribs nor indentations

[SOURCE: ISO 16020:2005, 2.2.5, modified — “wire” has been removed from the definition.]

**3.5
ductility class**

classification of the ductility properties of ribbed reinforcing bars based on the value of the ratio of tensile strength to yield strength, as well as the elongation measured either as A_{gt} or as A

Note 1 to entry: See [Table 6](#).

**3.6
hot-rolled threaded reinforcing bar**

type of bar with threaded geometry over its entire surface with two flat parts on the longitudinal side

Note 1 to entry: This type of bar with external threads is generally connected to other threaded bars with internally threaded couplers.

**3.7
longitudinal rib**

uniform continuous rib parallel to the axis of a bar

[SOURCE: ISO 16020:2005, 2.2.7.1, modified — “wire” has been removed from the definition.]

**3.8
nominal cross-sectional area**

S_0
cross-sectional area equivalent to the area of a circular plain bar of the same nominal diameter

[SOURCE: ISO 16020:2005, 2.2.15, modified — “wire” has been removed from the definition.]

**3.9
product analysis**

chemical analysis carried out on the product

[SOURCE: ISO 16020:2005, 2.4.4]

**3.10
relative rib area**

f_R
area of the projections of all transverse ribs within a defined length on a plane perpendicular to the longitudinal axis of the bar, divided by this length and the nominal circumference

[SOURCE: ISO 16020:2005, 2.2.11, modified — “wire” has been removed from the definition.]

3.11 rib height

a

distance from the highest point on the rib to the surface of the core measured perpendicular to the axis of a bar

Note 1 to entry: See [Figure 2](#).

[SOURCE: ISO 16020:2005, 2.2.12, modified — “highest point” has replaced “one point”, “perpendicular” has replaced “normal”, “wire” has been removed from the definition and Note 1 to entry has been added.]

3.12 transverse rib spacing

c

distance between the centres of two consecutive *transverse ribs* (3.4) measured parallel to the axis of a bar

Note 1 to entry: See [Figure 1](#).

[SOURCE: ISO 16020:2005, 2.2.10, modified — “wire” has been removed from the definition.]

3.13 part of the circumference without rib

Σ_{ei}

sum of the distances along the surface of the core between the ends of the *transverse ribs* (3.4) of adjacent rows measured as the projection on a plane perpendicular to the axis of a bar

[SOURCE: ISO 16020:2005, 2.2.13, modified — “or indentationless” has been removed from the term and “or indentations” and “wire” have been removed from the definition.]

3.14 transverse rib

rib at an angle, either perpendicular or oblique, to the longitudinal axis of the bar

[SOURCE: ISO 16020:2005, 2.2.7.2, modified]

<https://standards.iteh.ai/catalog/standards/iso/91c59683-1a48-4307-b9d0-fa7dcf8d74d1/iso-6935-2-2019>

3.15 transverse rib flank inclination

α

angle between the flank of a *transverse rib* (3.4) and the core surface of a bar measured perpendicular to the longitudinal axis of the *transverse rib* (3.4)

Note 1 to entry: See [Figure 2](#).

[SOURCE: ISO 16020:2005, 2.2.9, modified — “wire” has been removed from the definition.]

3.16 transverse rib inclination

β

angle between the rib and the longitudinal axis of a bar

Note 1 to entry: See [Figures 1, 3](#) and [4](#).

[SOURCE: ISO 16020:2005, 2.2.8, modified — “wire” has been removed from the definition.]

4 Symbols

For the purposes of this document, the symbols listed in [Table 1](#) apply.

Table 1 — Symbols

Symbol	Unit	Description	Reference
a	mm	Rib height	3.11, Clause 6
A	%	Percentage elongation after fracture	8.1
A_{gt}	%	Percentage total extension at maximum force	8.1
S_0	mm ²	Nominal cross-sectional area	Clause 5, 9.1
b	mm	Top width of transverse rib at the mid-point	Clause 6
c	mm	Transverse rib spacing	3.12, Clause 6
d	mm	Nominal diameter of the bar	Clause 5, Clause 6, 9.3, 9.4, Clause 10, 11.1, 11.2,
Σ_{ei}	mm	Part of the circumference without rib	3.13, Clause 6
f_k	—	Required characteristic value	12.2, 12.3.2.3
f_R	—	Relative rib area	3.10, Clause 6
k, k'	—	Indices	12.3.2.3.1
m_n	—	Mean value of n individual values	12.3.2.3.1
n	—	Number of individual values	12.3.2.3.1
R_{eH}	MPa ^a	Upper yield strength	8.1
R_m	MPa ^a	Tensile strength	8.1
$R_{p0,2}$	MPa ^a	0,2 % proof strength, plastic extension	8.1
s_n	—	Standard deviation for n individual values	12.3.2.3.1
x_i	—	Individual value	12.3.2.3.1
α	degree	Transverse rib flank inclination	3.15, Clause 6
β	degree	Transverse rib inclination	3.16, Clause 6
T	mm	width of longitudinal flat part of hot-rolled threaded bar	Clause 6
^a 1 MPa = 1 N/mm ² .			

5 Dimensions, mass per unit length and permissible deviations

Dimensions, mass per unit length and permissible deviations are given in [Table 2](#). By agreement between the manufacturer and purchaser, ribbed bars for which the nominal diameters are other than those shown in [Table 2](#) may be used. A list of options for agreement between the manufacturer and the purchaser is provided in [Annex B](#).

Table 2 — Dimensions, mass per unit length and permissible deviations

Nominal bar diameter ^a <i>d</i> mm	Nominal cross-sectional area ^b <i>S</i> ₀ mm ²	Mass per unit length	
		Requirement ^c kg/m	Permissible deviation ^d %
6	28,3	0,222	±8
8	50,3	0,395	±8
10	78,5	0,617	±6
12	113	0,888	±6
14	154	1,21	±5
16	201	1,58	±5
20	314	2,47	±5
25	491	3,85	±4
28	616	4,84	±4
32	804	6,31	±4
40	1 257	9,86	±4
50	1 964	15,42	±4

^a Nominal diameters larger than 50 mm should be agreed between the manufacturer and purchaser. The permissible deviation on mass for such bars shall be ±4 %.

^b $S_0 = 0,785 4 \times d^2$.

^c Mass per unit length = $7,85 \times 10^{-3} \times S_0$.

^d Permissible deviation refers to a single bar.

The delivery length is subject to agreement between the manufacturer and purchaser.

NOTE Common delivery lengths of straight bars are 6 m, 9 m, 12 m and 18 m.

Unless otherwise agreed, the permissible deviation on delivery lengths from the rolling mill shall be $^{+100}_0$ mm.

6 Requirements for ribs

Ribbed bars shall have transverse ribs. Longitudinal ribs may be present or not.

There shall be at least two rows of transverse ribs equally distributed around the perimeter of the bar. The transverse ribs within each row shall be distributed uniformly over the entire length of the bar, except in the area of marking.

Ribs shall conform to the requirements given in [Table 3](#).

Table 3 — Requirements for transverse ribs

	Nominal bar diameter <i>d</i> mm	Ribs of uniform height	Crescent-shaped ribs
Rib height, <i>a</i> Minimum	All	0,03 <i>d</i>	0,03 <i>d</i>
Transverse rib spacing, <i>c</i> Range	$6 \leq d < 10$ $d \geq 10$	$0,5d \leq c \leq 0,7d$ $0,5d \leq c \leq 0,7d$	$0,5d \leq c \leq 1,0d$ $0,5d \leq c \leq 0,8d$

Table 3 (continued)

	Nominal bar diameter d mm	Ribs of uniform height	Crescent-shaped ribs
Transverse rib inclination, β	All	$35^\circ \leq \beta \leq 90^\circ$	$35^\circ \leq \beta \leq 75^\circ$
Transverse rib flank inclination, α	All	$\alpha \geq 40^\circ$	$\alpha \geq 40^\circ$
Part of the circumference without rib, Σ_{ei} Maximum	All	—	$0,25d\pi$
Top width of transverse rib at the mid-point, b Maximum	$6 \leq d < 20$ $d \geq 20$	$0,4d$ $0,2d$	$0,2d$

Requirements for rib parameters may be specified by the relative rib area, or by agreement between the manufacturer and purchaser. Measurement of rib parameters shall be performed in accordance with ISO 15630-1.

Dimensions defining the rib geometry in Table 3 are shown in Figures 1 to 5.

When longitudinal ribs are present, their height shall not exceed $0,15d$.

For transverse rib spacing of hot-rolled threaded bars, a minimum limit less than $0,5d$ may be agreed at the time of enquiry and order, but the minimum limit shall not be less than $0,35d$.

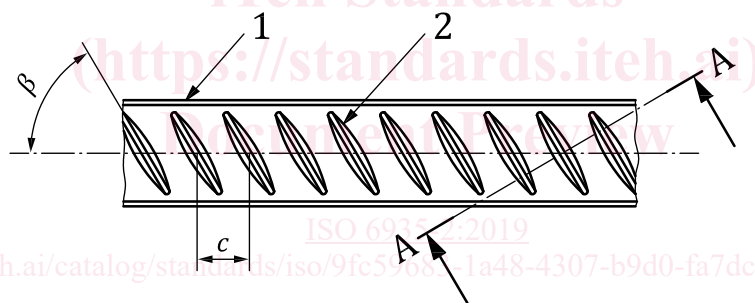

Key

- 1 longitudinal rib
- 2 transverse rib

Figure 1 — Ribbed bar — Definitions of geometry

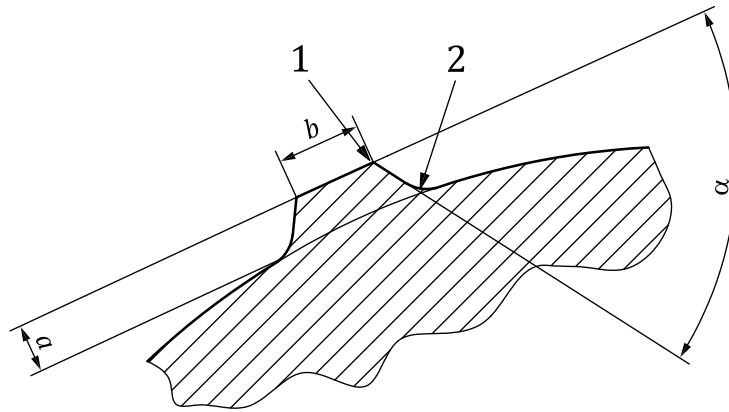

Key

- 1 rib
- 2 rounded transition

Figure 2 — Rib flank inclination, α , rib height, a , and top width of transverse rib at the midpoint, b — Section A-A from [Figure 1](#)

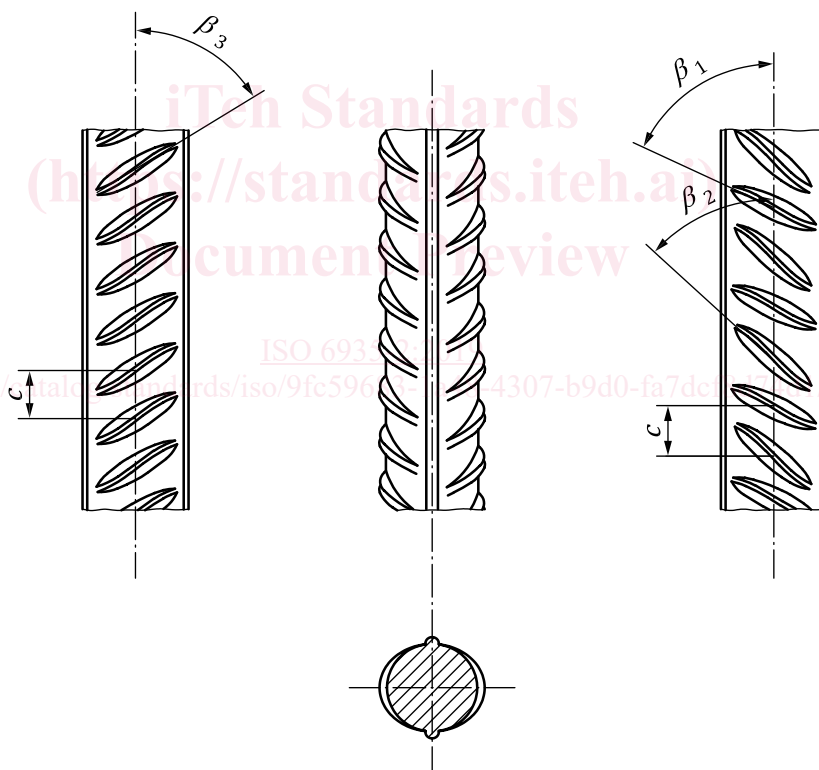

Figure 3 — Example of bar with varying rib inclinations to the longitudinal axis

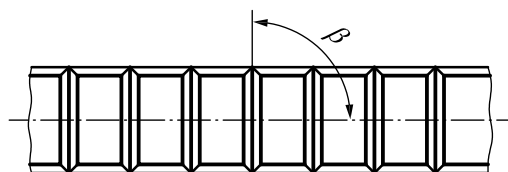

Figure 4 — Example of bar with transverse ribs of uniform height ($\beta = 90^\circ$)