

---

---

## Hardmetals — Abrasion tests for hardmetals

*Métaux-durs — Essais d'abrasion des métaux-durs*

**iTeh STANDARD PREVIEW**  
**(standards.iteh.ai)**

[ISO 28080:2021](https://standards.iteh.ai/catalog/standards/sist/3f7a8395-1578-4baa-bea3-fd8fc875ef4b/iso-28080-2021)

<https://standards.iteh.ai/catalog/standards/sist/3f7a8395-1578-4baa-bea3-fd8fc875ef4b/iso-28080-2021>



## iTeh STANDARD PREVIEW (standards.iteh.ai)

[ISO 28080:2021](https://standards.iteh.ai/catalog/standards/sist/3f7a8395-1578-4baa-bea3-fd8fc875ef4b/iso-28080-2021)

<https://standards.iteh.ai/catalog/standards/sist/3f7a8395-1578-4baa-bea3-fd8fc875ef4b/iso-28080-2021>



### **COPYRIGHT PROTECTED DOCUMENT**

© ISO 2021

All rights reserved. Unless otherwise specified, or required in the context of its implementation, no part of this publication may be reproduced or utilized otherwise in any form or by any means, electronic or mechanical, including photocopying, or posting on the internet or an intranet, without prior written permission. Permission can be requested from either ISO at the address below or ISO's member body in the country of the requester.

ISO copyright office  
CP 401 • Ch. de Blandonnet 8  
CH-1214 Vernier, Geneva  
Phone: +41 22 749 01 11  
Email: [copyright@iso.org](mailto:copyright@iso.org)  
Website: [www.iso.org](http://www.iso.org)

Published in Switzerland

# Contents

	Page
<b>Foreword</b> .....	<b>iv</b>
<b>Introduction</b> .....	<b>v</b>
<b>1 Scope</b> .....	<b>1</b>
<b>2 Normative references</b> .....	<b>1</b>
<b>3 Terms and definitions</b> .....	<b>1</b>
<b>4 Principle</b> .....	<b>2</b>
<b>5 Materials</b> .....	<b>2</b>
5.1 Test pieces.....	2
5.1.1 Overall sizes.....	2
5.1.2 Surface finish.....	2
5.2 Abrasive.....	2
5.3 Reference materials.....	2
5.4 Wheel.....	3
5.4.1 Material.....	3
5.4.2 Wheel size.....	3
<b>6 Apparatus</b> .....	<b>3</b>
6.1 Summary of apparatuses (test systems).....	3
6.2 Abrasive-feed mechanism.....	4
6.3 Vacuum extraction.....	4
6.4 Control of wheel speed.....	5
6.5 Calibration of abrasive flow.....	5
6.6 Test load.....	5
6.7 Fluid flow.....	5
6.8 Instrumentation.....	5
<b>7 Preparation of test piece</b> .....	<b>6</b>
7.1 Test-piece cleaning.....	6
7.2 Test-piece weighing.....	6
7.3 Test-sample density.....	6
<b>8 Procedure</b> .....	<b>7</b>
8.1 General.....	7
8.2 Test-piece clamping.....	7
8.3 Typical operation conditions.....	7
8.4 Start of test.....	7
8.5 End of test or test stop.....	7
8.6 Interrupted tests.....	8
8.7 Use of a reference material.....	8
8.8 Number of repeat tests.....	8
<b>9 Expression of results</b> .....	<b>8</b>
9.1 Single-step test.....	8
9.2 Multiple-step test.....	8
9.2.1 Tabulation.....	8
9.2.2 Calculation of abrasion rate.....	9
9.3 Illustration of trends of wear, friction force and normal force.....	9
9.4 Illustration of comparative set of measurements using two abrasion materials.....	9
<b>10 Uncertainty of measurement</b> .....	<b>10</b>
<b>11 Test report</b> .....	<b>11</b>
<b>Bibliography</b> .....	<b>13</b>

## Foreword

ISO (the International Organization for Standardization) is a worldwide federation of national standards bodies (ISO member bodies). The work of preparing International Standards is normally carried out through ISO technical committees. Each member body interested in a subject for which a technical committee has been established has the right to be represented on that committee. International organizations, governmental and non-governmental, in liaison with ISO, also take part in the work. ISO collaborates closely with the International Electrotechnical Commission (IEC) on all matters of electrotechnical standardization.

The procedures used to develop this document and those intended for its further maintenance are described in the ISO/IEC Directives, Part 1. In particular, the different approval criteria needed for the different types of ISO documents should be noted. This document was drafted in accordance with the editorial rules of the ISO/IEC Directives, Part 2 (see [www.iso.org/directives](http://www.iso.org/directives)).

Attention is drawn to the possibility that some of the elements of this document may be the subject of patent rights. ISO shall not be held responsible for identifying any or all such patent rights. Details of any patent rights identified during the development of the document will be in the Introduction and/or on the ISO list of patent declarations received (see [www.iso.org/patents](http://www.iso.org/patents)).

Any trade name used in this document is information given for the convenience of users and does not constitute an endorsement.

For an explanation of the voluntary nature of standards, the meaning of ISO specific terms and expressions related to conformity assessment, as well as information about ISO's adherence to the World Trade Organization (WTO) principles in the Technical Barriers to Trade (TBT), see [www.iso.org/iso/foreword.html](http://www.iso.org/iso/foreword.html).

This document was prepared by Technical Committee ISO/TC 119, *Powder metallurgy*, Subcommittee SC 4, *Sampling and testing methods for hardmetals*, in collaboration with the European Committee for Standardization (CEN) Technical Committee CEN/SS M11, *Powder metallurgy*, in accordance with the Agreement on technical cooperation between ISO and CEN (Vienna Agreement).

This second edition cancels and replaces the first edition (ISO 28080:2011), which has been technically revised.

The main changes compared to the previous edition are as follows:

- [Clause 2](#), the normative references have been updated;
- [Clauses 3](#) and [4](#) have been switched;
- [5.4.1](#), second sentence: "or neoprene" has been added.

Any feedback or questions on this document should be directed to the user's national standards body. A complete listing of these bodies can be found at [www.iso.org/members.html](http://www.iso.org/members.html).

## Introduction

This document provides new and improved methods for testing the abrasion characteristics of hardmetals using rotating-wheel systems. There are a number of abrasion test methods that have been developed that use this type of geometry, including the ASTM G65 dry sand/rubber wheel test, the ASTM G105 wet sand/rubber wheel test and the ASTM B611 steel wheel test. Other variants of these tests have also been developed for specific applications in other institutes. All of these tests use a rotating wheel pressed against a test piece, with abrasive material introduced between the wheel and the test piece. Because of this fundamental commonality, much of the methodology is the same for the different tests. However, they do differ in the details of how the abrasive is fed to the interface between the wheel and the test piece, if the test can be carried out in the presence of fluids, and if the abrasive is only used once and passes through the test system, or is reused many times.

This document provides framework that brings together the key features of these tests and gives results that show comparability. It also gives information on their reproducibility and repeatability.

The procedure complements the ASTM G65 method for dry sand/rubber wheel abrasion, the ASTM B611 method for determining the high stress abrasion of hard materials, and the ASTM G105 method for conducting wet sand/rubber wheel abrasion tests.

Abrasion wear is not a measure of the wear characteristics of hardmetals under all conditions, and should not be misinterpreted as indicating wear when hardmetals are used for tooling, such as cutting and milling. It does show the difference in resistance to abrasive use for different carbide compositions, and the methods may be used as practical tests or as research methods for material discrimination.

**iTeh STANDARD PREVIEW**  
**(standards.iteh.ai)**

[ISO 28080:2021](https://standards.iteh.ai/catalog/standards/sist/3f7a8395-1578-4baa-bea3-fd8fc875ef4b/iso-28080-2021)

<https://standards.iteh.ai/catalog/standards/sist/3f7a8395-1578-4baa-bea3-fd8fc875ef4b/iso-28080-2021>

**iTeh STANDARD PREVIEW**  
**(standards.iteh.ai)**

ISO 28080:2021

<https://standards.iteh.ai/catalog/standards/sist/3f7a8395-1578-4baa-bea3-fd8fc875ef4b/iso-28080-2021>

# Hardmetals — Abrasion tests for hardmetals

## 1 Scope

This document specifies a generic test method to determine the abrasion wear characteristics of hardmetals.

The test is appropriate for use in situations where test laboratories have a need to simulate abrasive damage. The procedure includes information which enables the test to be used in a variety of different conditions:

- a) with counterface wheels of different stiffness (for example steel and rubber);
- b) wet and dry;
- c) different abrasive sizes;
- d) different chemical environments.

## 2 Normative references

The following documents are referred to in the text in such a way that some or all of their content constitutes requirements of this document. For dated references, only the edition cited applies. For undated references, the latest edition of the referenced document (including any amendments) applies.

ISO 3369, *Impermeable sintered metal materials and hardmetals — Determination of density*

ASTM B611, *Standard Test Method for Determining the High Stress Abrasion Resistance of Hard Materials*

ASTM G65, *Standard Test Method for Measuring Abrasion Using the Dry Sand/Rubber Wheel Apparatus*

ASTM G105, *Standard Test Method for Conducting Wet Sand/Rubber Wheel Abrasion Tests*

## 3 Terms and definitions

For the purposes of this document, the following terms and definitions apply.

ISO and IEC maintain terminological databases for use in standardization at the following addresses:

- ISO Online browsing platform: available at <https://www.iso.org/obp>
- IEC Electropedia: available at <http://www.electropedia.org/>

### 3.1

#### abrasion volume loss

$V$

test piece's loss in volume during the test

Note 1 to entry: In ASTM B611, this is defined as the volume loss per revolution of the steel wheel.

### 3.2

#### abrasion wear

wear caused by an abrasive material on a rotating surface contacting the test-piece surface under pressure

## 4 Principle

The test uses a rotating wheel against which test pieces are pressed. Abrasive is introduced between the wheel and the test piece to cause abrasion to the test piece.

## 5 Materials

### 5.1 Test pieces

#### 5.1.1 Overall sizes

Test pieces are typically larger than the contact area with the rotating wheel and are typically 40 mm to 70 mm × 20 mm to 25 mm in size. These test pieces are designed to allow for the wear scar to be contained wholly within the area of the contact face. However, some variants of the test (see Reference [1]) use a test piece with a clearly defined contact shape and size where the wear takes place across the entire contact face of the sample. The thickness of the test piece is not important, as long as it is sufficiently robust and the wear takes place entirely within the test piece.

When coated samples are tested, the test duration is normally adjusted to ensure that the wear occurs exclusively within the coating. This can be determined by post-test examination.

#### 5.1.2 Surface finish

The surface finish of the test piece can affect the results of the test. Thus, the presence of a surface that is weakened by the preparation process can lead to increased initial wear. Conversely, the presence of a residual compressive stress in the surface layer can possibly reduce initial wear. In both cases when these surface regions are worn away, the wear rate is expected to approach the normal value for the material.

ISO 28080:2021

<https://standards.iteh.ai/catalog/standards/sist/3f7a8395-1578-4baa-bea3-fd8fc875ef4b/iso-28080-2021>

### 5.2 Abrasive

The test abrasive shall be obtained from a consistent source with good quality control procedures, to ensure that variability in its properties is minimized.

It is well known that the results of abrasion testing depend critically on the shape, size and size distribution of the abrasive. For this reason, if it is important to compare the results of one test with another, the same abrasive should be used in the tests concerned.

It is important that the abrasive be dry and free flowing to avoid blockage of the test system. The moisture content of the abrasive should be less than 1 % by mass. The moisture content can be measured by weighing a sample, heating to 105 °C for an hour, cooling in a desiccator, and reweighing. The percent mass loss is assumed to be moisture. If necessary, it should be dried in an oven before use.

ASTM B611 uses coarse alumina as an abrasive, and ASTM G65 and ASTM G105 use silica sand. For further specific details of the abrasives, see ASTM B611, ASTM G65 and ASTM G105.

### 5.3 Reference materials

It is also effective, in some circumstances, to use a reference material in a sequence of tests to normalize test results to take account of minor uncontrolled variations in test conditions or changes in the make-up of the abrasive. This procedure is described in 8.7.

In any case, a test should be carried out periodically on a reference material to ensure that the test system is operating correctly and gives repeatable results.



## 5.4 Wheel

### 5.4.1 Material

Either the wheel is made from a solid piece of the requisite material such as steel, or, when elastomeric materials are being used to provide a compliant surface, a rim of the necessary elastomer is normally moulded onto the rim of a steel wheel. Suitable wheels of AISI 1020 grade steel as specified in ASTM B611 and chlorobutyl rubber or neoprene rimmed wheels with a Shore A Durometer hardness as specified in ASTM G65 or in ASTM G105 shall be used.

Moulded polyurethane or other artificial elastomer rims may also be used, but it should be noted that, even if the same ambient temperature hardness is achieved for the polyurethane as for the above-specified rubber, significant differences in results can occur in dry tests, possibly due to alteration of mechanical properties relative to those of the rubber due to heating by the abrasion process.

### 5.4.2 Wheel size

The wheel specified in ASTM G65 has a diameter of 228,6 mm and a face width of 12,7 mm and in ASTM B611 it has a maximum diameter of 169 mm and width of 12,7 mm. There are other test systems of a similar type which have wheels of different size, but unless there are special reasons to choose otherwise, the specific test conditions in the ASTM standards should be used. For tests which use rubber elastomer rims, such as ASTM G65, the thickness of the rim should be 12,7 mm. Again, if there are no special reasons to choose otherwise, the ASTM G65 conditions should be used.

The wheel is subjected to damage during the testing and should be checked periodically. If significant damage has occurred, the wheel should be replaced. The overall diameter of the wheel should also be checked and, when it is reduced in size by the recommended amount (12,7 mm for ASTM G65 and 4 mm for ASTM B611), the wheel should be replaced.

The rubber wheel should be dressed accordingly before each test.

The flatness and squareness of the contact area on the wheel are most easily checked by examining a wear scar (see [Figure 3](#)). If this is even and regular, then the contact is flat and square.

## 6 Apparatus

### 6.1 Summary of apparatuses (test systems)

The schematics of typical test systems are shown in [Figure 1](#). Two variants are shown, Variant 1 (see References [2] and [3]) where the test piece is horizontal and pressed into the top of the wheel, and Variant 2 (see Reference [4]) where the test piece is held vertically and pressed into the edge of the wheel.

NOTE Examples of Variant 2 test systems are the ASTM B611 test and the ASTM G65 test.

The abrasive is fed from a hopper into the abrasive-feed system and thence into the contact between the test piece and rotating wheel.

The test conditions can also be varied by adding a supply of fluid just in front of the abrasive feed, or by immersing the wheel in a bath of fluid that wets the wheel.

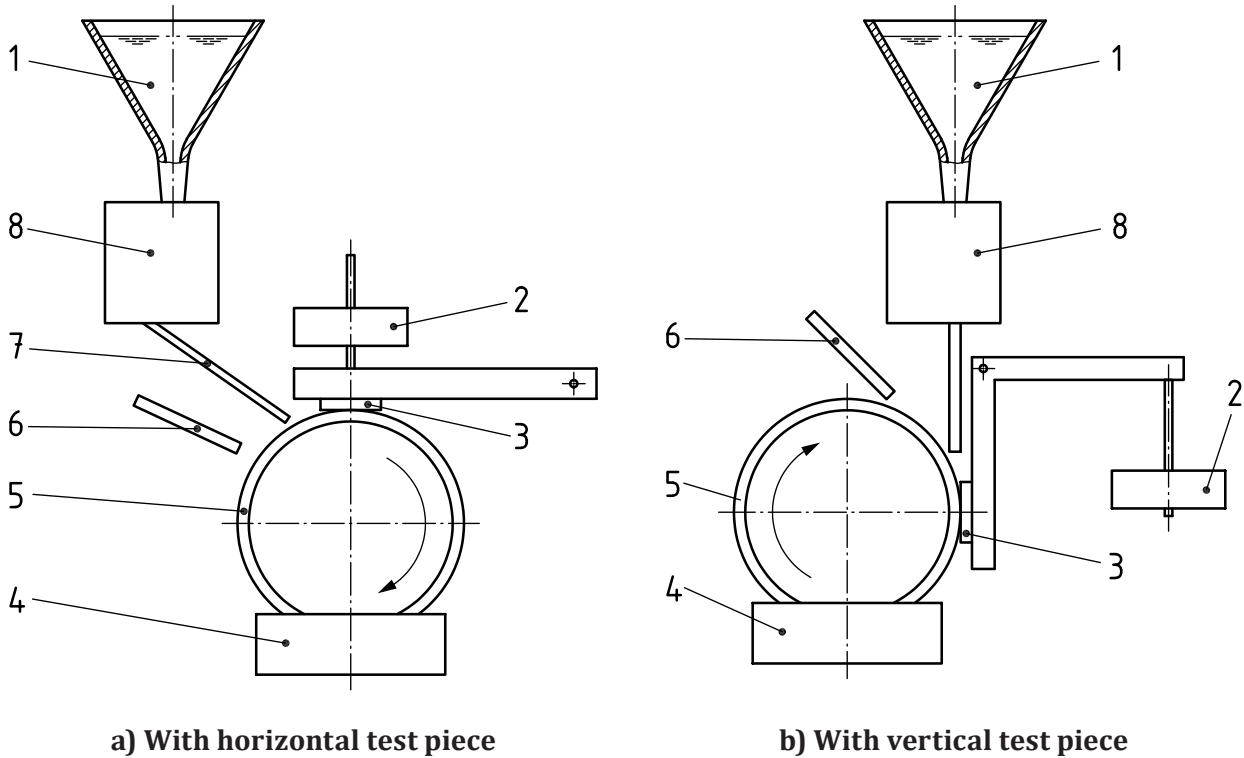

**iTeh STANDARD PREVIEW**  
(standards.iteh.ai)

**Key**

- |   |             |   |                         |
|---|-------------|---|-------------------------|
| 1 | abrasive    | 5 | rubber rim              |
| 2 | weight      | 6 | fluid feed              |
| 3 | sample      | 7 | feed chute              |
| 4 | slurry bath | 8 | abrasive-feed mechanism |

NOTE Abrasive can be fed by means of a slurry bath or by means of an abrasive feed from a hopper. Both types of supply are not required. In addition, the fluid is not required for dry tests.

**Figure 1 — Schematic diagram of rotating-wheel abrasion test system with horizontal test piece or vertical test piece**

**6.2 Abrasive-feed mechanism**

The abrasive can be fed to the test piece, respectively wheel interface, by a number of different methods. These include

- a) a vibrating feed,
- b) a screw auger, and
- c) a slotted rotating disc to control flow coupled with a chute.

The essential feature of all these methods is that the abrasive is fed steadily and in a well-controlled way to the test piece, respectively wheel interface. All of these methods have been shown to be effective in giving good control of feed rates.

**6.3 Vacuum extraction**

It is important that, for dry tests, a vacuum extraction system with the appropriate HSE filters be fitted to ensure that any used fine debris from the abrasive test piece that can be a health risk is collected and can subsequently be disposed of safely.

## 6.4 Control of wheel speed

The wheel speed needs to be well controlled with a motor of adequate power such that a stable constant speed is achieved independent of the load applied. The rotational speed shall be calibrated periodically (once per year is recommended) to ensure stable operation.

## 6.5 Calibration of abrasive flow

The abrasive flow is clearly a critical parameter in the testing. This needs to be carefully measured. It is important to ensure that only the abrasive that actually passes through the wearing contact is measured. This is normally achieved by arranging a series of baffles to divert away any abrasive that does not pass through the contact, so that only the abrasive that does pass through is measured by collecting and weighing for a pre-determined period and calculating a rate of abrasive flowrate.

Some test systems (see References [1] and [5]) are specifically designed to ensure that all the abrasive passes through the test contact. In these systems, the abrasive flow rate can be calculated by a simple measurement of all the abrasive passing through the contact.

To enable a comparison of abrasion loading to be carried out from one rig to another, the abrasive flowrate can be converted to an abrasive coverage figure with [Formula \(1\)](#).

$$C_a = \frac{Q}{A_c} \quad (1)$$

where

$C_a$  is the abrasive coverage figure, in cubic metres per square metre seconds ( $\text{m}^3 \text{m}^{-2} \text{s}^{-1}$ );

$Q$  is the volume flowrate, in cubic metres per second ( $\text{m}^3 \text{s}^{-1}$ );

$A_c$  is the abrasive coverage, in square metres ( $\text{m}^2$ ).

This procedure is only useful where the counterface is compliant, so that the contact area does not increase markedly as wear takes place during the test.

## 6.6 Test load

Normally, dead-weight loading is applied through a lever-arm system. However, other types of loading system can be used effectively. The actual load applied should be calibrated before use of the test system and should be checked periodically (typically once per year or every 200 tests).

## 6.7 Fluid flow

In systems fitted with a fluid feed, the flowrate shall be calibrated before use. This is normally done by simple gravimetric procedures.

## 6.8 Instrumentation

Some test systems used to carry out abrasion tests on hardmetals are instrumented to measure and store other test results, such as the friction force ( $F_F$ ), normal force ( $F_N$ ), and depth of wear ( $D$ ), during the test run. Acquisition of measured values is carried out by means of appropriate signal conditioning, an analogue-to-digital converter, and a personal computer.  $F_F$  is measured by a suitably mounted load cell,  $F_N$  is measured by a load cell integrated in the lever arm, and  $D$  is measured by a displacement transducer placed in such a way as to monitor the movement of the test wheel into the sample.

An example of a test system that incorporates these features is shown in [Figure 2](#).