

---

---

**Rubber, vulcanized — Determination  
of low-temperature characteristics —  
Temperature-retraction procedure  
(TR test)**

*Caoutchouc vulcanisé — Détermination des caractéristiques à basse  
température — Méthode température-retrait (essai TR)*

**iTeh STANDARD PREVIEW**  
**(standards.iteh.ai)**

[ISO 2921:2019](https://standards.iteh.ai/catalog/standards/sist/fabfdb9a-b75d-4126-b938-62b1d80a53af/iso-2921-2019)

[https://standards.iteh.ai/catalog/standards/sist/fabfdb9a-b75d-4126-b938-  
62b1d80a53af/iso-2921-2019](https://standards.iteh.ai/catalog/standards/sist/fabfdb9a-b75d-4126-b938-62b1d80a53af/iso-2921-2019)



**iTeh STANDARD PREVIEW**  
**(standards.iteh.ai)**

ISO 2921:2019

<https://standards.iteh.ai/catalog/standards/sist/fabfdb9a-b75d-4126-b938-62b1d80a53af/iso-2921-2019>



**COPYRIGHT PROTECTED DOCUMENT**

© ISO 2019

All rights reserved. Unless otherwise specified, or required in the context of its implementation, no part of this publication may be reproduced or utilized otherwise in any form or by any means, electronic or mechanical, including photocopying, or posting on the internet or an intranet, without prior written permission. Permission can be requested from either ISO at the address below or ISO's member body in the country of the requester.

ISO copyright office  
CP 401 • Ch. de Blandonnet 8  
CH-1214 Vernier, Geneva  
Phone: +41 22 749 01 11  
Fax: +41 22 749 09 47  
Email: [copyright@iso.org](mailto:copyright@iso.org)  
Website: [www.iso.org](http://www.iso.org)

Published in Switzerland

# Contents

	Page
Foreword.....	iv
<b>1 Scope</b> .....	<b>1</b>
<b>2 Normative references</b> .....	<b>1</b>
<b>3 Terms and definitions</b> .....	<b>1</b>
<b>4 Principle</b> .....	<b>1</b>
<b>5 Apparatus</b> .....	<b>1</b>
<b>6 Calibration</b> .....	<b>4</b>
<b>7 Test pieces</b> .....	<b>4</b>
7.1 Preparation.....	4
7.2 Types.....	4
7.2.1 Standard test piece.....	4
7.2.2 Test pieces cut from products.....	4
7.3 Number of test pieces.....	4
7.4 Conditioning.....	5
<b>8 Procedure</b> .....	<b>5</b>
<b>9 Expression of results</b> .....	<b>6</b>
<b>10 Precision</b> .....	<b>6</b>
<b>11 Test report</b> .....	<b>6</b>
<b>Annex A (normative) Calibration schedule</b> .....	<b>8</b>
<b>Annex B (informative) Precision</b> .....	<b>10</b>
<b>Bibliography</b> .....	<b>13</b>

## Foreword

ISO (the International Organization for Standardization) is a worldwide federation of national standards bodies (ISO member bodies). The work of preparing International Standards is normally carried out through ISO technical committees. Each member body interested in a subject for which a technical committee has been established has the right to be represented on that committee. International organizations, governmental and non-governmental, in liaison with ISO, also take part in the work. ISO collaborates closely with the International Electrotechnical Commission (IEC) on all matters of electrotechnical standardization.

The procedures used to develop this document and those intended for its further maintenance are described in the ISO/IEC Directives, Part 1. In particular the different approval criteria needed for the different types of ISO documents should be noted. This document was drafted in accordance with the editorial rules of the ISO/IEC Directives, Part 2 (see [www.iso.org/directives](http://www.iso.org/directives)).

Attention is drawn to the possibility that some of the elements of this document may be the subject of patent rights. ISO shall not be held responsible for identifying any or all such patent rights. Details of any patent rights identified during the development of the document will be in the Introduction and/or on the ISO list of patent declarations received (see [www.iso.org/patents](http://www.iso.org/patents)).

Any trade name used in this document is information given for the convenience of users and does not constitute an endorsement.

For an explanation on the voluntary nature of standards, the meaning of ISO specific terms and expressions related to conformity assessment, as well as information about ISO's adherence to the World Trade Organization (WTO) principles in the Technical Barriers to Trade (TBT) see the following URL: [www.iso.org/iso/foreword.html](http://www.iso.org/iso/foreword.html). (standards.iteh.ai)

This document was prepared by Technical Committee ISO/TC 45, *Rubber and rubber products*, Subcommittee SC 2, *Testing and analysis*. <https://standards.iteh.ai/catalog/standards/sist/fabfdb9a-b75d-4126-b938-6371f30c4d3a/iso-2921-2019>

This sixth edition cancels and replaces the fifth edition (ISO 2921:2011), which has been technically revised.

The main changes compared to the previous edition are as follows:

- In [5.8](#), a clarification has been included as for how to set the slight tension on the test pieces.
- Precision results has been added as [Annex B](#).

Any feedback or questions on this document should be directed to the user's national standards body. A complete listing of these bodies can be found at [www.iso.org/members.html](http://www.iso.org/members.html).

# Rubber, vulcanized — Determination of low-temperature characteristics — Temperature-retraction procedure (TR test)

**WARNING 1** — Persons using this document should be familiar with normal laboratory practice. This document does not purport to address all of the safety problems, if any, associated with its use. It is the responsibility of the user to establish appropriate safety and health practices and to determine the applicability of any other restrictions.

**WARNING 2** — Certain procedures specified in this document might involve the use or generation of substances, or the generation of waste, that could constitute a local environmental hazard. Reference should be made to appropriate documentation on safe handling and disposal after use.

## 1 Scope

This document specifies a method for the determination of the temperature-retraction characteristics of stretched vulcanized rubber.

This document does not cover thermoplastic rubbers, as many thermoplastic elastomers have a yield point in the range of 5 % to 20 % elongation.

## 2 Normative references (standards.iteh.ai)

The following documents are referred to in the text in such a way that some or all of their content constitutes requirements of this document. For dated references, only the edition cited applies. For undated references, the latest edition of the referenced document (including any amendments) applies.

ISO 18899:2013, *Rubber — Guide to the calibration of test equipment*

ISO 23529, *Rubber — General procedures for preparing and conditioning test pieces for physical test methods*

## 3 Terms and definitions

No terms and definitions are listed in this document.

ISO and IEC maintain terminological databases for use in standardization at the following addresses:

- ISO Online browsing platform: available at <http://www.iso.org/obp>
- IEC Electropedia: available at <http://www.electropedia.org/>

## 4 Principle

A test piece is stretched at standard laboratory temperature and then cooled to a sufficiently low temperature such that retraction does not occur upon removal of the stretching force. The stretching force is removed and the temperature increased at a uniform rate. The temperatures at which specified percentage retractions occur are determined.

## 5 Apparatus

**5.1 Retraction apparatus**, comprising the components specified in 5.2 to 5.8 (see also [Figure 1](#)).

**5.2 Heat-transfer medium**, liquid or gaseous, which remains fluid at the test temperature and which does not appreciably affect the material being tested, as prescribed in ISO 23529.

Gases may be employed as the heat-transfer medium provided the design of the apparatus is such that results obtained using them will duplicate those obtained with liquids.

The following fluids have been used satisfactorily:

a) for temperatures down to  $-60\text{ }^{\circ}\text{C}$ , silicone fluids are usually suitable owing to their chemical inertness towards rubbers, their non-flammability and their non-toxicity;

NOTE A kinematic viscosity of about  $5\text{ mm}^2/\text{s}$  at ambient temperature has been found suitable.

b) for temperatures down to  $-73\text{ }^{\circ}\text{C}$ , ethanol;

c) for temperatures down to  $-120\text{ }^{\circ}\text{C}$ , methylcyclohexane cooled by liquid nitrogen (found to be satisfactory with the use of suitable apparatus).

**5.3 Temperature-measuring device**, capable of measuring the temperature to within  $0,5\text{ }^{\circ}\text{C}$  over the whole range of temperatures over which the apparatus is to be used.

The temperature sensor shall be positioned near the test pieces.

**5.4 Temperature control**, capable of maintaining the temperature of the heat-transfer medium to within  $\pm 1\text{ }^{\circ}\text{C}$ .

iTeh STANDARD PREVIEW

**5.5 Container for the heat-transfer medium**: A bath for a liquid medium or a test chamber for a gaseous medium, with means of heating the heat-transfer medium.

**5.6 Means of agitating the heat-transfer medium**: A stirrer for liquids or a fan or blower for gases, which ensures thorough circulation of the heat-transfer medium. It is important that the stirrer also moves the liquid vertically to ensure a uniform temperature in the liquid.

**5.7 Stopwatch or other timing device**, calibrated in seconds.

**5.8 Rack with test piece holders**, equipped with a loading device, holders for one or more test pieces and a locking device for the upper (movable) test piece holders (see [Figure 1](#)).

The rack shall be designed to maintain a slight tension ( $10\text{ kPa}$  to  $20\text{ kPa}$  in air) on each test piece and to permit them to be stretched up to a maximum of  $350\%$ ; the design shall permit the upper test piece holder to be locked into position at the chosen elongation and subsequently released. Means shall be provided to enable the length of each test piece to be read, at any time during the test, with an accuracy of  $\pm 0,25\text{ mm}$  or better.

Alternatively, a series of removable scales graduated to allow the retraction to be read directly as a percentage of the elongation of the frozen rubber with an accuracy of  $\pm 0,5\%$  may be used as long as the tolerance is met.

The rack shall be designed to keep a slight tension of  $10\text{ kPa}$  to  $20\text{ kPa}$  in the liquid used.

Set the extra slight tension by having the upper test piece holder in a position in the middle of the elongation to be used and balance the holder. Then add weights to get the tension in the range of  $10\text{ kPa}$  to  $20\text{ kPa}$ . This is done at standard laboratory temperature.

NOTE The tension of the upper test piece holder is influenced of the liquid having a buoyancy effect depending of the volume of the test piece holder in the liquid.

The movable parts of the apparatus shall be constructed so that the lowest possible friction occurs.

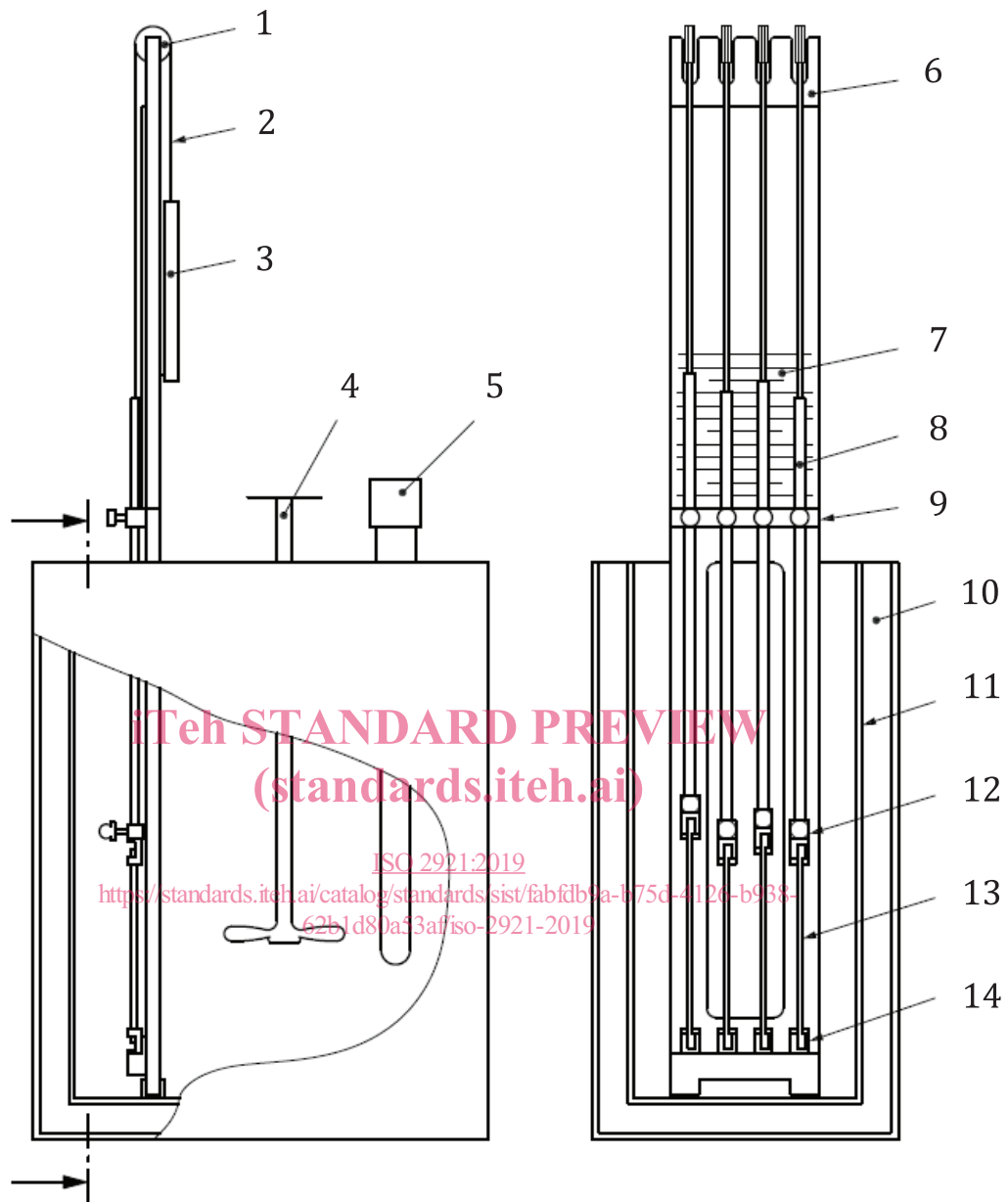

iTeh STANDARD PREVIEW  
(standards.iteh.ai)

ISO 2921:2019

<https://standards.iteh.ai/catalog/standards/sist/fbfdb9a-b75d-412d-b938-62b1d80a33af/iso-2921-2019>

**Key**

- |   |  |
|---|--|
| 1 pulley                                    | 8 upper part of upper test piece holder      |
| 2 cord                                      | 9 locking device for upper test piece holder |
| 3 counterweight                             | 10 thermal insulation                        |
| 4 stirrer                                   | 11 bath for heat-transfer medium             |
| 5 immersion heater for heat-transfer medium | 12 upper test piece holder                   |
| 6 test rack                                 | 13 test piece                                |
| 7 removable graduated scales                | 14 lower test piece holder                   |

**Figure 1 — Example of a retraction apparatus**

## 6 Calibration

The test apparatus shall be calibrated in accordance with the schedule given in [Annex A](#).

## 7 Test pieces

### 7.1 Preparation

Test pieces shall be prepared in accordance with ISO 23529.

### 7.2 Types

#### 7.2.1 Standard test piece

The standard test piece shall be a strip with enlarged ends for clamping, with dimensions in accordance with [Figure 2](#). The reference length,  $l_0$ , shall be either  $100 \text{ mm} \pm 0,2 \text{ mm}$  or  $50 \text{ mm} \pm 0,2 \text{ mm}$ . The test piece with a reference length of  $100 \text{ mm} \pm 0,2 \text{ mm}$  is preferred for tests with small elongations and the test piece with a reference length of  $50 \text{ mm} \pm 0,2 \text{ mm}$  for tests with larger elongations. Test pieces shall be cut with a sharp die from a flat sheet  $2 \text{ mm} \pm 0,2 \text{ mm}$  thick. The sheets may be prepared by moulding or from finished products by cutting and buffing.

The 50 mm test piece may be used also with 50 % elongation if the reading accuracy of the measurement system is  $\pm 0,125 \text{ mm}$  or better.

iTeh STANDARD PREVIEW

#### 7.2.2 Test pieces cut from products (standards.iteh.ai)

Alternatively, other types of test piece cut from finished rubber products may be used (for example an O-ring with a cross-sectional diameter between [1,5 mm and 4 mm](#)).

Note that such test pieces do not necessarily give the same values of retraction temperature as do the two sizes of standard test piece specified in [7.2.1](#), and comparison between the values obtained using different types of test piece should be avoided.

### 7.3 Number of test pieces

At least three test pieces shall be used for each test.

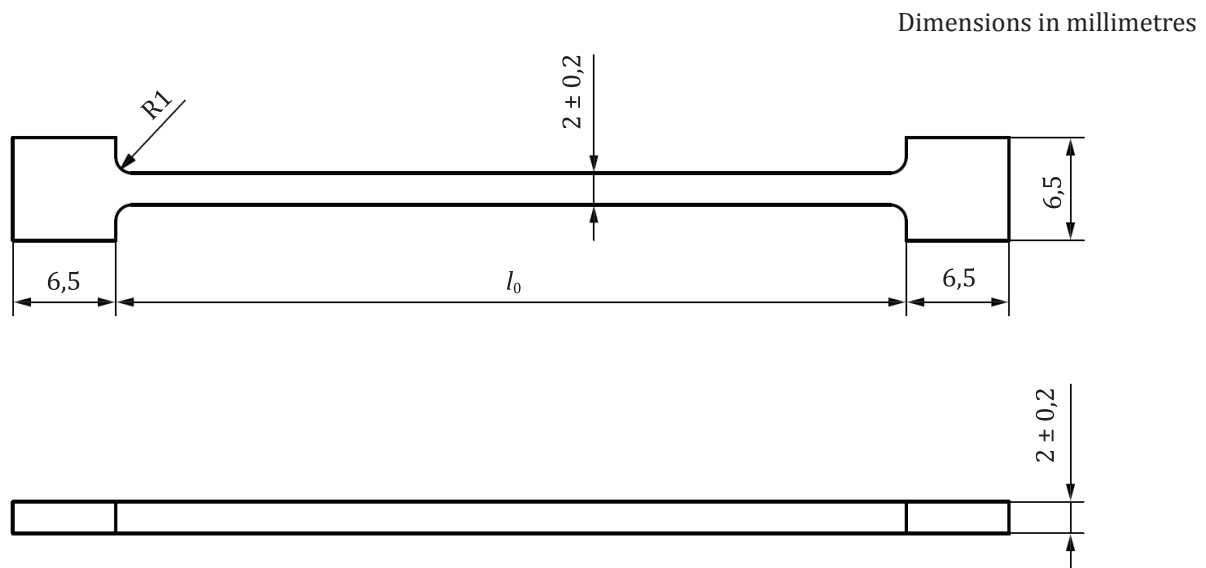

Figure 2 — Test piece



## 7.4 Conditioning

7.4.1 Unless otherwise specified for technical reasons, the procedure in 7.4.2 to 7.4.5 shall be followed.

7.4.2 The time-interval between vulcanization and testing shall be in accordance with ISO 23529.

7.4.3 Samples and test pieces shall be protected from light as completely as possible during the interval between vulcanization and testing.

7.4.4 Test pieces shall be conditioned, immediately before testing, at one of the standard laboratory temperatures specified in ISO 23529 for a minimum of 16 h.

7.4.5 If samples that are apt to crystallize are exposed to low storage temperatures before testing, crystallization that significantly affects the TR values measured can occur. If values for the material in the uncrystallized condition are desired, the test pieces shall be decrystallized before testing by heating them in an oven at 70 °C for 30 min. They shall then be conditioned at a standard laboratory temperature for at least 30 min, but not more than 60 min.

## 8 Procedure

The bath shall contain enough heat-transfer medium (5.2) to cover the test pieces with at least 25 mm of liquid during testing.

Cool the heat-transfer medium, whilst stirring, to below –70 °C as described in ISO 23529.

While the liquid is cooling, insert the test pieces in the rack (5.8) and, at the standard laboratory temperature being used, stretch each test piece from the reference length to the chosen elongation and lock it in position. Ensure that the test pieces are only kept stretched at the standard temperature for the minimum time.

The elongation shall be chosen in the light of the following criteria:

- a) provided technical reasons do not dictate otherwise, and to reduce the effect of crystallization, an elongation of 50 % shall be used;
- b) one of the following elongations shall be used to study the combined effect of crystallization and low temperature:
  - 1) 250 %,
  - 2) half the elongation at break if 250 % is unobtainable,
  - 3) 350 %, if the elongation at break is greater than 600 %.

When the heat-transfer medium has reached an equilibrium temperature between –70 °C and –73 °C, place the rack with the test pieces in the bath. Allow to stand for 10 min ± 2 min in the bath between –70 °C and –73 °C. Release the locking device for the upper holder and allow the test pieces to retract freely. At the same time, raise the temperature of the liquid at the rate of 1 °C/min, the tolerance being such that the temperature rise during any 10 min interval is within 10 °C ± 2 °C.

If an elongated test piece retracts to its original length at –70 °C, cool to a lower temperature, using, if necessary, another heat-transfer medium.

Take the first reading when releasing the samples and continue to read the temperature and retracted length, or %, with a maximum interval of 2 min until a retraction of at least 71 %.