**Rubber — Determination of adhesion
to rigid materials using conical
shaped parts**

*Caoutchouc — Détermination de l'adhérence aux matériaux rigides
au moyen de pièces coniques*

iTeh STANDARD PREVIEW
(standards.iteh.ai)

[ISO 5600:2017](https://standards.iteh.ai/catalog/standards/sist/8759f44c-55d9-4650-a60a-51d922fdca36/iso-5600-2017)

<https://standards.iteh.ai/catalog/standards/sist/8759f44c-55d9-4650-a60a-51d922fdca36/iso-5600-2017>



iTeh STANDARD PREVIEW
(standards.iteh.ai)

ISO 5600:2017

<https://standards.iteh.ai/catalog/standards/sist/8759f44c-55d9-4650-a60a-51d922fdca36/iso-5600-2017>



COPYRIGHT PROTECTED DOCUMENT

© ISO 2017, Published in Switzerland

All rights reserved. Unless otherwise specified, no part of this publication may be reproduced or utilized otherwise in any form or by any means, electronic or mechanical, including photocopying, or posting on the internet or an intranet, without prior written permission. Permission can be requested from either ISO at the address below or ISO's member body in the country of the requester.

ISO copyright office
Ch. de Blandonnet 8 • CP 401
CH-1214 Vernier, Geneva, Switzerland
Tel. +41 22 749 01 11
Fax +41 22 749 09 47
copyright@iso.org
www.iso.org

Contents

	Page
Foreword	iv
1 Scope	1
2 Normative references	1
3 Terms and definitions	1
4 Principle	2
5 Apparatus	2
6 Calibration	2
7 Test piece	2
7.1 Form and dimensions	2
7.2 Materials	2
7.3 Preparation	3
7.4 Number of test pieces	3
7.5 Conditioning of test pieces	3
8 Procedure	4
9 Expression of results	4
9.1 Adhesion value	4
9.2 Type of adhesion failure	4
10 Salvaging of bonded metal parts	4
11 Test report	5
Annex A (normative) Calibration schedule	6

[ISO 5600:2017](https://standards.iteh.ai/catalog/standards/sist/8759f44c-55d9-4650-a60a-51d922fdca36/iso-5600-2017)

<https://standards.iteh.ai/catalog/standards/sist/8759f44c-55d9-4650-a60a-51d922fdca36/iso-5600-2017>

Foreword

ISO (the International Organization for Standardization) is a worldwide federation of national standards bodies (ISO member bodies). The work of preparing International Standards is normally carried out through ISO technical committees. Each member body interested in a subject for which a technical committee has been established has the right to be represented on that committee. International organizations, governmental and non-governmental, in liaison with ISO, also take part in the work. ISO collaborates closely with the International Electrotechnical Commission (IEC) on all matters of electrotechnical standardization.

The procedures used to develop this document and those intended for its further maintenance are described in the ISO/IEC Directives, Part 1. In particular the different approval criteria needed for the different types of ISO documents should be noted. This document was drafted in accordance with the editorial rules of the ISO/IEC Directives, Part 2 (see www.iso.org/directives).

Attention is drawn to the possibility that some of the elements of this document may be the subject of patent rights. ISO shall not be held responsible for identifying any or all such patent rights. Details of any patent rights identified during the development of the document will be in the Introduction and/or on the ISO list of patent declarations received (see www.iso.org/patents).

Any trade name used in this document is information given for the convenience of users and does not constitute an endorsement.

For an explanation on the voluntary nature of standards, the meaning of ISO specific terms and expressions related to conformity assessment, as well as information about ISO's adherence to the World Trade Organization (WTO) principles in the Technical Barriers to Trade (TBT) see the following URL: www.iso.org/iso/foreword.html (standards.iteh.ai)

This document was prepared by Technical Committee ISO/TC 45, *Rubber and rubber products*, Subcommittee SC 2, *Testing and analysis*.
ISO 5600:2017

[https://standards.iteh.ai/catalog/standards/sist/8759f44c-55d9-4650-a60a-](https://standards.iteh.ai/catalog/standards/sist/8759f44c-55d9-4650-a60a-5f89271ec211/iso-5600-2017)

This fifth edition cancels and replaces the fourth edition (ISO 5600:2011), of which it constitutes a minor revision to update the normative references in [Clause 2](#).

Rubber — Determination of adhesion to rigid materials using conical shaped parts

WARNING 1 — Persons using this document should be familiar with normal laboratory practice. This document does not purport to address all of the safety problems, if any, associated with its use. It is the responsibility of the user to establish appropriate safety and health practices and to ensure compliance with any national regulatory conditions.

WARNING 2 — Certain procedures specified in this document might involve the use or generation of substances, or the generation of waste, that could constitute a local environmental hazard. Reference should be made to appropriate documentation on safe handling and disposal after use.

1 Scope

This document specifies a method for the determination of the static vulcanized adhesion strength of rubber compounds to rigid materials. The test piece is composed of two conical ends of the rigid material, joined by a cylinder of rubber.

The adhesion is obtained by a bonding system which can include not only the rigid material and the rubber compound, but other elements such as thin alloy coatings or chemical treatments of rigid parts and either a single cement or both primer and cover cements. The bonding system for preparing the test pieces should be adequately specified by the user, but provision is made in this document for the evaluation of different types of failure related to a complex bonding system.

The method is designed primarily for test pieces prepared in the laboratory under standard conditions in order to provide data for development and control of bonding systems and their components, such as cements or special rubber compounds, and of methods of manufacture. While intended to be applied where the rubber is bonded to rigid supporting pieces, it might not cover such cases where the support, although of high-modulus material, has a low rigidity due to small transverse dimensions, as in the case of rubber bonded to metal wires, cords or thin sheets.

2 Normative references

The following documents are referred to in the text in such a way that some or all of their content constitutes requirements of this document. For dated references, only the edition cited applies. For undated references, the latest edition of the referenced document (including any amendments) applies.

ISO 5893:2002, *Rubber and plastics test equipment — Tensile, flexural and compression types (constant rate of traverse) — Specification*

ISO 18899:2013, *Rubber — Guide to the calibration of test equipment*

ISO 23529, *Rubber — General procedures for preparing and conditioning test pieces for physical test methods*

3 Terms and definitions

No terms and definitions are listed in this document.

ISO and IEC maintain terminological databases for use in standardization at the following addresses:

- IEC Electropedia: available at <http://www.electropedia.org/>
- ISO Online browsing platform: available at <http://www.iso.org/obp>

4 Principle

The test consists in measuring the force required to cause the rupture of a test piece of standard dimensions, comprising a cylinder of rubber bonded to two rigid conical parts.

The particular geometry of the test piece produces in most cases an interfacial failure between the cylinder of rubber and the conical parts because of a stress concentration at the tip of the cones.

5 Apparatus

5.1 Tensile-testing machine, complying with the requirements of ISO 5893:2002, class 2, and with a rate of traverse of the moving grip of (50 ± 5) mm/min.

Inertia (pendulum) type dynamometers have a tendency to give results which differ because of inertial effects. A low-inertia type dynamometer (for example, using an electronic or optical transducer) gives results which are free from this effect, and is therefore to be preferred.

5.2 Fixtures, for holding the test pieces in the test machine, which permit accurate centring of the applied load during the test.

6 Calibration

The test apparatus shall be calibrated in accordance with [Annex A](#).

7 Test piece

7.1 Form and dimensions

The standard test piece (see [Figure 1](#)) is formed by two rigid cylindrical parts terminated by opposite conical ends, and a cylinder of rubber bonded to the conical ends. The determination of the dimensions of the test piece shall be in accordance with ISO 23529.

The diameter of this cylinder and of the cylindrical portion of the rigid parts shall be $(25 \pm 0,5)$ mm. The distance between the tips of the conical ends shall be (12 ± 1) mm. The half-angle of the cone vertex shall be $45^\circ \pm 1^\circ$ and the tip shall be rounded to a radius not greater than 0,8 mm.

The cylindrical portion of each rigid part shall be not less than 5 mm in length and shall be terminated so as to match with the holding jaws ([5.2](#)) of the test machine ([5.1](#)).

7.2 Materials

The materials used shall conform to the specifications for the bonding system to be investigated. If no specification is given for the material of the rigid parts, they shall be made from low-carbon steel bars and their conical ends shall be grit-blasted.

Dimensions in millimetres

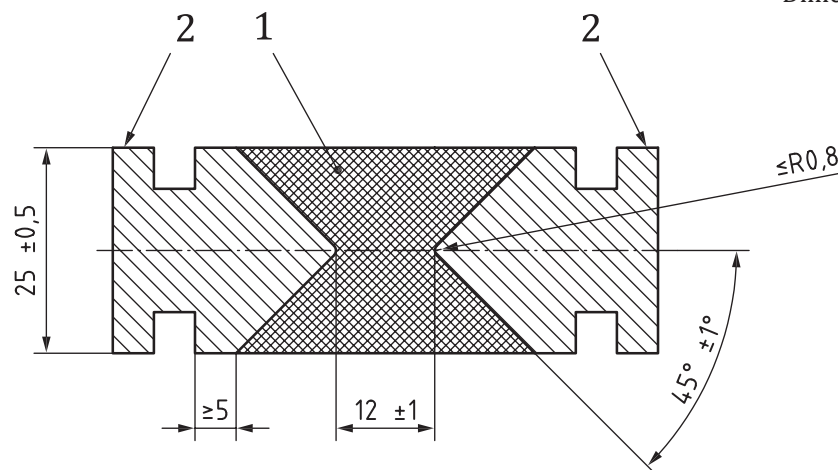
**Key**

- 1 rubber cylinder
- 2 rigid conical parts

Figure 1 — Standard test piece**7.3 Preparation**

7.3.1 Clean the surfaces of the conical ends or treat in accordance with the bonding system under investigation and, if so specified, coat with primer and/or cover cement. Spread the adhesive coating over the conical area only.

[ISO 5600:2017](https://standards.iteh.ai/catalog/standards/sist/8759f44c-55d9-4650-a60a-51d922f1ca36/iso-5600-2017)

[https://standards.iteh.ai/catalog/standards/sist/8759f44c-55d9-4650-a60a-](https://standards.iteh.ai/catalog/standards/sist/8759f44c-55d9-4650-a60a-51d922f1ca36/iso-5600-2017)

7.3.2 During the preparation of the test pieces, take great care when handling the materials to keep the bonding interfaces between the rubber and the rigid parts free from dust, moisture and foreign matter. Do not touch the treated conical surfaces with the hands during assembly.

7.3.3 Vulcanize the test pieces in a suitable transfer mould, properly insulated and provided with heaters and compression devices. Place the rigid parts and the rubber compound in the preheated mould for vulcanization. Use sufficient unvulcanized compound to fill the pot and provide some excess after filling the mould cavities.

The mould design should take account of the fact that machining the rigid parts for reuse will gradually reduce their size.

7.3.4 Carry out the vulcanization under the specified conditions of time, temperature and pressure.

7.3.5 At the conclusion of the cure, take great care when removing the test pieces from the mould to avoid subjecting the bonded surfaces to undue stress before the test pieces have cooled.

7.4 Number of test pieces

Prepare and test a minimum of three test pieces.

7.5 Conditioning of test pieces

Condition the test pieces in accordance with the requirements of ISO 23529 for at least 16 h at a standard laboratory temperature of $(23 \pm 2) ^\circ\text{C}$ or $(27 \pm 2) ^\circ\text{C}$. Use the same temperature throughout the test and throughout a series of tests intended to be comparable.

8 Procedure

8.1 Mount a test piece in the fixtures (5.2) of the tensile-testing machine (5.1). Take extreme care in centring and adjusting the test piece so that the tension is symmetrically distributed over the cross-section of the test piece during the test.

8.2 Apply the tension by separating the jaws at a constant rate of (50 ± 5) mm/min until the test piece breaks. Record the maximum force.

8.3 Recover the broken pieces and examine the failure surfaces.

8.4 Repeat for the remaining test pieces.

9 Expression of results

9.1 Adhesion value

Express the adhesion value, in newtons, required to produce failure. In cases where the failure is in the rubber bulk, the adhesion value is recognized as being higher than that recorded.

9.2 Type of adhesion failure

Express the type of adhesion failure, as determined by examination of the broken test pieces, by one or more of the following symbols:

R failure in the rubber bulk;

RC failure at the rubber/cover cement interface;

CP failure at the cover cement/primer cement interface;

M failure at the metal/primer cement interface.

Each symbol shall be followed by the percentage of the conical surface involved in that type of failure, estimated to the nearest 5 %.

NOTE The estimated percentage of the various types of failure can be expressed as in the following examples:

R 50, RC-50 means that roughly 50 % of the failure was in the rubber and the other 50 % at the rubber/cover cement interface.

R 25, RC-25, M-50 means three types of failure were present, with the M indicating that 50 % of the failure was at the metal/primer cement interface.

10 Salvaging of bonded metal parts

Bonded metal parts can be salvaged by the usual burning or chemical stripping techniques. Mechanical or chemical surface treatments can be used to re-establish a clean bonding surface.

The sharpness of the conical tip can be reduced during salvaging; this affects the reproducibility of the test results, and care shall be taken to re-establish the sharpness of the cone to a radius of 0,8 mm or less.

11 Test report

The test report shall include the following information:

- a) sample details:
 - 1) a description of the bonding system used, including materials, treatments and rubber cure (if the materials are of undisclosed composition, sufficient information shall be given to identify them),
 - 2) the date of vulcanization,
 - 3) the time and temperature of vulcanization;
- b) a reference to this document, i.e. ISO 5600;
- c) test details:
 - 1) the temperature of test,
 - 2) the type of dynamometer used,
 - 3) details of any operation not included in this document or in the International Standards to which reference is made, as well as any operation regarded as optional;
- d) test results:
 - 1) the adhesion values for each test piece, in newtons,
 - 2) a description of the types of failure for each test piece, expressed in accordance with 9.2,
 - 3) any unusual features noted during the determination;
- e) the date of the test.

<https://standards.iteh.ai/catalog/standards/sist/8759f44c-55d9-4650-a60a-51192361a266/iso-5600-2017>
 ISO 5600:2017

An example of a form for reporting adhesion test results is given in [Table 1](#).

Table 1 — Example of form for reporting adhesion test results

Test piece No.	Compound designation	Cure temperature °C	Cure time min	Substrate treatment	Date of		Adhesion value N	Type of break				Test temperature °C	Test equipment	Bonding system	Comments
					vulcanization	test		R	RC	CP	M				
								%	%	%	%				