



Designation: ~~D2229-04~~^{ε1} Designation: D2229 - 10

Standard Test Method for Adhesion Between Steel Tire Cords and Rubber¹

This standard is issued under the fixed designation D2229; the number immediately following the designation indicates the year of original adoption or, in the case of revision, the year of last revision. A number in parentheses indicates the year of last reapproval. A superscript epsilon (ϵ) indicates an editorial change since the last revision or reapproval.

~~^{ε1}Note—The reference to Table 2 was changed to Table 1 in Section 13.3 in March 2007.~~

1. Scope

- 1.1 This test method covers the determination of the force required to pull a steel cord from a block of vulcanized rubber.
- 1.2 Although designed primarily for steel cord, this test method may be applied with modifications to wire used in rubber products.
- 1.3 This test method can also be used for evaluating rubber compound performance with respect to adhesion to steel cord.
- 1.4 The values stated in SI units are to be regarded as the standard. No other units of measurement are included in this standard.
- 1.5 *This standard does not purport to address all of the safety concerns, if any, associated with its use. It is the responsibility of the user of this standard to establish appropriate safety and health practices and determine the applicability of regulatory limitations prior to use.*

2. Referenced Documents

2.1 ASTM Standards:²

- D76 Specification for Tensile Testing Machines for Textiles
- D123 Terminology Relating to Textiles
- D1566 Terminology Relating to Rubber
- D2904 Practice for Interlaboratory Testing of a Textile Test Method that Produces Normally Distributed Data
- D6477 Terminology Relating to Tire Cord, Bead Wire, Hose Reinforcing Wire, and Fabrics
- E105 Practice for Probability Sampling Of Materials
- E122 Practice for Calculating Sample Size to Estimate, With Specified Precision, the Average for a Characteristic of a Lot or Process

3. Terminology

3.1 Definitions

- 3.1.1 For definitions of terms relating to tire cord, bead wire, hose wire, and tire cord fabrics, refer to Terminology D6477.
 - 3.1.1.1 The following terms are relevant to this standard: adhesion, rubber compound, and steel cord.
 - 3.1.1.2 For definitions of terms relating to rubber, refer to Terminology D1566.
 - 3.1.1.3 For definitions of other terms related to textiles, refer to Terminology D123.

4. Summary of Test Method

- 4.1 The steel cords are vulcanized into a block of rubber and the force necessary to pull the cords linearly out of the rubber is measured.

5. Significance and Use

5.1 This test method is considered satisfactory for the acceptance testing of commercial shipments of steel tire cord because current estimates of between-laboratory precision for single materials are considered acceptable and the method has been used extensively in the trade for acceptance testing.

5.1.1 If there are differences or practical significances between reported test results for two laboratories (or more), comparative tests should be performed to determine if there is a statistical bias between them, using competent statistical assistance. As a

¹ This test method is under the jurisdiction of ASTM Committee D13 on Textiles and is the direct responsibility of Subcommittee D13.19 on Tire Cord and Fabrics. Current edition approved Oct. 1, 2004. Published October 2004. Originally published as D2229-63T. Last previous edition D2229-02. DOI: 10.1520/D2229-04E01. Current edition approved Jan. 1, 2010. Published January 2010. Originally approved in 1963. Last previous edition approved in 2004 as D2229-04 ^{ε1}. DOI: 10.1520/D2229-04E01.

² For referenced ASTM standards, visit the ASTM website, www.astm.org, or contact ASTM Customer Service at service@astm.org. For Annual Book of ASTM Standards volume information, refer to the standard's Document Summary page on the ASTM website.

TABLE 1 Critical Differences for Conditions Noted, 95 % Probability Level

Name of Property	Number of Observations	Single Operator Precision	Within-Laboratory Precision	Between-Laboratory Precision
Pull-out force, N		(Single-Material Comparisons)		
	4	49	52	85
	8	34	39	77
	16	24	31	74
		(Multi-Material Comparisons)		
	4	49	52	120
Rubber coverage, %	8	34	39	115
	16	24	31	112
		(Single-Material Comparisons)		
	4	7	7	19
	8	5	5	18
	16	4	4	18
	(Multi-Material Comparisons)			
4	11	11	28	
8	10	10	28	
16	9	9	28	

minimum, the test samples should be used that are as homogenous as possible, that are drawn from the material from which the disparate test results were obtained, and that are randomly assigned in equal numbers to each laboratory for testing. Other materials with established test values may be used for this purpose. The test results from the two laboratories should be compared using a statistical test for unpaired data, at a probability level chosen prior to the testing series. If a bias is found, either its cause must be found and corrected, or future test results must be adjusted in consideration of the known bias.

5.2 The mold described in this test method is primarily designed for quality acceptance testing for steel cord where the sample size for each cord is 4 or a multiple thereof, but any mold/cavity combination which will provide the required test block dimensions (Figs. 1 and 2) is acceptable.

5.3 Appendix X1 contains suggested ranges of environmental conditions for aging tests.

5.4 The property measured by this test method indicates whether the adhesion of the steel cord to the rubber is greater than the cohesion of the rubber, that is, complete rubber coverage of the steel cord, or less than the cohesion of the rubber, that is, lack of rubber coverage.

6. Apparatus

6.1 *Mold* (Figs. 2 and 3)—The mold is designed to produce four test blocks with the preferred dimensions, each containing 15 steel cords. The blocks are 200 mm long and 12.5 mm thick (embedded cord length). When testing cords equal to or less than

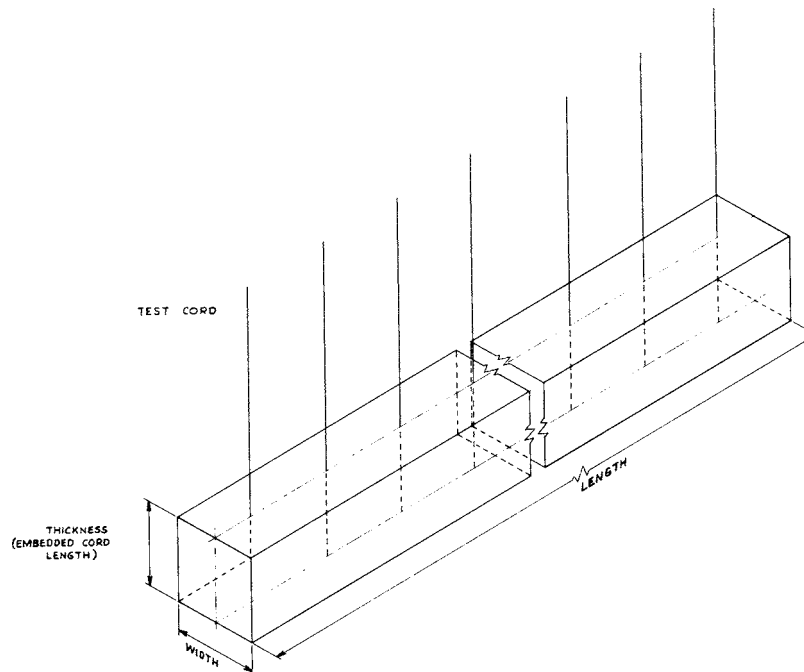
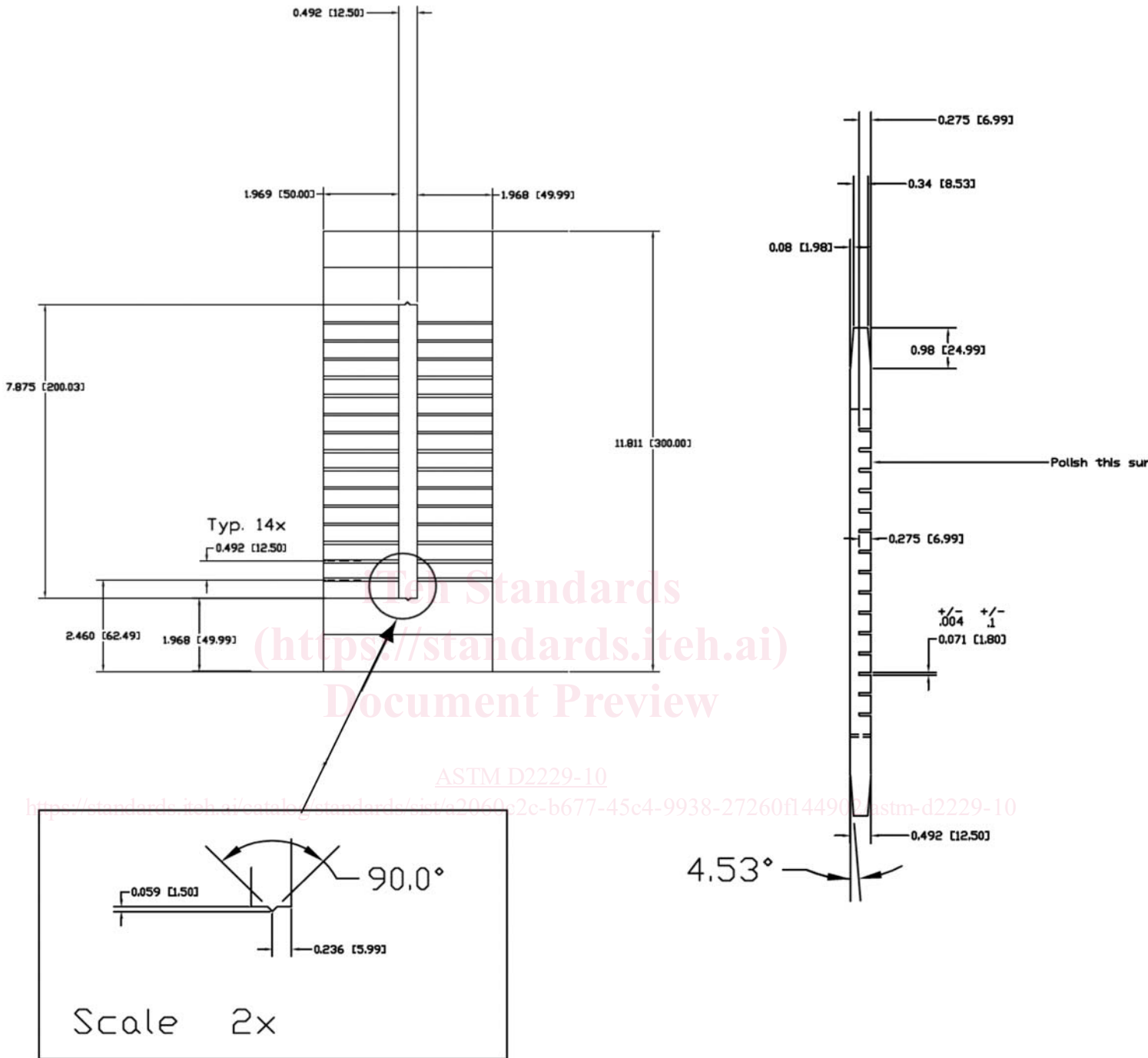

FIG. 1 Definition of Test Block Dimensions



TOLERANCES
 All dimensions ±0.2
 Angular ±2°
 Except where noted

NOTE 1—All dimensions in millimetres except where noted.

NOTE 2—Material—Mild steel.

NOTE 3—Mold should be coated permanently with a polytetrafluoro-ethylene, such as Teflon®, or preferably, with a stainless steel reinforced polytetrafluoro-ethylene with a polyamid binder, such as Excalibur®.

NOTE 4—Dimensions with “*” may be altered to accommodate test grips.

FIG. 2 Four-Cavity Steel Cord Adhesion Mold

1.7-mm diameter, the mold in Fig. 2 and Fig. 3 should be used to produce blocks, and when testing cords with a diameter greater than 1.7 mm, the mold should be suitably modified. Molds designed to produce any other number of test blocks of the required dimensions are acceptable, and molds designed to produce blocks with different embedded cord length are permitted.



TOLERANCES
 All dimensions ± 2
 Except where noted

ASTM D2229-10

- NOTE 1—Material—Mild steel.
 NOTE 2—Number required—2.
 NOTE 3—All dimensions in millimetres except where noted.
 NOTE 4—Dimensions with “*” may be altered to accommodate the mold.

FIG. 3 Top and Bottom Plates for Adhesion Mold

6.2 If more than one third of the cords break at the 12.5-mm embedment, it may be advisable to reduce the embedment by use of a suitable mold insert.

6.3 Testing Machine:

6.3.1 A constant-rate-of-extension (CRE) type tensile testing machine conforming to the requirements of Specification D76 for textiles shall be used for measuring the pull-out force. The rate of travel of the power actuated grip shall be 50 mm/min. Other rates of travel up to 150 mm/min may be used as agreed upon by the purchaser and the supplier.

6.3.2 The top grip shall apply force to the cord during testing that is normal to the face of the test block.

6.3.3 The bottom grip (Fig. 4) shall be a special holder made for the vulcanized test block.

6.4 *Press*—A curing press, large enough to take the mold, and capable of a minimum pressure of 3.5 MPa over the total area of the mold plate. Electrical or steam heat for the top and bottom platens shall be provided, of sufficient capacity for maintaining the mold components at the temperatures required for the rubber compound being used.

6.5 *Desiccator*.

7. Materials and Reagents

7.1 *Solvent*—A solvent may be used to freshen the surface of the rubber when necessary, provided such solvent treatment does not affect adhesion of the cord in the vulcanized block. A suitable solvent has been found to be a special lead-free gasoline (normal heptane), with a distillation range from 40 to 141°C and a maximum recovery of 97 %.

7.2 *Rubber Compound*—The rubber compound shall be furnished by the user of the cord, together with pertinent information of the temperature and time for the vulcanization of the particular rubber, as well as the conditioning period between vulcanization