



Designation: C1075 – 10

Standard Practices for Sampling Uranium-Ore Concentrate¹

This standard is issued under the fixed designation C1075; the number immediately following the designation indicates the year of original adoption or, in the case of revision, the year of last revision. A number in parentheses indicates the year of last reappraisal. A superscript epsilon (ϵ) indicates an editorial change since the last revision or reappraisal.

1. Scope

1.1 These practices are intended to provide the nuclear industry with procedures for obtaining representative bulk samples from uranium-ore concentrates (UOC) (see Specification C967).

1.2 These practices also provide for obtaining a series of representative secondary samples from the original bulk sample for the determination of moisture and other test purposes, and for the preparation of pulverized analytical samples (see Test Methods C1022).

1.3 These practices consist of a number of alternative procedures for sampling and sample preparation which have been shown to be satisfactory through long experience in the nuclear industry. These procedures are described in the following order.

Stage	Procedure	Section
Primary Sampling	One-stage falling stream	4
	Two-stage falling stream	5
	Auger	6
Secondary Sampling	Straight-path (reciprocating)	7
	Rotating (Vezin)	8, 9
Sample Preparation		10
	Concurrent-drying	11 – 13
	Natural moisture	14 – 16
	Calcination	17, 18
Sample Packaging		19
	Wax sealing	20
	Vacuum sealing	21

1.3.1 The primary and secondary sampling stages can be organized in the following way:

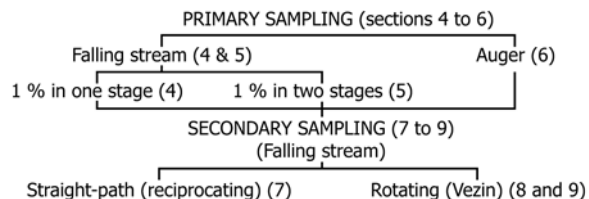

¹ These practices are under the jurisdiction of ASTM Committee C26 on Nuclear Fuel Cycle and are the direct responsibility of Subcommittee C26.02 on Fuel and Fertile Material Specifications.

Current edition approved Jan. 1, 2010. Published February 2010. Originally approved in 1986. Last previous edition approved in 2004 as C1075 – 93 (2004). DOI: 10.1520/C1075-10.

1.3.2 It is possible to combine the various elements of these stages in different ways to give satisfactory results depending on the agreed requirements of the contracting parties. For a given stage, however, each procedure must be regarded as a whole. It is highly inadvisable to mix elements belonging to different procedures.

1.4 These procedures do not include requirements for health, safety, and accountability. The observance of these practices does not relieve the user of the obligation to be aware of and to conform to all applicable international, federal, state, and local regulations pertaining to processing, shipping, or using uranium-ore concentrates. (Guidance is provided in CFR 10, Chapter 1.)

1.5 The values stated in SI units are to be regarded as the standard. The values given in parentheses are for information only.

1.6 *This standard does not purport to address all of the safety problems, if any, associated with its use. It is the responsibility of the user of this standard to establish appropriate safety and health practices and determine the applicability of regulatory limitations prior to use.*

2. Referenced Documents

- 2.1 *ASTM Standards*:²
[C967 Specification for Uranium Ore Concentrate](#)
[C1022 Test Methods for Chemical and Atomic Absorption Analysis of Uranium-Ore Concentrate](#)
- 2.2 *Other Document*:
[CFR 10 Nuclear Materials Licensing Code of Federal Regulations, Chapter 1](#)³

3. General Requirements

3.1 Material Requirements:

3.1.1 The uranium-ore concentrates shall be free-flowing and of a particle size not to exceed 6 mm (0.25 in.) or such other limit agreed upon between contracting parties.

² For referenced ASTM standards, visit the ASTM website, www.astm.org, or contact ASTM Customer Service at service@astm.org. For *Annual Book of ASTM Standards* volume information, refer to the standard's Document Summary page on the ASTM website.

³ Available from U.S. Government Printing Office Superintendent of Documents, 732 N. Capitol St., NW, Mail Stop: SDE, Washington, DC 20401, http://www.access.gpo.gov.

3.1.2 The average moisture content shall not exceed 5.0 % weight of the uranium-ore concentrates.

3.1.3 The material shall be shipped to the sampling plant in 200-L (55-gal) standard steel drums that are fitted with steel lids and equipped with suitable gasket, sealing rings, and sealing bungs (if applicable) to ensure weatherproofing. The drums shall be constructed so that the top of the drum is fully open when the lid is removed.

3.1.4 The number of drums in a sampling lot shall not exceed 90 and the gross weight shall not exceed 45 metric tons (100 000 lb).

3.1.5 A minimum number of drums in a sampling lot may be established depending upon the sampling procedure used.

3.2 Sampling Equipment Requirements:

3.2.1 Care shall be taken in the design and operation of the sampling and all associated equipment to minimize the exchanges of air between the atmosphere and the sampling system. For obvious safety reasons dust-carrying internal air must be prevented from escaping the system. This is achieved by means of dust collectors. The latter, however, shall be designed and operated in such a way that a minimum amount of external air shall be allowed into the system. The purpose of this is (1) to limit the exchanges of moisture between the atmosphere and the UOC and (2) to prevent a size-selective dusting. In any case, the amount of dust escaping the sampling operations must be kept to a minimum.

3.2.2 The scales for the gross and tare weights of the drums shall be capable of reading to the nearest 0.2 kg (0.5 lb) and shall be fitted with a print-out or data processing system, or both. They shall have a capacity of 600 kg (1300 lb). The

weigh scale shall be calibrated and adjusted if required, at the beginning, middle, and end of each lot weighed. Test weights shall be certified by a statutory authority and shall be traceable to national or state standards.

3.2.3 All sampling containers shall be clean and dry before usage.

4. Primary Sampling, Falling Stream—1 % In One Stage

4.1 Scope—The falling-stream procedure provides for removing a large number of increments of the material as it falls freely at a uniform, controlled rate. All of the material in a lot passes through the system and is subject to incremental sampling.

4.2 Sampling Equipment Requirements:

4.2.1 A schematic diagram of a typical falling-stream sampling facility is shown in Fig. 1. Subsequent procedures are described by reference to this equipment.

4.2.2 The flow of material through the falling-stream system shall be controlled by a rotary valve discharging to the hopper or pan of the first stage vibrating feeder. The rate of flow should not exceed $4.5 \times 10^{-2} \cdot \text{m}^3$ (1.6 ft³)/min and also should be controlled so that the cutter obtains from the falling stream at least 1 cut/ $2.8 \times 10^{-2} \cdot \text{m}^3$ (1.0 ft³) of material.

4.2.3 The first stage vibrating feeder should be adjusted so that the depth of the material in the trough (pan) does not exceed 50 mm (2.0 in.), and that the entire vertical cross section of the falling stream is totally intercepted by the cutter head.

4.2.4 The samplers should be designed and constructed as follows:

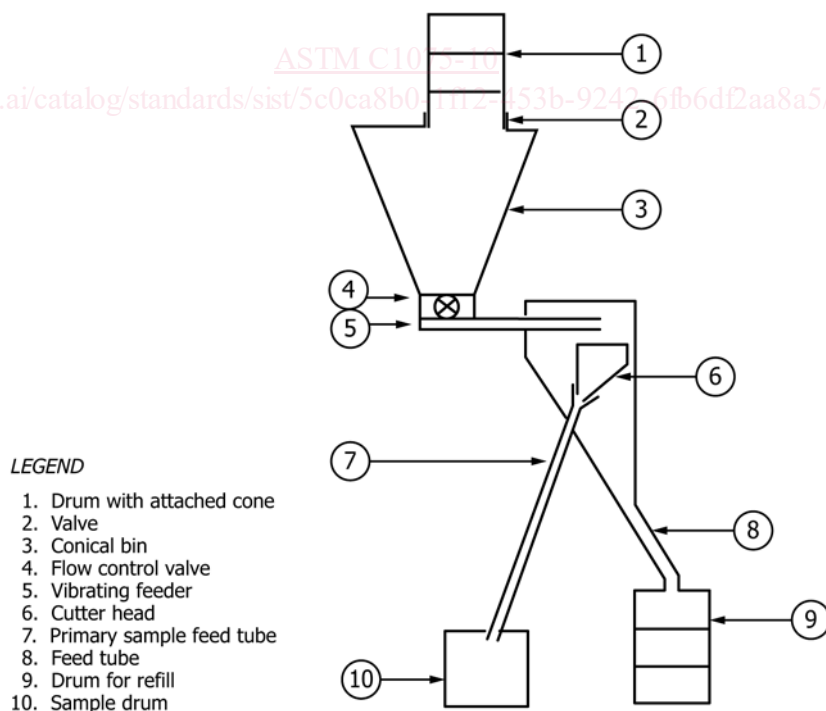

FIG. 1 Schematic Diagram of Falling-Stream Primary Sampler In One Stage

4.2.4.1 Approximately 1 % of the falling stream shall be diverted by the cutter. With small lots (for example, less than 10 tons), however, a larger percentage may be implemented in order to fulfill the requirements of the secondary sampling stage.

4.2.4.2 The horizontal linear speed of cutter heads shall not exceed 15 cm (6 in.)/s.

4.2.4.3 The width of the cutter head shall be no less than 30 mm (1.25 in.), that is, a minimum of five times the allowable particle size.

4.2.4.4 It is recommended that the cutter heads be constructed of stainless steel to improve their durability and reliability.

4.2.4.5 The top edges of the cutter heads shall be beveled to form knife edges.

4.3 Procedure for Obtaining the Primary Sample:

4.3.1 Clean and dry the tops of the drums if necessary, transfer them by means of a roller conveyor to the weigh scale, and record the gross weight to ±0.2 kg (±0.5 lb).

4.3.2 After the gross weights of the drums in a lot have been obtained, dump the contents of each drum into an elevated bin.

4.3.3 Equip the dumper with a vibrator and a dust collector designed and operated in accordance with 3.2.1.

4.3.4 After the drum is emptied, tare weigh the empty drum, lid, drum ring, and bolt.

4.3.5 Equip the bin into which the drums are dumped such as to facilitate the flow control and the transfer of material from the bin. The bin should have a conical bottom with a discharge opening or a size that will provide the desired flow.

4.3.6 The rotary valve discharge is received on an elongated vibrating feeder that stabilizes a consistent flow rate.

4.3.7 Remove a portion of the falling stream and receive it in a convenient surge bin mounted on a weighing system.

4.3.8 The contents of the surge bin are then fed to the secondary sampling system (see Sections 7 - 9).

4.3.9 Let the material not diverted by the cutter fall freely into a second bin from which the drums may be refilled if so desired.

5. Primary Sampling, Falling Stream—1 % In Two Stages

5.1 Scope—The falling-stream procedure provides for removing a large number of increments of the material as it falls freely at a uniform, controlled rate. All of the material in a lot passes through the system and is subject to incremental sampling.

5.2 Special Sampling Equipment Requirements:

5.2.1 A schematic diagram of a typical falling-stream sampling facility is shown in Fig. 2. Subsequent procedures are described by reference to this equipment.

5.2.2 The flow of material through the falling-stream system shall be controlled by a rotary valve discharging to the hopper or pan of the first stage vibrating feeder. The rate of flow should not exceed $4.5 \times 10^{-2} \cdot \text{m}^3$ (1.6 ft³)/min and also should be controlled so that the cutter obtains from the falling stream at least 10 cuts/ $2.8 \times 10^{-2} \cdot \text{m}^3$ (1.0 ft³) of material.

5.2.3 The first stage vibrating feeder should be adjusted so that the depth of the material in the trough (pan) does not exceed 50 mm (2.0 in.), and that the entire vertical cross section of the falling stream is totally intercepted by the cutter head.

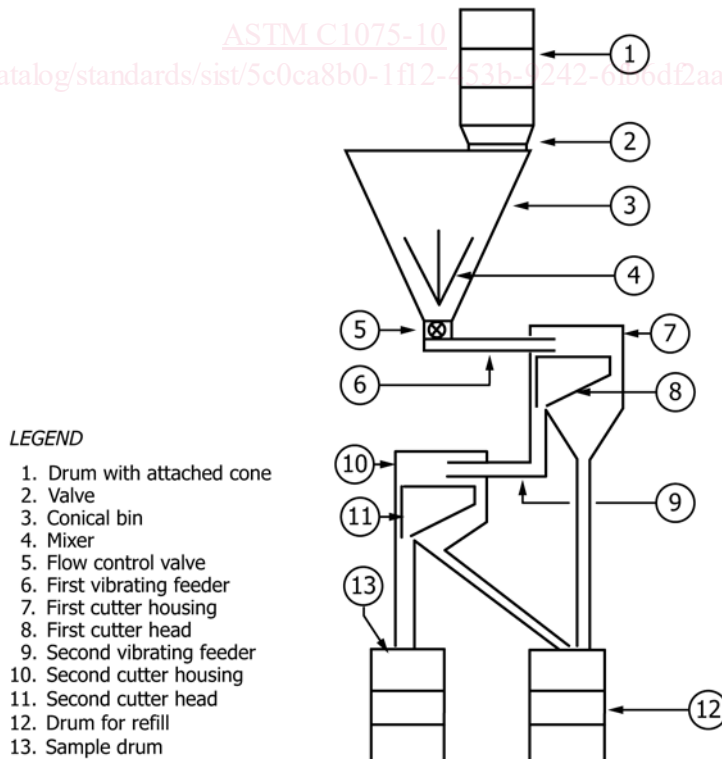

FIG. 2 Schematic Diagram of Falling Stream

5.2.4 The samplers should be designed and constructed as follows:

5.2.4.1 Approximately 10 % of each falling stream shall be diverted by each cutter.

5.2.4.2 The horizontal linear speed of cutter heads shall not exceed 15 cm (6 in.)/s.

5.2.4.3 The width of the cutter head shall be no less than 30 mm (1.25 in.), that is, a minimum of five times the allowable particle size.

5.2.5 It is recommended that the cutter heads be constructed of stainless steel to improve their durability and reliability.

5.2.6 The top edges of the cutter heads shall be beveled to form knife edges.

5.3 *Obtaining the Primary Sample Procedure:*

5.3.1 Clean and dry the tops of the drums if necessary, transfer them by means of a roller conveyor to the weigh scale, and record the gross weight to ± 0.2 kg (± 0.5 lb).

5.3.2 After the gross weights of the drums in a lot have been obtained, dump the contents of each drum into an elevated bin.

5.3.3 Equip the dumper with a vibrator and a dust collection designed and operated in accordance with the conditions of 3.2.1.

5.3.4 After the drum is emptied, tare weigh the empty drum, lid, drum ring, and bolt.

5.3.5 Equip the bin into which the drums are dumped such as to facilitate the flow control and the transfer of material from the bin. The bin should have a conical bottom with a discharge opening of a size that will provide the desired flow.

5.3.6 Set the rotary valve to deliver approximately 4.2 to 4.5×10^{-2} m³/min (1.5 to 1.6 ft³/min). This rate should not vary during the course of sampling of the entire lot.

5.3.7 Remove a portion of the falling stream and divert it to a second vibrating elongated feeder and cutter of similar design with a reciprocating cutter.

5.3.8 Direct the material diverted by the second stage cutter to a tared primary sample container, and close with a suitable lid depending on the secondary sampling procedure to be used (see Sections 7 – 9).

5.3.9 Let the material not diverted by the first- and second-stage cutters fall freely into a second bin from which the drums may be refilled if so desired.

5.3.10 Since approximately 10 % of each falling stream is diverted, the primary sample container will contain approximately 1 % of the entire lot. In no instance shall the total sample weight vary more than ± 5 % of the calculated value for the equipment employed.

6. Primary Sampling—Auger Sampling Procedure

6.1 *Scope*—The auger-sampling procedure provides for the removal of a core sample of the material from each drum by means of a tube that contains a rotating auger. Each drum of material passes through the system and is subject to individual sampling.

6.2 *Special Equipment Requirements:*

6.2.1 The auger sampler shall be designed and constructed so that approximately 0.5 % weight of the ore concentrate is withdrawn from each drum. Experience with a variety of uranium-ore concentrates show that a range from 0.3 to 0.7 %

can be expected. A schematic diagram of a typical auger-sampling facility is shown in Fig. 3. Subsequent procedures are described by reference to this equipment.

6.2.2 A tumbler shall be provided that is capable of rotating the sample drum about its axis at approximately 25 r/min. Before the tumbling operation, the sample drum shall be closed with either of the following:

6.2.2.1 A conical top fitted with a flow-control valve if the reciprocating cutter procedure is to be used for secondary sampling, or

6.2.2.2 A plain lid fixed by a metal band and bolt closure if the Vezin procedure is to be used for secondary sampling.

6.2.3 In order to achieve the operating limits required for the auger-sampling system the following design parameters are recommended:

6.2.3.1 The auger shall be constructed of suitable material (for example, tool or stainless steel) and shall have the following dimensions:

(1) *Auger Tube*—The outside diameter shall be 50 to 60 mm (1.968 to 2.375 in.) and the inside diameter shall be 43 mm (2.375 to 1.687 in.).

(2) *Length of Helix Within the Auger Tube*, shall be approximately 1400 mm (55 in.).

(3) *Pitch of Helix*, shall be approximately 25 mm (1 in.) apart.

(4) In operation, the end of the auger should protrude 6 to 25 mm (0.25 to 1.0 in.) below the auger tube.

6.2.3.2 The auger shall be made to have a minimum clearance allowing free rotation within the auger tube. The auger shall be capable of being rotated electrically and, when operating, shall turn at approximately 240 r/min.

6.2.4 The auger sampling system may be used as a single or double facility depending on design. In the latter case, two drums are sampled simultaneously with the two augers feeding a common hopper that discharges by means of a 75-mm (3-in.) flexible tube into a single sample drum of 200-L (55-gal) capacity.

6.3 *Obtaining the Primary Sample Procedure:*

6.3.1 Clean and dry the tops of the drums if necessary, transfer them by means of a roller conveyor to the weigh scale, and record the gross weight to ± 0.2 kg (± 0.5 lb). Pass the drums to the auger cabinet which shall be fitted with dust extraction and filtration equipment.

6.3.2 Remove the bolt and band from the drum, followed by the lid.

NOTE 1—It may be necessary to carry out preliminary operations outside the cabinet to free bolts, but removal of the lid shall only be done inside the cabinet.

6.3.2.1 Place the lid and band on a transporter running parallel to, and indexed to the drum or otherwise ensure that the lid and drum are matched so that the lid moves with and arrives together with the drum after sampling.

6.3.3 Position the drum so that the auger is at the center, midway to the perimeter, or near the perimeter above the surface of the ore concentrate. Adopt these sampling positions on successive drums in the sequence shown in Appendix X1 to take one sample from each drum.

LEGEND

1. Auger drive
2. Hollow auger tube
3. Sight glass
4. Powder valve
5. Auger helix
6. Drum to be sampled
7. Sample drum
8. Hydraulic lifting cradle

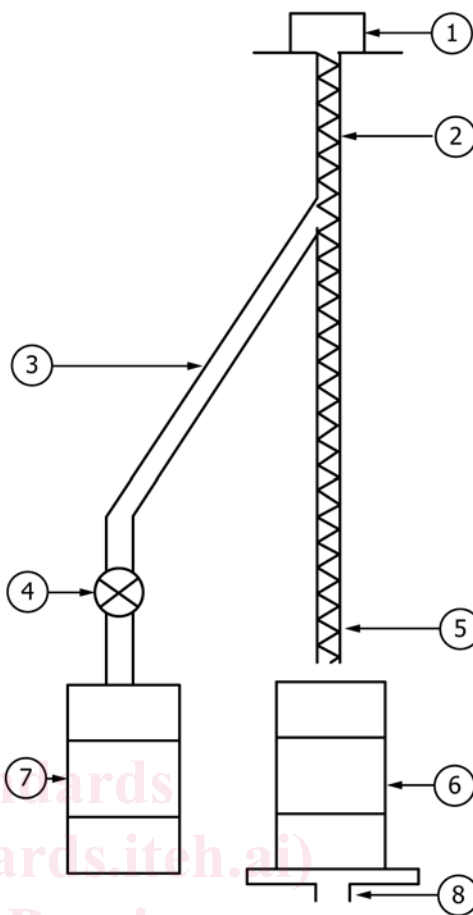

FIG. 3 Schematic Diagram of a Single Auger Primary Sampler

ASTM C1075-10

6.3.4 Raise the drum to be sampled on a mechanical or hydraulic ram to meet the enclosed auger which shall start to rotate as the surface of the powder meets the auger. Control the rise of the drum automatically so that cutoff occurs when the rotating base of the auger is within 12 to 25 mm (0.5 to 1.0 in.) of the bottom of the drum. Take the core samples of concentrate displaced vertically by subsequent samples and spill over the top of the auger tube to be collected in the prepared and tared sample drum. Combine the sample if two augers are used in parallel, and discharge into a common drum.

6.3.5 Sample a complete lot of concentrate then reverse the rotation of the auger, and displace the concentrate to be collected and add to the sample drum. Close the flow-control valve. Weigh the drum to confirm that the weight of the primary sample is 0.3 to 0.7 % weight of the lot sampled, and record the weight. If the weight is not within the 0.3 to 0.7 % weight range, check whether the auger-sampling system is operating effectively. If defective, correct the fault(s) and resample the lot.

6.3.6 Mix the primary sample by placing the sample drum on a tumbler and rotate at 25 r/min for 15 to 30 min, depending on the experience with particular ore concentrates. When the secondary sampler takes off directly from or immediately following the primary sample, this operation is not necessary.

7. Secondary Sampling—Straight-Path (Reciprocating) Cutter

7.1 *Equipment*—The basic components of this secondary sampler are the feeder, timer, counter, and sampling unit which contains at least six equally sized trays. The sampling units cut incremental samples of equal weights as the trays intercept the entire falling stream in succession. A schematic diagram of a reciprocating-cutter sample is shown in Fig. 4; the procedures in 7.2 are related to this equipment.

7.2 *Obtaining the Secondary Sample Procedure:*

7.2.1 This procedure is based on removing a series of samples of equal weight from a variable size primary sample by adjusting the timer controls on a reciprocating sample unit.

7.2.2 Attach the sample drum to the system by means of a conical top and a flow control valve.

7.2.3 Position the drum so that the valve discharges into a vibrating feeder that delivers the falling stream.

7.2.4 Adjust the feed rate to provide a steady flow of concentrate and to assure that a minimum of 100 cuts are taken of the falling stream.

7.2.5 Set the time system to assure that 1500 ± 200 -g samples per tray are obtained. Do not deviate the weights of the samples more than 30 g from the mean.

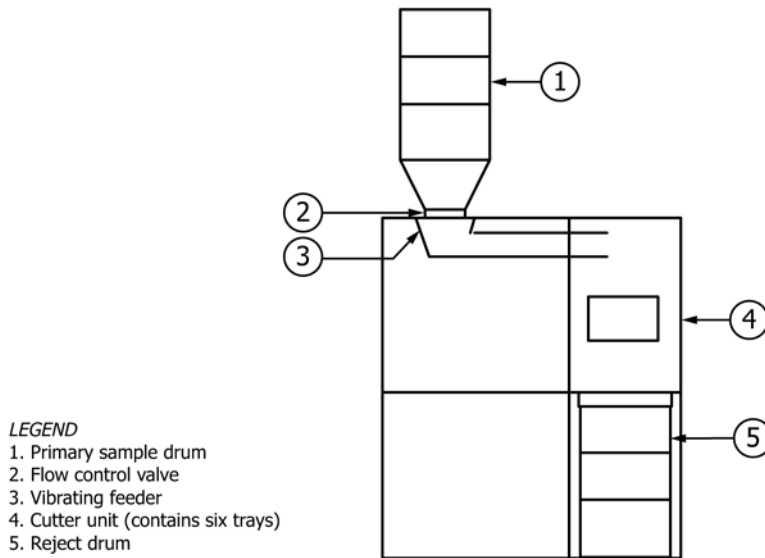

FIG. 4 Schematic Diagram of Reciprocating-Cutter Secondary Sampler

7.2.6 Collect the falling stream not caught by the cutter unit in a standard drum, then seal.

7.2.7 Transfer each of the six samples to sample jars of appropriate volume (about 2 L or 2 qt) and seal immediately.

7.2.7.1 Sample jars $n1$ to $n5$ will be used for analysis, while sample jar $n6$ is kept as a witness in case such a sample would be required in the future.

7.2.8 Number the samples consecutively from one side of the cutter unit to the other.

8. Secondary Sampling—Rotating (Vezin) Cutter

8.1 Equipment:

8.1.1 The basic components of this secondary sampler are a rotating drum cradle, a feed hopper, a vibrating feeder capable of feeding UOC at about 1 kg/min (2.2 lb/min), and the sampling unit that contains a constant speed rotating cup. A schematic diagram of a Vezin sampler is shown in Fig. 5; the procedures in 8.2 are related to this equipment.

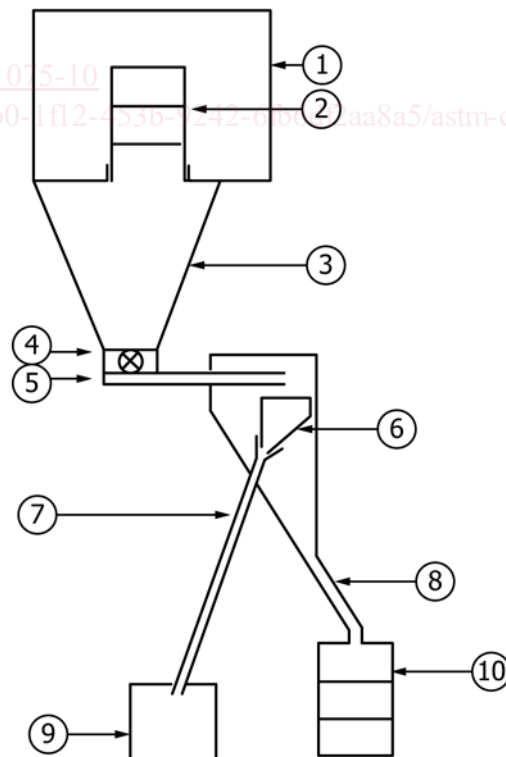

- LEGEND**
1. Drum tipping cabinet
 2. Primary sample drum
 3. Conical bin
 4. Powder valve
 5. Vibrating feeder
 6. Rotating Vezin sampler
 7. Secondary sample feed tube
 8. Reject sample feed tube
 9. Secondary sample collector
 10. Reject sample drum

FIG. 5 Schematic Diagram of Vezin Secondary Sampler