**Rubber and plastics hoses —
Assessment of ozone resistance under
dynamic conditions**

*Tuyaux en caoutchouc et en plastique — Évaluation de la résistance à
l'ozone dans des conditions dynamiques*

iTeh STANDARD PREVIEW
(standards.iteh.ai)

[ISO 10960:2017](https://standards.iteh.ai/catalog/standards/sist/bd692fd1-3c22-4d66-8891-19bc4cb8c630/iso-10960-2017)

<https://standards.iteh.ai/catalog/standards/sist/bd692fd1-3c22-4d66-8891-19bc4cb8c630/iso-10960-2017>



iTeh STANDARD PREVIEW
(standards.iteh.ai)

ISO 10960:2017

<https://standards.iteh.ai/catalog/standards/sist/bd692fd1-3c22-4d66-8891-19bc4cb8c630/iso-10960-2017>



COPYRIGHT PROTECTED DOCUMENT

© ISO 2017, Published in Switzerland

All rights reserved. Unless otherwise specified, no part of this publication may be reproduced or utilized otherwise in any form or by any means, electronic or mechanical, including photocopying, or posting on the internet or an intranet, without prior written permission. Permission can be requested from either ISO at the address below or ISO's member body in the country of the requester.

ISO copyright office
Ch. de Blandonnet 8 • CP 401
CH-1214 Vernier, Geneva, Switzerland
Tel. +41 22 749 01 11
Fax +41 22 749 09 47
copyright@iso.org
www.iso.org

Contents

	Page
Foreword	iv
1 Scope	1
2 Normative references	1
3 Terms and definitions	1
4 Principle	1
5 Apparatus	1
6 Test pieces	2
6.1 Type of test piece	2
6.2 Number of test pieces	2
7 Conditioning of test pieces	2
8 Test conditions	2
9 Procedure	2
10 Test report	3

iTeh STANDARD PREVIEW (standards.iteh.ai)

ISO 10960:2017

<https://standards.iteh.ai/catalog/standards/sist/bd692fd1-3c22-4d66-8891-19bc4cb8c630/iso-10960-2017>

Foreword

ISO (the International Organization for Standardization) is a worldwide federation of national standards bodies (ISO member bodies). The work of preparing International Standards is normally carried out through ISO technical committees. Each member body interested in a subject for which a technical committee has been established has the right to be represented on that committee. International organizations, governmental and non-governmental, in liaison with ISO, also take part in the work. ISO collaborates closely with the International Electrotechnical Commission (IEC) on all matters of electrotechnical standardization.

The procedures used to develop this document and those intended for its further maintenance are described in the ISO/IEC Directives, Part 1. In particular the different approval criteria needed for the different types of ISO documents should be noted. This document was drafted in accordance with the editorial rules of the ISO/IEC Directives, Part 2 (see www.iso.org/directives).

Attention is drawn to the possibility that some of the elements of this document may be the subject of patent rights. ISO shall not be held responsible for identifying any or all such patent rights. Details of any patent rights identified during the development of the document will be in the Introduction and/or on the ISO list of patent declarations received (see www.iso.org/patents).

Any trade name used in this document is information given for the convenience of users and does not constitute an endorsement.

For an explanation on the voluntary nature of standards, the meaning of ISO specific terms and expressions related to conformity assessment, as well as information about ISO's adherence to the World Trade Organization (WTO) principles in the Technical Barriers to Trade (TBT) see the following URL: www.iso.org/iso/foreword.html. (standards.iteh.ai)

This document was prepared by Technical Committee ISO/TC 45, *Rubber and rubber products*, Subcommittee SC 1, *Rubber and plastics hoses and hose assemblies*.

This second edition cancels and replaces the first edition (ISO 10960:1994), of which it constitutes a minor revision. The changes compared to the previous edition are as follows:

- [Clause 2](#) has been updated: ISO 471 has been deleted and replaced by ISO 23529, and the latest edition of ISO 1431-1 has been cited;
- [5.2](#) and [Clause 7](#) have been amended to cite the most recent pertinent standards.

Rubber and plastics hoses — Assessment of ozone resistance under dynamic conditions

1 Scope

This document specifies a method of assessing the resistance of hoses to the deleterious effects of atmospheric ozone under dynamic conditions. It is applicable to hoses with bore diameters up to and including 25 mm.

2 Normative references

The following documents are referred to in the text in such a way that some or all of their content constitutes requirements of this document. For dated references, only the edition cited applies. For undated references, the latest edition of the referenced document (including any amendments) applies.

ISO 1431-1:2012, *Rubber, vulcanized or thermoplastic — Resistance to ozone cracking — Part 1: Static and dynamic strain testing*

ISO 8330, *Rubber and plastics hoses and hose assemblies — Vocabulary*

ISO 23529, *Rubber — General procedures for preparing and conditioning test pieces for physical test methods*

3 Terms and definitions

For the purposes of this document, the terms and definitions given in ISO 8330 apply.

ISO and IEC maintain terminological databases for use in standardization at the following addresses:

- ISO Online browsing platform: available at <https://www.iso.org/obp>
- IEC Electropedia: available at <http://www.electropedia.org/>

4 Principle

The cover of a hose in a crescent position during reverse bending is exposed to ozone and examined periodically for cracking.

5 Apparatus

All apparatus placed in the test cabinet shall be made from materials which do not absorb or decompose ozone.

5.1 Ozone cabinet, with apparatus for generating ozone and monitoring and controlling the ozone concentration as described in ISO 1431-1.

5.2 Test piece holder, as shown in [Figure 1](#), with means of carrying out flexing at the required frequency.

Details given in ISO 1431-1:2012, 5.6, shall be followed.

6 Test pieces

6.1 Type of test piece

The test piece shall consist of a hose sample with a free length L calculated from the formula

$$L = 20 \times d$$

where d is the outside diameter of the hose under test.

6.2 Number of test pieces

Two test pieces shall be tested.

7 Conditioning of test pieces

No test shall be carried out within 24 h of manufacture. For evaluations which are intended to be comparable, the tests shall, as far as possible, be carried out after the same time interval after manufacture. ISO 23529 shall be followed for time between sample manufacture and testing.

The test pieces, mounted as described in 9.1, shall be conditioned for 48 h in a substantially ozone-free atmosphere at standard temperature in accordance with ISO 23529, in darkness or subdued light.

8 Test conditions

iTeh STANDARD PREVIEW
(standards.iteh.ai)

Unless other conditions are specified in the relevant hose specification, the test pieces shall be exposed in the ozone cabinet to an ozone concentration of (50 ± 5) parts per hundred million (pphm) by volume at $40 \text{ }^\circ\text{C} \pm 2 \text{ }^\circ\text{C}$ for (72 _{-2}^0) h.

NOTE It has been found that differences in atmospheric pressure can influence ozone cracking when test pieces are exposed to constant ozone concentrations expressed in parts per hundred million. This effect can be taken into account by expressing the ozone content in the ozonized air in terms of partial pressure, i.e. in millipascals, and making comparisons at constant ozone partial pressure. At standard conditions of atmospheric pressure and temperature (101 kPa, 273 K), a concentration of 1 pphm is equivalent to a partial pressure of 1,01 mPa.

9 Procedure

9.1 Mount the test piece as shown in [Figure 1](#) and place it in the ozone cabinet.

9.2 Carry out flexing at a frequency of $0,3 \text{ Hz} \pm 0,03 \text{ Hz}$ and in the test conditions as described in [Clause 8](#).

The maximum travel of the piston shall be such that the distance from the lower edge of the piston to the ends of the hose is five times the outside diameter of the hose $\pm 2 \text{ mm}$ (distance B in [Figure 1](#)). During the return stroke, the piston shall return to a position where the hose is completely unloaded.

9.3 Test pieces can be examined after periods of exposure of 2 h, 4 h, 24 h, 48 h and 72 h, while still mounted in the test apparatus, under $\times 2$ magnification, ignoring the area adjacent to the fixing point. If cracks are discovered, record their nature and the time at which they were first observed.

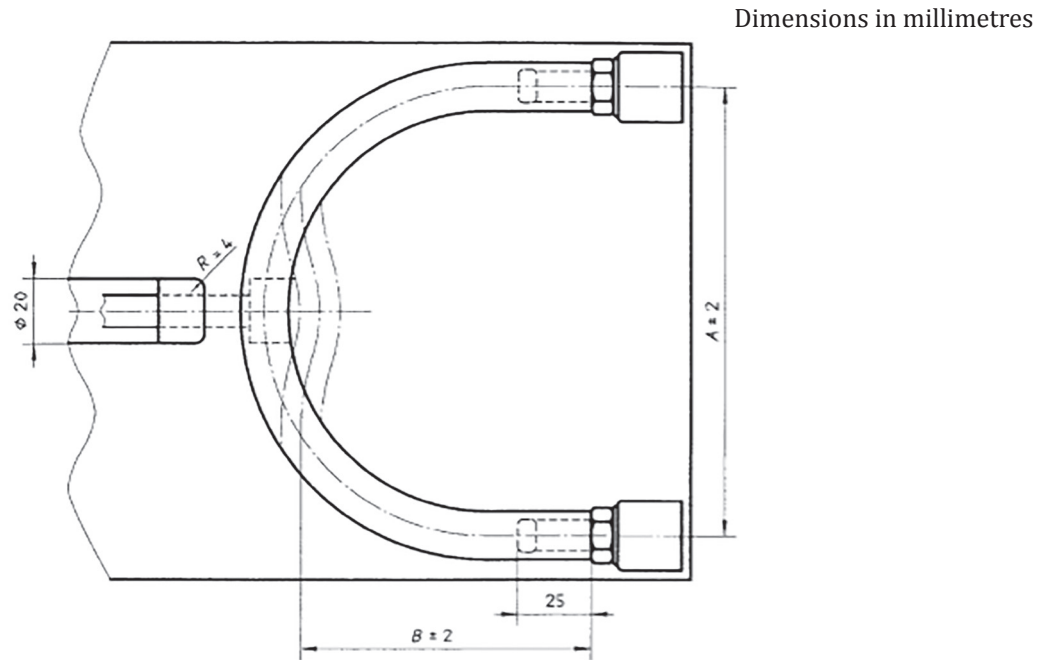
**Key**

A is $10d$

B is $5d$

R is radius of curvature of piston end

where d is the outside diameter of the hose under test.

ISO 10960:2017
<https://standards.iteh.ai/standards/iso-10960-2017/id66-8891-19bc4cb8c630/iso-10960-2017>
Figure 1 — Mounted test piece

10 Test report

The test report shall include the following information:

- a) a reference to this document, i.e. ISO 10960:2017;
- b) all details necessary for the identification of the hose tested;
- c) details of the test conditions, i.e. ozone concentration, temperature and exposure period;
- d) whether cracks were observed and, if so, their nature and the time the cracks were observed; and
- e) the date of the test.

iTeh STANDARD PREVIEW
(standards.iteh.ai)

[ISO 10960:2017](https://standards.iteh.ai/catalog/standards/sist/bd692fd1-3c22-4d66-8891-19bc4cb8c630/iso-10960-2017)

<https://standards.iteh.ai/catalog/standards/sist/bd692fd1-3c22-4d66-8891-19bc4cb8c630/iso-10960-2017>