



Designation: D2843-99 (Reapproved 2004)^{ε1} Designation: D2843 – 10

Standard Test Method for Density of Smoke from the Burning or Decomposition of Plastics¹

This standard is issued under the fixed designation D2843; the number immediately following the designation indicates the year of original adoption or, in the case of revision, the year of last revision. A number in parentheses indicates the year of last reapproval. A superscript epsilon (ϵ) indicates an editorial change since the last revision or reapproval.

This standard has been approved for use by agencies of the Department of Defense.

~~^{ε1}Note—Editorially changed Note 1 in December 2004.~~

1. Scope*

1.1 This fire-test-response test method covers a laboratory procedure for measuring and observing the relative amounts of smoke obscuration produced by the burning or decomposition of plastics. It is intended to be used for measuring the smoke-producing characteristics of plastics under controlled conditions of combustion or decomposition. Correlation with other fire conditions is not implied. The measurements are made in terms of the loss of light transmission through a collected volume of smoke produced under controlled, standardized conditions. The apparatus is constructed so that the flame and smoke ~~can be observed~~ is observable during the test.²

1.2 ~~Warning—~~During the course of combustion, gases or vapors, or both, are evolved that ~~may be~~ potentially hazardous to personnel. Adequate precautions ~~should~~ shall be taken to protect the operator.

1.3 The values stated in SI units are to be regarded as the standard. The values given in parentheses are for information purposes only.

1.4 ~~This standard should be used to measure and describe the response of materials, products, or assemblies to heat and flame under controlled laboratory conditions and should not be used to describe or appraise the fire hazard or fire risk of materials, products, or assemblies under actual fire conditions. However, results of this test may be used as elements of a fire hazard assessment or a fire risk assessment which takes into account all of the factors which are pertinent to an assessment of the fire hazard or fire risk of a particular end use.~~ This standard is used to measure and describe the response of materials, products, or assemblies to heat and flame under controlled conditions, but does not by itself incorporate all factors required for fire hazard or fire risk assessment of the materials, products, or assemblies under actual fire conditions.

1.5 ~~This standard does not purport to address all of the safety problems, if any, associated with its use. It is the responsibility of the user of this standard to establish appropriate safety and health practices and determine the applicability of regulatory limitations prior to use.~~ Specific warning statements are given in Fire testing is inherently hazardous. Adequate safeguards for personnel and property shall be employed in conducting these tests. Specific safety warning statements are given in 1.2 and 9.11-

² 1.6 ~~This standard does not purport to address all of the safety problems, if any, associated with its use. It is the responsibility of the user of this standard to establish appropriate safety and health practices and determine the applicability of regulatory limitations prior to use.~~

NOTE 1—There is no known ISO equivalent to this standard.

2. Referenced Documents

2.1 ASTM Standards:³

D618 Practice for Conditioning Plastics for Testing

D883 Terminology Relating to Plastics

D1600 Terminology for Abbreviated Terms Relating to Plastics

¹ This test method is under the jurisdiction of ASTM Committee D20 on Plastics and is the direct responsibility of Subcommittee D20.30 on Thermal Properties (Section D20.30.03).

Current edition approved Dec. Jan. 1, 2004-2010. Published January 2005-February 2010. Originally approved in 1970. Last previous edition approved in 2004 as D2843 - 99 (2004)^{ε1}. DOI: ~~10.1520/D2843-99R04E01~~ 10.1520/D2843-10.

² Anonymous, "A Method of Measuring Smoke Density," *NFPA Quarterly*, QNFPA, Vol 57, January 1964, p. 276. Reprint NFPA Q57-9. Available from NFPA, 60 Batterymarch St., Boston, MA 02110.

³ For referenced ASTM standards, visit the ASTM website, www.astm.org, or contact ASTM Customer Service at service@astm.org. For *Annual Book of ASTM Standards* volume information, refer to the standard's Document Summary page on the ASTM website.

*A Summary of Changes section appears at the end of this standard.

- E84 [Test Method for Surface Burning Characteristics of Building Materials](#)
 E176 [Terminology of Fire Standards](#)
 E662 [Test Method for Specific Optical Density of Smoke Generated by Solid Materials](#)
 E691 [Practice for Conducting an Interlaboratory Study to Determine the Precision of a Test Method](#)
 E906 [Test Method for Heat and Visible Smoke Release Rates for Materials and Products Using a Thermopile Method](#)
 E1354 [Test Method for Heat and Visible Smoke Release Rates for Materials and Products Using an Oxygen Consumption Calorimeter](#)

3. Terminology

3.1 *Definitions*—The terminology used in this test method is in accordance with Terminologies D883 and D1600 (terms relating to plastics) and Terminology E176 (terms relating to fire).

4. Summary of Test Method

4.1 The test specimen is exposed to flame for the duration of the test, and the smoke is substantially trapped in the chamber in which combustion occurs. A 25 by 25 by 6-mm (1 by 1 by ¼-in.) specimen is placed on supporting metal screen and burned in a laboratory test chamber (Fig. 1) under active flame conditions using a propane burner operating at a pressure of 276 kPa (40 psi). The 300 by 300 by 790-mm (12 by 12 by 31-in.) test chamber is instrumented with a light source, photoelectric cell, and meter to measure light absorption horizontally across the 300-mm (12-in.) light beam path. The chamber is closed during the 4-min test period except for the 25-mm (1-in.) high ventilation openings around the bottom.

4.2 The light-absorption data are plotted versus time. A typical plot is shown in Fig. 2. Two indexes are used to rate the material: the maximum smoke produced and the smoke-density rating.

5. Significance and Use

5.1 Tests made on a material under conditions herein prescribed can be of considerable value in comparing the relative smoke obscuration characteristics of plastics.

5.2 This test method serves to determine the extent to which plastic materials are likely to smoke under conditions of active burning and decomposition in the presence of flame.

NOTE 2—The visual and instrumental observations from this test compare well with the visual observations of the smoke generated by plastic materials when added to a freely burning large outdoor fire.⁴

5.3 The usefulness of this test procedure is in its ability to measure the amount of smoke obscuration produced in a simple, direct, and meaningful manner under the specified conditions. The degree of obscuration of vision by smoke generated by combustibles can be substantially known to be affected by changes in quantity and form of material, humidity, draft, temperature, and oxygen supply.

6. Apparatus

6.1 The smoke chamber shall be constructed essentially as shown in Fig. 1.⁵

6.1.1 Chamber:

6.1.1.1 The chamber shall consist of a 14-gage (B & S or AWG) 300 by 300 by 790-mm (12 by 12 by 31-in.) aluminum box to which is hinged a heat-resistant glass glazed door. This box shall be mounted on a 350 by 400 by 57-mm (14 by 16 by 2¼-in.) base which houses the controls. Dependent upon the materials tested, the metal may will require protection from corrosion.

6.1.1.2 The chamber shall be sealed except for 25 by 230-mm (1 by 9-in.) openings on the four sides of the bottom of the chamber. A 1700-L/min (60-ft³/min) blower shall be mounted on one side of the chamber. The inlet duct to the blower shall be equipped with a close-fitting damper. The outlet of the blower shall be connected through a duct to the laboratory exhaust system. If the chamber is in a ventilated hood, no connection to the lab exhaust system through a duct is needed.

6.1.1.3 The two sides adjacent to the door shall be fitted with 70-mm (2¾ in.) diameter smoke-tight glazed areas centered 480 mm (19¾ in.) above the base. At these locations and outside the chamber, boxes containing the optical equipment and additional controls shall be attached.

6.1.1.4 A removable white plastic plate shall be attached to the back of the chamber. There shall be a 90 by 150-mm (3½ by 6-in.) clear area centered about 480 mm above the bottom of the chamber through which is seen an illuminated white-on-red exit sign. The white background permits observation of the flame, smoke, and burning characteristics of the material. The viewing of the exit sign helps to correlate visibility and measured values.

6.1.2 Specimen Holder:

6.1.2.1 The specimen shall be supported on a 64-mm (2½-in.) square of 6 by 6-mm, 0.9-mm gage (¼ by ¼-in., 0.035-in. gage) stainless steel wire cloth 220 mm (8¾ in.) above the base and equidistant from all sides of the chamber. This screen shall lie in

⁴ Bartosic, A. J., and Rarig, F. J., "Evaluation of the XP2 Smoke Density Chamber," *Symposium on Fire Test Methods—Restraint & Smoke*, ASTM STP 422, ASTM, Philadelphia, PA, 1966.

⁵ Detailed drawings of the smoke chamber are also available at a nominal cost from ASTM Headquarters. Order Adjunct: ADJD2843.

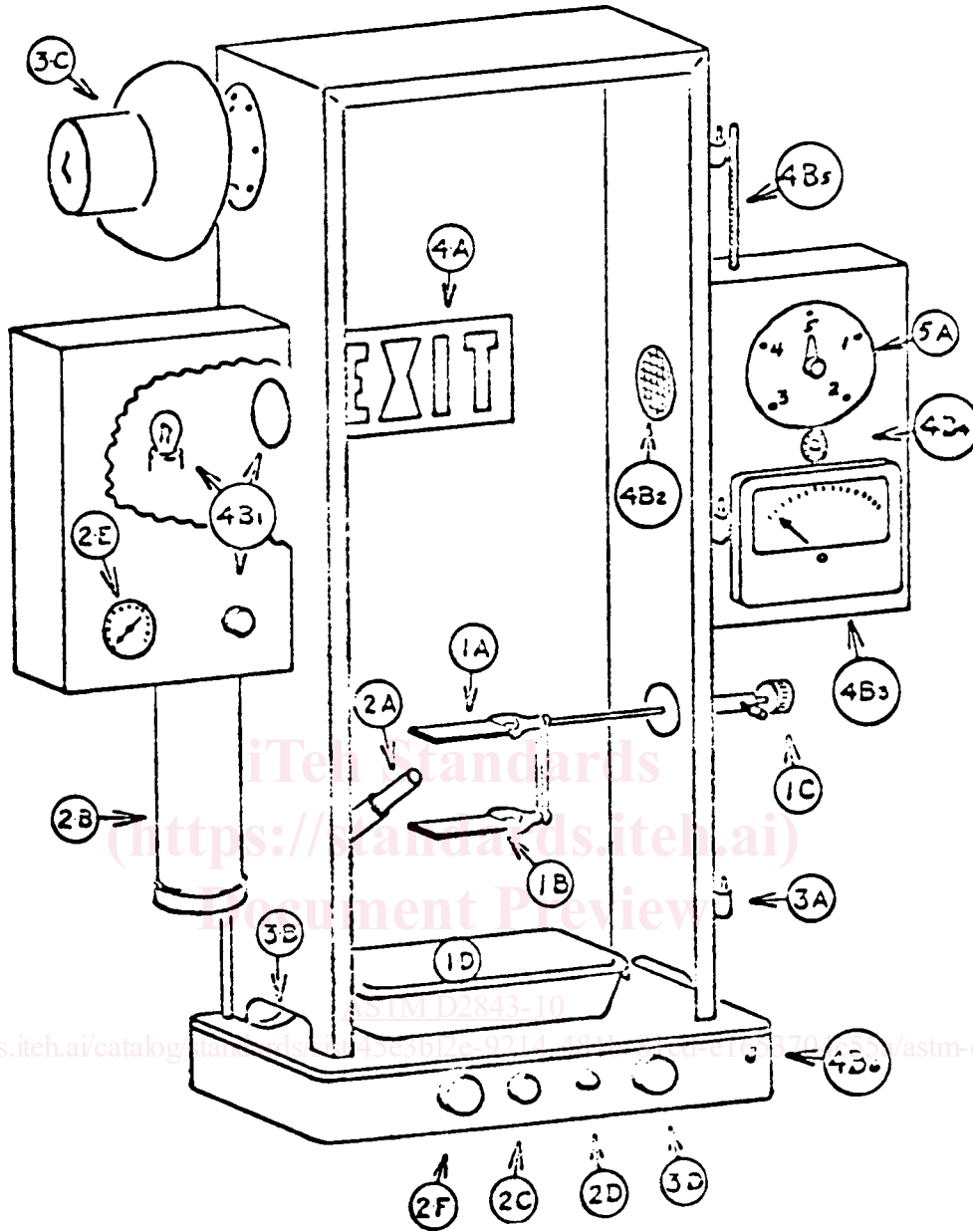

1. Specimen Holder
 - A Stainless steel screen
 - B Fire-Resistant Sheet
 - B Calcium-silicate sheet
 - C Adjusting knob
 - D Quench pan
2. Ignition
 - A Burner
 - B Propane tank
 - C Gas shut-off valve
 - D Pressure regulator adjustment
 - E Pressure indicator
 - F Burner-positioning knob
3. Cabinet (shown without door)
 - A Hinges (door gasketed three sides)
 - B Vents (25-mm (1-in.) high opening four sides)
 - C Blower (damper on mounting side)
 - D Control (blower on when damper is open)
4. Photometer
 - A Visual system (exit sign)
 - B Measuring system
 - 1 Light source and adjusting transformer
 - 2 Photronic cell and grid (to block stray light)
 - 3 Meter (indicating percent of light absorbed)
 - 4 Temperature compensation
 - 5 Photocell temperature monitor
 - 6 Range change
5. Timer
 - A Indicator, 0 to 5 min (friction reset)

FIG. 1 Schematic Diagram of Smoke Chamber

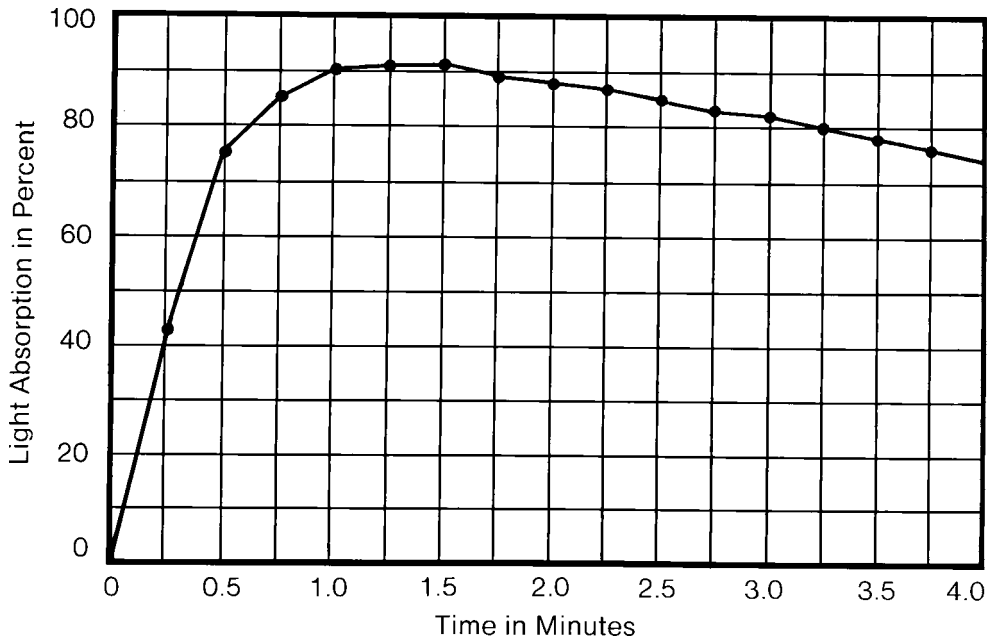

FIG. 2 Light Absorption versus Time

a stainless steel bezel supported by a rod through the right side of the chamber. From the same rod, a similar bezel shall be located 76 mm (3 in.) below, and it shall support a square of fire resistant material which catches any 1/4-in. thick calcium silicate to catch particles that may drip from the specimen during the test. ~~By rotating~~ At the conclusion of the test, rotate the specimen holder rod, rod and quench the burning specimen can be quenched in a shallow pan of water positioned below the specimen holder.

6.1.3 Ignition System:

6.1.3.1 The specimen shall be ignited by a propane flame from a burner operating at a pressure of 276 kPa (40 psi). The fuel (Note 3) shall be mixed with air which that has been propelled through the burner by the venturi effect of the propane as it passes from a 0.13-mm (0.005-in.) diameter orifice (Note 4), and the burner shall be assembled as shown in the exploded view of the burner in Fig. 3. The burner must be designed to provide adequate outside air.

NOTE 3—Commercial grade 85.0 % minimum, gross heating value 23 000 cal/litre (2590 Btu/ft³) propane meets the requirements.

NOTE 4—Since the orifice provides the metering effect proportionate to the supply pressure, care must be taken that the orifice is the only means of fuel egress.

6.1.3.2 The burner shall be capable of being positioned quickly under the specimen so that the axis of the burner falls on a line passing through a point 8 mm (3/10 in.) above the base at one back corner of the chamber extending diagonally across the chamber and sloping upward at 45 deg with the base. The exit opening of the burner shall be 260 mm (10 1/4 in.) from the reference point at the rear of the chamber.

6.1.3.3 A duct at least having a minimum diameter of 150 mm (6 in.) outside of the chamber shall provide the air piped to the burner.

6.1.3.4 Propane pressure shall be adjustable and preferably automatically regulated. Propane pressure shall be indicated by means of a Bourdon tube gage.

6.1.4 Photometric System:

6.1.4.1 A light source, a barrier-layer photoelectric cell, and a temperature compensated meter shall be used to measure the proportion of a light beam which penetrates a 300-mm (12-in.) path through the smoke. The light path shall be arranged horizontally as shown in Fig. 4.

6.1.4.2 The light source shall be mounted in a box (4B1 in Fig. 1) extending from the left side of the chamber at the mean height of 480 mm (19 3/4 in.) above the base. The light source shall be a compact filament microscope lamp No. 1493 operated at 5.8 V and a spherical reflector, with power supplied by a voltage-regulating transformer. A 60 to 65-mm (2 1/2-in.) focal length lens shall focus a spot of light on the photocell in the right instrument panel.

6.1.4.3 Another box containing the photometer (4 B2 in Fig. 1) shall be attached to the right side of the chamber. The barrier-layer photoelectric cell shall have standard observer spectral response. An egg-crate grid in front of the photocell shall be used to protect the cell from stray light. The grid shall be finished in dull black and have openings at least twice as deep as they are wide. The current produced by the photocell is indicated in terms of percent light absorption on a meter. The photocell linearity decreases as the temperature increases; compensations shall therefore be made.

NOTE 5—Photocell manufacturers recommend operating the photocell at temperatures not exceeding 50°C. 5—Do not operate the photocell at temperatures exceeding 50°C.

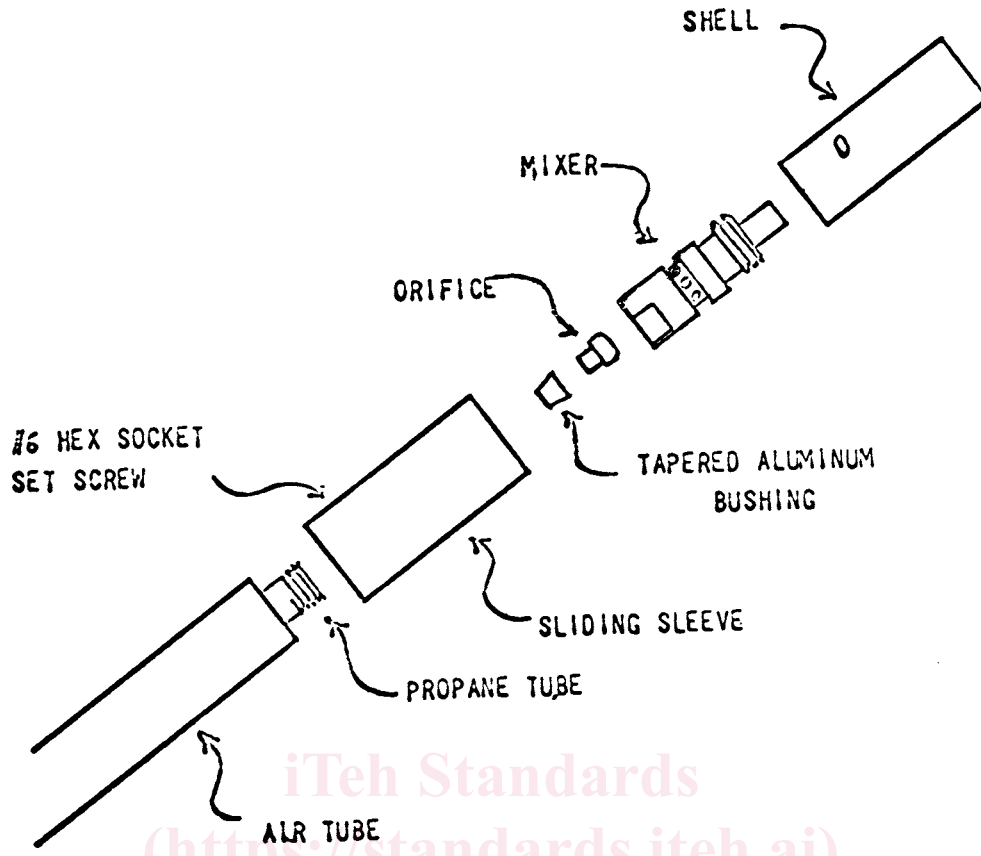
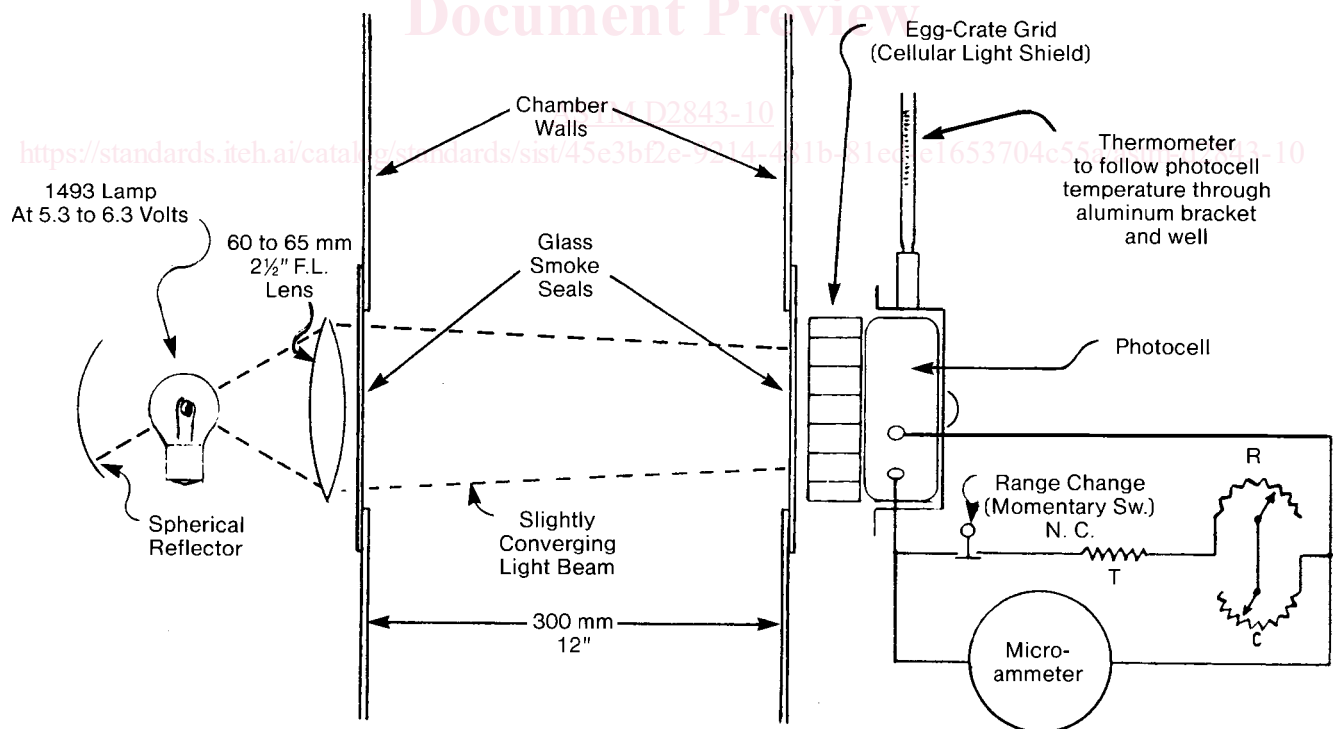

FIG. 3 Exploded View of Burner



T = Temperature-sensitive winding in or on meter case to increase in resistance in proportion to increase in meter resistance with temperature.
 R = Potentiometer with calibrated scale to reduce resistance in proportion to decrease in photocell output with rise in temperature.
 C = Potentiometer to calibrate total resistance of shunt to change meter sensitivity exactly by 10:1 ratio.

FIG. 4 Smoke Density Test Chamber Photometer

6.1.4.4 The meter shall have two ranges. The range change shall be accomplished by shunting the meter to one tenth of its sensitivity. When smoke accumulates to absorb 90 percent of the light beam, a momentary switch shall be depressed returning the meter to its basic sensitivity. By doing this the meter scale will then read from 90 to 100 % instead of 0 to 100 %.

6.1.5 *Timing Device*—A clock to indicate 15-s intervals shall be used. If the time intervals are audibly marked it will be convenient for the operator to record his observations. A clutch shall be used to reset the clock at the start of a test. The block shall be coupled to the burner-positioning device and it shall start when the burner is swung into test position.

6.1.6 *Planimeter*—A planimeter or other suitable means shall be used for measuring the area under the light-absorption curve.

7. Test Specimen

7.1 The standard specimen shall be 25.4 ± 0.3 by 25.4 ± 0.3 by 6.2 ± 0.3 mm (1 ± 0.01 by 1 ± 0.01 by $\frac{1}{4} \pm 0.01$ in.). ~~Thicknesses other than 6.2 mm ($\frac{1}{4}$ in.) may be used and their size must be reported with the smoke density values (Note 6). Material thinner than 6.2 mm ($\frac{1}{4}$ in.) may be tested, either in its normal use thickness, or by stacking and forming a composite specimen approximately 6.2 mm ($\frac{1}{4}$ in.) thick. Material thicker than 6.2 mm ($\frac{1}{4}$ in.) may be tested either in its normal use thickness or by machining the material down to a thickness of 6.2 mm ($\frac{1}{4}$ in.).~~

~~NOTE 6—If specimens other than the standard specimen are to be used, cooperating laboratories should agree upon preparation procedures and dimensions of the specimen. The results in such cases may vary from the results obtained with the standard specimen. ± 0.01 in.). Material thinner than 6.2 ± 0.3 mm shall be tested by stacking and forming a composite specimen 6.2 ± 0.3 mm thick. Material thicker than 6.2 mm ($\frac{1}{4}$ in.) shall be tested by machining the material down to a thickness of 6.2 ± 0.3 mm.~~

7.2 The specimens shall be sanded, machined, or die cut in a manner that produces a cut surface that is free from projecting fibers, chips, and ridges.

7.3 The test sample shall consist of three specimens.

8. Conditioning

8.1 *Conditioning*—Condition the test specimens at $23 \pm 2^\circ\text{C}$ ($73.4 \pm 3.6^\circ\text{F}$) and $50 \pm 5\%$ relative humidity for not less than 40 h prior to test in accordance with Procedure A of Practice D618, for those tests where conditioning is required. In cases of disagreement, the tolerances shall be $\pm 1^\circ\text{C}$ ($\pm 1.8^\circ\text{F}$) and $\pm 2\%$ relative humidity.

8.2 *Test Conditions*—Conduct tests in the standard laboratory atmosphere of $23 \pm 2^\circ\text{C}$ ($73.4 \pm 3.6^\circ\text{F}$) and $50 \pm 5\%$ relative humidity, unless otherwise specified in the test methods or in this test method. In cases of disagreement, the tolerances shall be 1°C ($\pm 1.8^\circ\text{F}$) and $\pm 2\%$ relative humidity.

8.3 Tests shall be conducted in a hood that has a window for observing the test.

9. Standard Procedure

9.1 Turn on the photometer lamp, exit sign, and exhaust blower.

9.2 Turn on the propane, ignite the burner, and adjust the propane pressure to 276 kPa (40 psi). **Warning**—Do not fail to light the burner immediately.

9.2 Turn on the propane, immediately ignite the burner, and adjust the propane pressure to 276 kPa (40 psi).

9.3 Set the temperature compensation.

9.4 Adjust the lamp control to zero percent light absorption.

9.5 Lay the test specimen flat on the screen in such a position that the burner flame will be directly under the specimen when the burner is swung into position.

9.6 Set the timer to zero.

9.7 Shut off the exhaust blower, close the smoke chamber door, and immediately position the burner under the specimen and start the timer.

9.8 If in a hood, shut off the hood fan and close the hood door to within 50 mm (2 in.) of the bottom of the hood.

9.9 Record the percent light absorbed at 15-s intervals for 4 min.

9.10 Record observations during the conduct of the test. Include the time it takes for the sample to burst into flame, the time for flame extinguishment or specimen consumption, the obscuration of the exit sign by smoke accumulation, and any general or unusual burning characteristics noted such as melting, dripping, foaming, or charring.

9.11 Upon completion of the test, turn on the exhaust blower to ventilate the combustion products from the chamber. **(Warning—It should be noted that for some materials the**

~~NOTE 6—All products of burning may be toxic, and care should combustion are toxic. Care shall be taken to guard the operator from the effects of these gases. The ventilating fan in the hood should must be turned on and the damper opened immediately after the test is completed before opening the hood door in order to remove any irritating or toxic products of the test. The exhaust fan is turned off and the hood damper closed during the test to prevent back draft.)draft.~~

9.12 Open the door and clean the combustion deposits from the photometer, exit sign, and door glass with detergent and water. Burn off any material remaining on the screen or replace the screen and asbestos-square of $\frac{1}{4}$ -in. thick calcium silicate for the next test.

9.13 Run all tests in triplicate.