



Designation: F903–03 (Reapproved 2004) Designation: F903 – 10

# Standard Test Method for Resistance of Materials Used in Protective Clothing to Penetration by Liquids<sup>1</sup>

This standard is issued under the fixed designation F903; the number immediately following the designation indicates the year of original adoption or, in the case of revision, the year of last revision. A number in parentheses indicates the year of last reapproval. A superscript epsilon ( $\epsilon$ ) indicates an editorial change since the last revision or reapproval.

## INTRODUCTION

Workers involved in the production, use, and transportation of liquid chemicals can be exposed to numerous compounds capable of causing harm upon contact with the human body. The deleterious effects of these chemicals can range from acute trauma such as skin irritation and burn to chronic degenerative disease, such as cancer. Since engineering controls may not eliminate all possible exposures, attention is often placed on reducing the potential for direct skin contact through the use of protective clothing that resists permeation, penetration, and degradation.

This test method determines resistance to penetration only. Resistance to permeation and degradation should be determined by other test methods.

## 1. Scope

1.1 This test method is used to test specimens of protective clothing and candidate materials and constructions to be used in protective clothing. The resistance to visible penetration of the test liquid is determined with the liquid in continuous contact with the normally outside surface of the test specimen.

1.2 In some cases, significant amounts of hazardous materials will permeate specimens that pass the penetration tests. For more sensitive analysis use Test Method F739 to determine permeation.

1.3 This test method is not applicable to finger tips or crotch areas of gloves, which are possible failure points.

1.4 The values as stated in inch-pound units are to be regarded as the standard. The values in ~~brackets~~parentheses are for information only.

1.5 *This standard does not purport to address all of the safety concerns, if any, associated with its use. It is the responsibility of the user of this standard to establish appropriate safety and health practices and determine the applicability of regulatory limitations prior to use.* Specific hazards are given in Section 7.

## 2. Referenced Documents

2.1 *ASTM Standards:*<sup>2</sup>

D1777 Test Method for Thickness of Textile Materials

E105 Practice for Probability Sampling Of Materials

F104 Classification System for Nonmetallic Gasket Materials

F739 Test Method for Permeation of Liquids and Gases through Protective Clothing Materials under Conditions of Continuous Contact

## 3. Terminology

3.1 *Definitions:*

3.1.1 *degradation, n*—a deleterious change in one or more properties of a material.

3.1.2 *penetration, n*—~~the movement of matter through closures, porous materials, seams, and pinholes or other imperfections in protective clothing on a nonmolecular level.~~ for chemical protective clothing, the movement of substances through voids in

<sup>1</sup> This test method is under the jurisdiction of ASTM Committee F23 on Personal Protective Clothing and Equipment and is the direct responsibility of Subcommittee F23.30 on Chemical Resistance.

Current edition approved June 1, 2004. Published July 2004. Originally approved in 1984. Last previous edition approved in 2003 as F903-03. DOI: 10.1520/F0903-03R04 on Chemicals.

Current edition approved Jan. 1, 2010. Published February 2010. Originally approved in 1984. Last previous edition approved in 2004 as F903 - 03(2004). DOI: 10.1520/F0903-10.

<sup>2</sup> For referenced ASTM standards, visit the ASTM website, [www.astm.org](http://www.astm.org), or contact ASTM Customer Service at [service@astm.org](mailto:service@astm.org). For *Annual Book of ASTM Standards* volume information, refer to the standard's Document Summary page on the ASTM website.

aprotective clothing material or item on a non-molecular level.

3.1.2.1 *Discussion*—For this test method, the specific matter is a liquid chemical. —Voids include gaps, pores, holes, and imperfections in closures, seams, interfaces, and protective clothing materials. Penetration does not require a change of state; solid chemicals move through voids in the material as solids, liquids as liquids, and gases as gases. Penetration is a distinctly different mechanism from permeation.

3.1.3 *permeation, n*—the process by which a chemical moves through a protective clothing material on a molecular level. —for chemical protective clothing, the movement of chemicals as molecules through protective clothing material items by the processes of (1) absorption of the chemical into the contact surface of the material, (2) diffusion of the absorbed molecules throughout the material, and (3) desorption of the chemical from the opposite surface of the material.

3.1.3.1 *Discussion*—Permeation involves the following: (1) absorption of molecules of the chemical into the contacted (challenge side) surface of the material, (2) diffusion of the sorbed molecules in the material, and (3) desorption of the molecules from the opposite (collection side) surface of the material. —Permeation is a distinctly different mechanism from penetration.

3.1.4 *protective clothing, n*—a garment used for the purpose of isolating parts of the body from contact with a potential hazard. —an item of clothing that is specifically designed and constructed for the intended purpose of isolating all or part of the body from a potential hazard; or, isolating the external environment from contamination by the wearer of the clothing.

3.1.4.1 *Discussion*—The potential hazard addressed by this test method is penetration by liquids.

## 4. Summary of Test Method

4.1 A specimen is subjected to a liquid for a specified time and pressure sequence and observed for visible penetration of the liquid. If the liquid passes through the specimen, the material fails the test for resistance to penetration of the liquid.

4.2 In the penetration test apparatus, the specimen acts as a partition separating the hazardous liquid chemical from the viewing side of the test cell.

## 5. Significance and Use

5.1 This test method is normally used to evaluate the barrier effectiveness against liquids of materials used for protective clothing and specimens from finished items of protective clothing.

5.1.1 Finished items of protective clothing include gloves, arm shields, aprons, suits, hoods, boots, and the like.

5.1.2 The phrase “specimens from finished items” encompasses seamed and other discontinuous regions as well as the usual continuous regions of protective clothing items.

5.2 A substitute challenge liquid (for example, water) is appropriate in some cases. However, it is possible that differences in chemical and molecular properties (for example, surface tension) lead to different results.

## 6. Apparatus

6.1 *Thickness Gage*, suitable for measuring thickness to the nearest 0.001 in. or ~~nearest~~(nearest 0.01 mm),mm), as specified in Test Method D1777.

6.2 *Liquid Penetration Tester*, as shown in Figs. 1-8 . See Table 1 for parts and materials.

6.2.1 *Test Cell*, consisting of a chamber for the challenge liquid and a restraining ring which holds the outside surface of the specimen in contact with the challenge liquid on the open side of the chamber and which allows observation of the specimen’s inside surface through a viewing port. A transparent cover is optional.

6.2.2 *Safety Shield*, transparent and shatter (proof)/resistant, to separate the liquid penetration tester from the observer (see Fig. 1).

6.2.3 *Screen*, retaining, optional (see Table 2), with at least 50 % open area. The purpose of the screen is to limit distention of the test specimen to 0.2 in. ~~{5 mm}~~(5 mm) or less. Examples of retaining screens are 11 by 11 nylon screen, 14 by 14 polypropylene screen, and 13 by 13 polyester screen.<sup>3</sup>

## 7. Hazards

7.1 Before carrying out this test method, identify and review safety precautions recommended for handling each hazardous chemical of interest to provide full protection to all personnel.

7.1.1 For carcinogenic, mutagenic, teratogenic, and other toxic (poisonous) chemicals, isolate the work area under adequate exhaust ventilation and keep it meticulously clean. Outfit involved personnel with appropriate protective clothing and equipment.

7.1.2 For corrosive or otherwise hazardous chemicals, outfit involved personnel, as a minimum, with protective clothing and equipment.

7.2 Keep emergency equipment, such as a safety shower, eye wash, and self-contained breathing apparatus readily accessible to the test area.

7.3 A transparent safety shield (6.2.2) shall be present between the test cell and the observer.

7.4 Dispose of hazardous chemicals according to federal, state, and local regulations.

<sup>3</sup> The retaining screens listed are No. 9818T12, 9275T11 and 9218T12 respectively available from McMaster Carr Supply Co., P.O. Box 4335, Chicago, IL 60680.

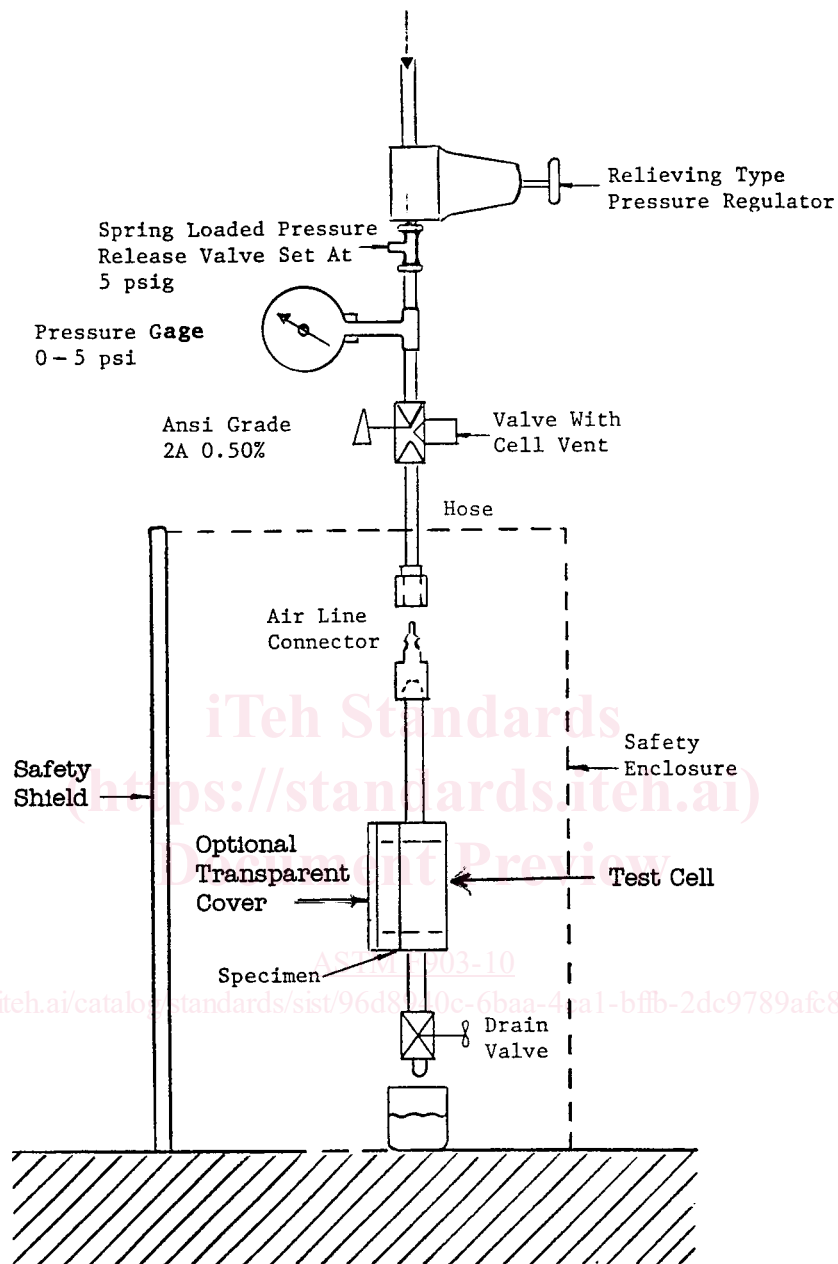

FIG. 1 Liquid Penetration Tester

**8. Test Specimen**

8.1 Specimens consist of either a single layer or a composite of multiple layers which is representative of an actual protective clothing material or construction with all layers arranged in proper order.

8.1.1 If in the design of an item of protective clothing, different materials or thickness of materials are specified at different locations, specimens from each location shall be selected.

8.1.2 If in the design, stitched-through or other type seams are specified, additional specimens containing such seams shall be tested.

8.2 Each material specimen to be tested shall have a minimum dimension of 2.5-in. ~~(65 mm)~~ (65 mm). A 2.75-in. ~~(70 mm)~~ (70 mm) square is convenient.

8.3 A minimum of three random specimens shall be tested for each material, composite, area (in the case of a heterogenous design), or other condition. Random specimens shall be generated as described in Practice E105.

**9. Procedure**

9.1 Using Test Method D1777 measure the appropriate thickness of each specimen to nearest 0.001 in. or ~~nearest~~ (nearest 0.02

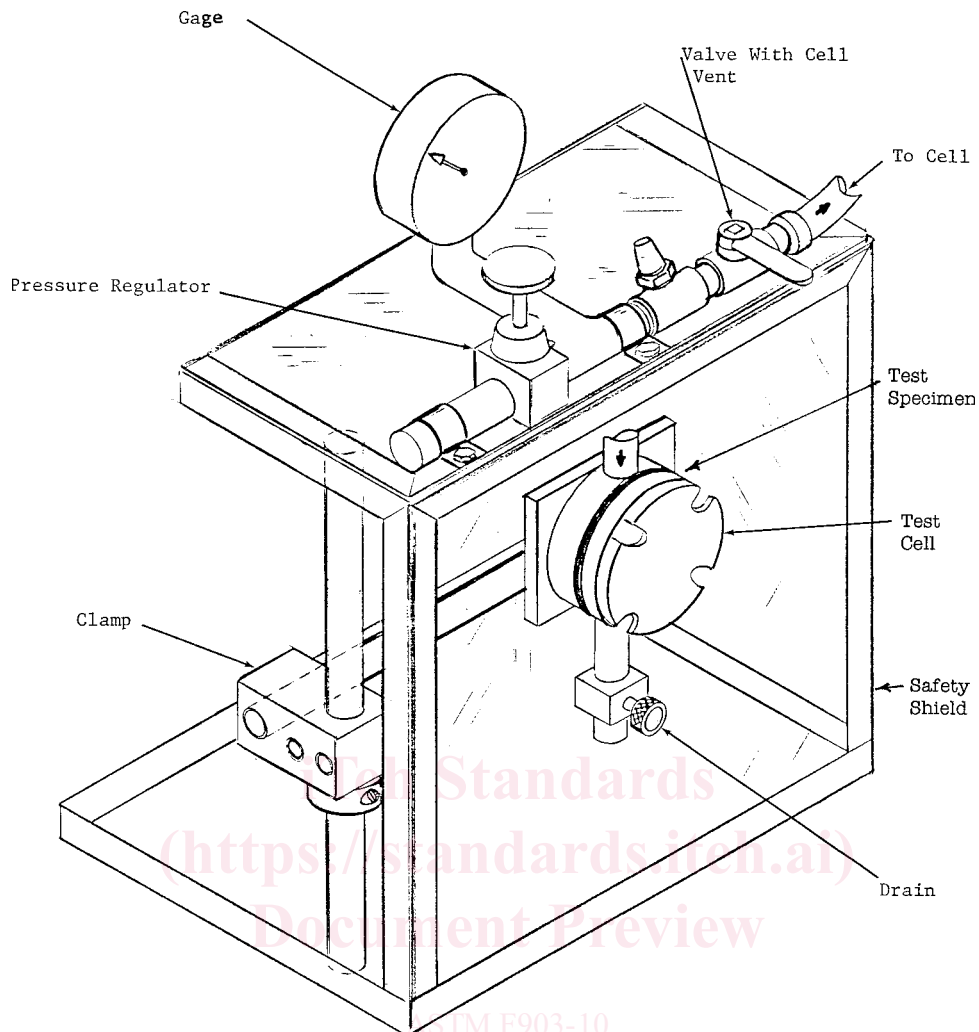

FIG. 2 Three-Dimensional Side View of the Test Apparatus

mm) and record. For nonuniform samples, record the lowest values.

9.2 Place a droplet of the challenge liquid on the normally inside surface of an extra piece of the material to be tested to predetermine the appearance of end point penetration. The droplet must remain easily visible to ensure that a droplet that penetrates the material will be seen. If not, one of the following methods has usually been effective in enhancing droplet visibility by producing a characteristic discoloration.

- 9.2.1 Apply talcum powder on the normally inside surface of the specimen.
- 9.2.2 Add food coloring, an acid-base indicator, or Oil Red to the challenge liquid.
- 9.2.3 Apply food coloring or Oil Red to the normally inside surface of the specimen.
- 9.2.4 Add a fluorescent dye to the challenge liquid.

NOTE 1—Contaminants in the colorant may change the surface energy of the challenge liquid and affect the test results

9.3 Mount the first specimen in the test cell with the normally outside surface toward the chemical chamber and assemble it as shown in Fig. 1. A transparent cover (see Fig. 3) is optionally mounted directly on the test cell as long as it does not alter the test results.

9.4 If the test is to be carried out at a nonambient temperature, place the assembled test cell in a constant temperature chamber at the test temperature. Also, bring the liquid to the test temperature.

9.5 Remove the male air line connector from the pipe nipple on the test cell. With the test cell vertically oriented, allowing the air to vent, carefully, fill the chamber of the test cell with enough challenge liquid to be sure the chamber remains full, even if the specimen distends when pressure is applied. Use of a funnel is one way to make filling the cell easier.

9.6 Attach the air line connector to the pipe nipple, and connect it to a source of pressure, making sure the valve is in the vent position.

9.7 Set the pressure regulator to 0-psig pressure and close the cell vent valve.

9.8 Expose the challenge liquid to the pressure(s) and for the time(s) called for in the procedure selected from Table 2, changing the pressure at the rate of no more than 0.5 psig/s [3.5 kPa/s]–(3.5 kPa/s).

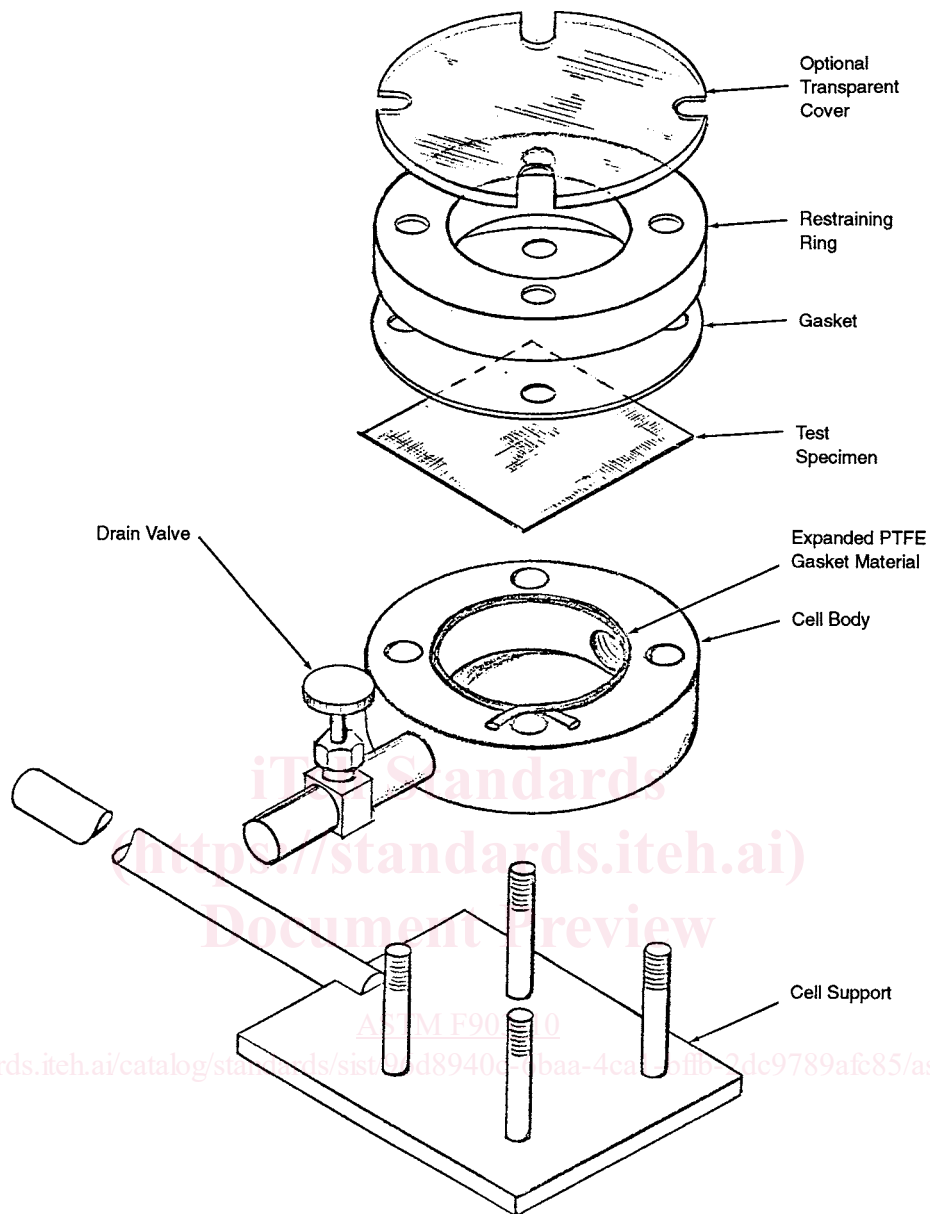

FIG. 3 Exploded View of the Penetration Test Cell

9.9 Observe the specimen. The specimen fails if a droplet of liquid appears or a characteristic discoloration (see 9.2) indicating the presence of the chemical appears on the viewing side of the specimen, or both. If this occurs, record the failure, and terminate the test.

9.9.1 If no liquid or characteristic discoloration appears for the duration of the test, record the specimen as passing.

9.9.2 In some cases the appearance of liquid or characteristic discoloration is caused by permeation of the chemical. If this occurs, record it as a failure and terminate the test.

9.10 At the conclusion of the test, relieve the test pressure and drain the chemical chamber. Flush the test cell with an appropriate wash liquid to remove or render harmless any traces of the test chemical. Remove the specimen and gasket from the cell and discard. Clean any external parts of the test cell touched by the liquid.

9.11 Test remaining specimens.

## 10. Report

10.1 State that the tests were conducted as directed in Test Method F903.

10.2 For each material tested, report the following information:

10.2.1 Type, supplier, and lot number of the material tested. If the material was taken from garments, report under subheadings for each material, composite, type of seam, or other constructions tested, and its position on the garment.

10.2.2 Thickness of each material specimen and the average thickness of the specimens tested.

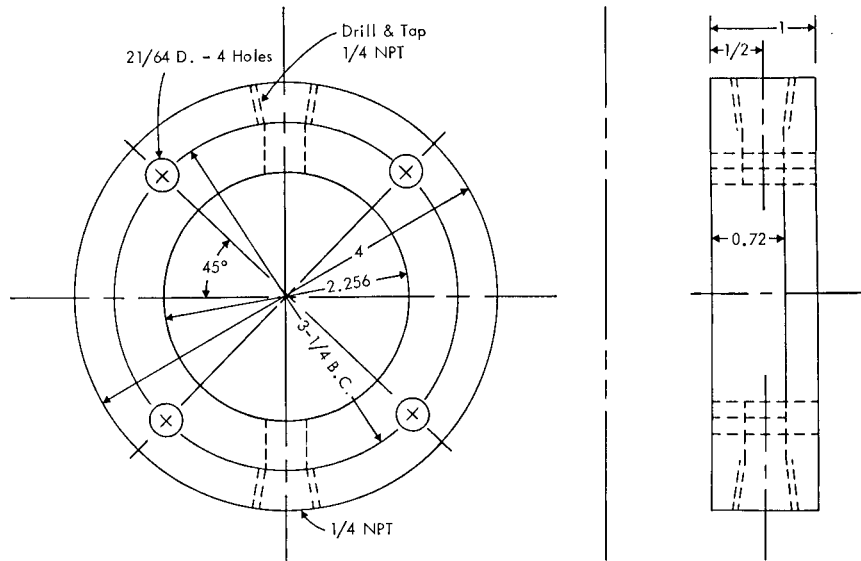

NOTE 1—All dimensions are in inches. (1 in. = 25.4 mm)

FIG. 4 Cell Body. Penetration Tester ASTM Committee F23.30, Material PTFE, or other suitable for Chemicals Used

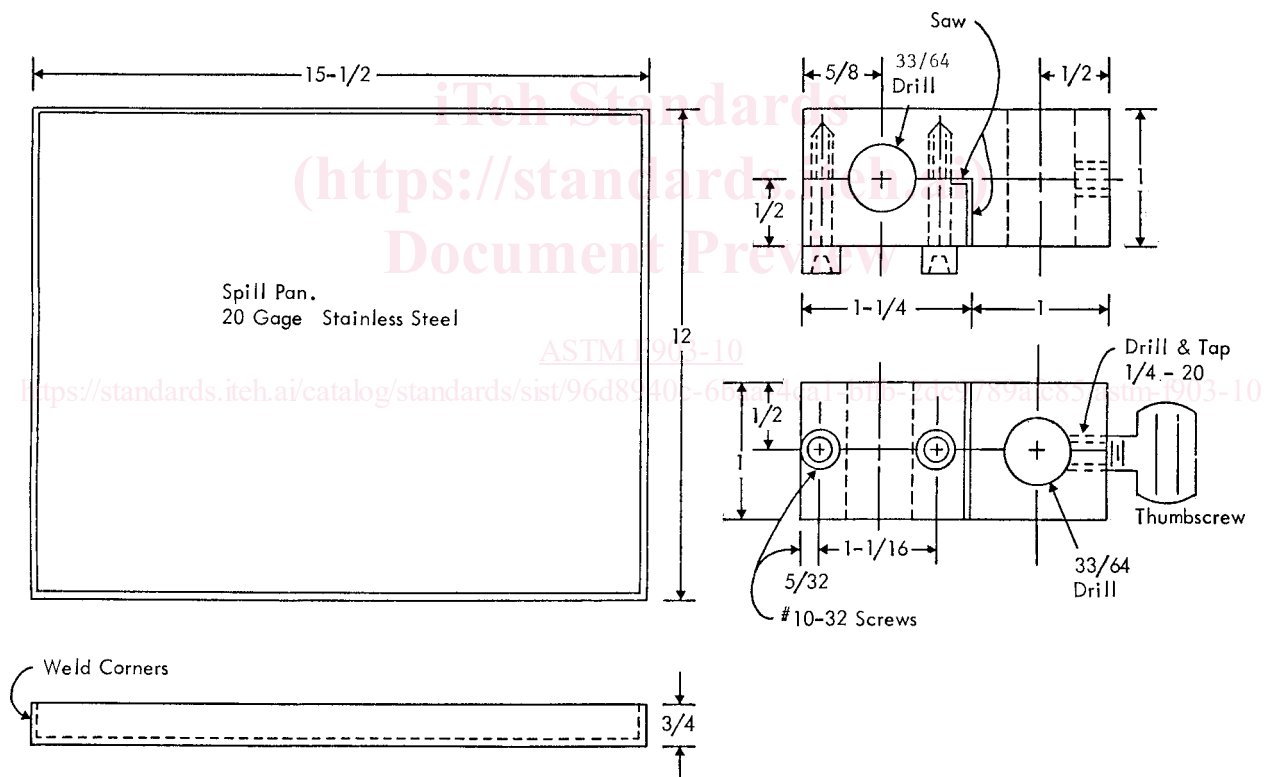

NOTE 1—All dimensions are in inches. (1 in. = 25.4 mm)

NOTE 2—Material is steel.

FIG. 5 Spill Pan and Swivel Clamp

10.2.3 Challenge liquid used.

10.2.4 Procedure used.

10.2.4.1 Procedure D is used, the time and pressure sequence must be noted in the test report.

10.2.5 Temperature at which the test was performed. If the temperature of the cell and liquid were different at the start of the test, report both.

10.2.6 Type, composition, and application procedure of the leak indicator, if one was used.

10.2.7 Penetration results as pass or fail for each specimen.