



SLOVENSKI STANDARD
SIST-TP CEN/TR 15120:2022

01-december-2022

Nadomešča:

SIST-TP CEN/TR 15120:2013

Cisterne za prevoz nevarnega blaga - Navodila in priporočila za polnjenje, prevoz in praznjenje

Tanks for transport of dangerous goods - Guidance and recommendations for loading, transport and unloading

Tanks für die Beförderung gefährlicher Güter - Leitlinien und Empfehlungen für Befüllung, Beförderung und Entladung

Citernes destinées au transport de matières dangereuses - Lignes directrices et recommandations pour le chargement, le transport et le déchargement

Ta slovenski standard je istoveten z: CEN/TR 15120:2022

ICS:

13.300	Varstvo pred nevarnimi izdelki	Protection against dangerous goods
23.020.20	Posode in vsebniki, montirani na vozila	Vessels and containers mounted on vehicles

SIST-TP CEN/TR 15120:2022 en

TECHNICAL REPORT

CEN/TR 15120

RAPPORT TECHNIQUE

TECHNISCHER REPORT

August 2022

ICS 13.300; 23.020.20

Supersedes CEN/TR 15120:2013

English Version

Tanks for transport of dangerous goods - Guidance and recommendations for loading, transport and unloading

Citernes destinées au transport de matières dangereuses - Lignes directrices et recommandations pour le chargement, le transport et le déchargement

Tanks für die Beförderung gefährlicher Güter - Leitlinien und Empfehlungen für Befüllung, Beförderung und Entladung

This Technical Report was approved by CEN on 22 August 2022. It has been drawn up by the Technical Committee CEN/TC 296.

CEN members are the national standards bodies of Austria, Belgium, Bulgaria, Croatia, Cyprus, Czech Republic, Denmark, Estonia, Finland, France, Germany, Greece, Hungary, Iceland, Ireland, Italy, Latvia, Lithuania, Luxembourg, Malta, Netherlands, Norway, Poland, Portugal, Republic of North Macedonia, Romania, Serbia, Slovakia, Slovenia, Spain, Sweden, Switzerland, Türkiye and United Kingdom.

iTeh STANDARD PREVIEW
(standards.iteh.ai)

[SIST-TP CEN/TR 15120:2022](https://standards.iteh.ai/catalog/standards/sist/46becb5f-02d3-4879-a541-1ab1d7a514af/sist-tp-cen-tr-15120-2022)

<https://standards.iteh.ai/catalog/standards/sist/46becb5f-02d3-4879-a541-1ab1d7a514af/sist-tp-cen-tr-15120-2022>



EUROPEAN COMMITTEE FOR STANDARDIZATION
COMITÉ EUROPÉEN DE NORMALISATION
EUROPÄISCHES KOMITEE FÜR NORMUNG

CEN-CENELEC Management Centre: Rue de la Science 23, B-1040 Brussels

Contents	Page
European foreword.....	4
Introduction	5
1 Scope	6
2 Normative references.....	6
3 Terms and definitions.....	6
4 Bottom loading gantry function and operation	6
4.1 Gantry loading equipment.....	6
4.2 Loading conditions	8
4.3 Loading operations.....	8
4.4 Permissive to load	9
5 Tank-vehicle type, function, and equipment	9
5.1 General.....	9
5.2 Tank-vehicle compartment identification.....	10
5.3 Tank-vehicle Control of static electricity	10
5.4 Tank-vehicle loading equipment	11
5.5 Vapour collection system.....	12
5.6 Breather devices and flame arresters	16
5.7 High level detection	18
5.8 Other tank-vehicle service equipment.....	18
5.9 Tank-vehicle safety systems	20
5.10 Metering and Tank contents measurement systems	21
6 Electrical equipment	21
7 Tank-vehicle data system interfaces.....	22
8 Conditions of operation.....	22
8.1 Weather conditions.....	22
8.2 Switch loading	22
8.3 Leak monitoring.....	22
9 Loading pass	22
10 Discharge	23
10.1 General.....	23
10.2 Site assessment.....	23
10.3 Control of electrical conductivity.....	24
10.4 Maximum delivery rates.....	24

10.5	Safety precautions.....	25
10.6	Checks prior to discharge.....	25
10.7	Discharge procedure.....	25
10.8	Frustrated deliveries	26
10.9	Completion of delivery	26
	Annex A (informative) Tank connection envelope.....	28
	Annex B (informative) Guidelines for the design, fabrication and testing of a vapour manifold..	32
	Annex C (informative) Information plate	38
	Annex D (informative) Overfill prevention sensor setting.....	40
	Annex E (informative) Illustration of when an explosive atmosphere might be present or might arise during loading operations	42
	Annex F (informative) Loading pass scheme.....	44
	Annex G (informative) Vehicles and compartments suitable for high-speed loading.....	48
	Annex H (informative) Loading velocity rates for road tankers	49
	Bibliography	50

iTeh STANDARD PREVIEW
(standards.iteh.ai)

[SIST-TP CEN/TR 15120:2022](https://standards.iteh.ai/catalog/standards/sist/46becb5f-02d3-4879-a541-1ab1d7a514af/sist-tp-cen-tr-15120-2022)

<https://standards.iteh.ai/catalog/standards/sist/46becb5f-02d3-4879-a541-1ab1d7a514af/sist-tp-cen-tr-15120-2022>

CEN/TR 15120:2022 (E)**European foreword**

This document (CEN/TR 15120:2022) has been prepared by Technical Committee CEN/TC 296 “Tanks for the transport of dangerous goods”, the secretariat of which is held by AFNOR.

Attention is drawn to the possibility that some of the elements of this document may be the subject of patent rights. CEN shall not be held responsible for identifying any or all such patent rights.

This document supersedes CEN/TR 15120:2013.

In comparison with the previous edition, the following technical modifications have been made:

Total revision including:

- Redraft to reflect current format rules;
- Development of recommendations on:
 - New mixtures and substances;
 - Protection against electrostatic hazards;
 - The difference between type 1 and type 2 tank-vehicle designs;
 - Vapour collection breather device operation;
 - Vapour Manifold Vent Valve operation;
 - Vapour manifold design, fabrication, and test;
- Revision of annexes.

Any feedback and questions on this document should be directed to the users’ national standards body. A complete listing of these bodies can be found on the CEN website.

Introduction

This document provides guidance and recommendations to enable the transfer of product and vapour between the loading gantry, the tank-vehicle, and the service station.

The European Parliament and Council Directive 94/63/EC (VOC Directive) [1] requires operators to ensure that petroleum vapours are not emitted into the atmosphere during loading and unloading. The recommendations and guidance given in this document are intended to assist users in meeting the requirements of this Directive.

This document acknowledges that, for historical, climatic, and logistical reasons, alternative technical solutions are commonly used nationally and in the Arctic Region.

iTeh STANDARD PREVIEW
(standards.iteh.ai)

[SIST-TP CEN/TR 15120:2022](https://standards.iteh.ai/catalog/standards/sist/46becb5f-02d3-4879-a541-1ab1d7a514af/sist-tp-cen-tr-15120-2022)

<https://standards.iteh.ai/catalog/standards/sist/46becb5f-02d3-4879-a541-1ab1d7a514af/sist-tp-cen-tr-15120-2022>

CEN/TR 15120:2022 (E)**1 Scope**

This document gives guidance and recommendations for loading at terminals and discharge at service stations or customer premises of tank-vehicles transporting dangerous substances of Class 3 of ADR – European Agreement concerning the International Carriage of Dangerous Goods by Road [2] – (flammable liquids) which have a vapour pressure not exceeding 110 kPa at 50 °C and petrol, and which have no sub-classification as toxic or corrosive.

2 Normative references

There are no normative references in this document.

3 Terms and definitions

No terms and definitions are listed in this document.

ISO and IEC maintain terminological databases for use in standardization at the following addresses:

- IEC Electropedia: available at <https://www.electropedia.org/>
- ISO Online browsing platform: available at <https://www.iso.org/obp>

4 Bottom loading gantry function and operation**4.1 Gantry loading equipment****4.1.1 General**

It is recommended that arrangements to permit loading of a tank-vehicle, equipped according to this document, are available to all gantries on loading facilities and at least one at each loading facility in arctic regions.

NOTE The arctic region comprises Denmark, Finland, Iceland, Norway and Sweden.

4.1.2 Overfill prevention – gantry meter pre-set

The primary overfill prevention system is provided by the pre-setting of the gantry loading meter by the tank-vehicle loader for each tank-vehicle compartment, separately, before it is loaded.

Therefore, it is recommended that bottom loading is only be permitted at gantries fitted with such pre-set meters to limit the volume loaded into each tank-vehicle compartment.

NOTE 1 Overfill is the filling of a tank-vehicle or one or more of its compartments to the extent that the total volume loaded into a compartment exceeds the maximum permitted volume for transport (see Annex D).

NOTE 2 Overloading is the loading of a tank-vehicle such that its total weight exceeds that permitted by local road regulations, or the load imposed by one or more axles exceeds the local maximum authorized weight for that axle and for a semi-trailer, when its coupling to the tractor is loaded to an extent that it exceeds its design load.

4.1.3 Overfill prevention – overfill prevention system (OPS)

The secondary overfill prevention system is provided by the overfill prevention system. The secondary system is a safety system which comes into operation when the primary system fails to operate.

To ensure interoperability, it is recommended that the gantry-based components of the overfill prevention system conform to EN 13922 [3].

Annex A shows the location envelope of the tank-vehicle socket.

NOTE The tank-vehicle component of the overfill prevention system (OPS) comprises the sensor or sensor circuits, and interface socket and all connecting wiring and cables.

The gantry component of the OPS comprises the interface plug, cable, and gantry controller which, when a sensor on the tank-vehicle detects liquid, provides an output to close the gantry control valve and stop product flow.

4.1.4 Coupler for bottom loading

For interoperability and safety reasons bottom loading gantries use couplers which are compatible with the adaptors for bottom loading (EN 13083 [4]) installed on the tank-vehicle.

Annex A shows the tank connection envelope of these adaptors on a tank-vehicle.

NOTE 1 This envelope is defined by the VOC Directive.

Tank-vehicles fitted with pressure balanced footvalves that close against product flow, may cause a surge pressure of 2 500 kPa within the loading coupler and pipework. It is important that loading facilities are capable of absorbing such surge pressures without compromise or loss of function.

NOTE 2 The type of foot valve (pressure balanced or non-pressure balanced) installed on the tank-vehicle is identified on an information plate attached to the tank-vehicle (see Annex C).

Loading facilities not capable of absorbing high surge pressures are not recommended to accept tank-vehicles fitted with pressure balanced footvalves.

To prevent the accumulation of any electrostatic charge, it is recommended that the electrical resistance across a metallic coupler and adaptor is less than 10 Ω , and less than 10⁶ Ω in other cases (e.g. non-metallic coupler/adaptor or devices isolated for product identification purposes), when connected.

NOTE 3 In the arctic region, couplers for bottom loading with the same functionality but able to connect with an adaptor for bottom loading with a reduced diameter are commonly used.

4.1.5 Vapour collection system

For interoperability and safety reasons bottom loading gantries use vapour collection couplers which are compatible with the vapour collection adaptors (EN 13081 [5]) installed on the tank-vehicle.

Annex A shows the tank connection envelope of these adaptors on a tank-vehicle.

NOTE 1 This envelope is defined by the VOC Directive.

For compliance with the VOC Directive, loading is not permitted unless the vapour collection hose has been connected to the vehicle and there is a free passage for the displaced vapours to flow from the tank-vehicle into the gantry's vapour collection system. This interlock may either use the overfill prevention system or be self-contained within the gantry's control system.

NOTE 2 In the arctic region, vapour collection couplers with the same functionality but with a reduced diameter are commonly used.

4.1.6 Unauthorized drive away restriction

It is recommended that methods to stop the unauthorized driving away of the tank-vehicle, either by means of a gantry installed system or a system integrated within the vehicle controls, are installed at each loading bay.

Whatever method is used, it is recommended that the restriction engages prior to and during loading and is only able to be released after completion of loading and once all loading arms and other gantry equipment are properly parked.

CEN/TR 15120:2022 (E)

4.2 Loading conditions

4.2.1 Maximum loading rates per loading arm

As noted in IEC/TS 60079-32-1:2013 [6], many operations with flammable liquids produce flammable atmospheres by evaporation of the liquid being handled. Where tanks are exposed to direct sunlight and liquid temperatures are not monitored it may be assumed that a flammable atmosphere could be present when handling liquids with flash points up to 60 °C. In areas of high ambient temperature and strong sunlight, flammable atmospheres may occur even with liquids that have flash points above 60 °C.

In some circumstances, the flammable atmosphere is not due to the liquid being handled but due to residues of volatile liquid or vapour from earlier operations with the same equipment or from nearby operations. Residual vapours may occur during switch loading, in which a liquid having a high flash point (e.g. diesel) is loaded into a tank which previously contained a liquid with a low flash point (e.g. petrol).

To minimize the danger of electrostatic hazards, IEC/TS 60079-32-1 recommends that, for petroleum products, the maximum product of velocity and pipe diameter (vd) is 0,5 m²/s subject to a maximum product loading velocity of 7 m/s.

For a conventional (100 mm) bottom loading system, this vd is equivalent to a maximum loading rate of 2 400 l/m (see Annex H).

It is also recommended that the tank-vehicle be suitable for high-speed loading (see 5.3.2).

NOTE Refer to IEC/TS 60079-32-1:2013, Clause 7 for more details of these recommendations, and for recommendations for other products and when new products are being considered for loading as their electrostatic criteria might be significantly different from that of the more conventional products. For example, conventional petroleum is classed as low conductivity whilst the addition of 10 % or more ethanol changes the classification to high conductivity.

To prevent static discharge caused by spraying at the footvalve, it is recommended that the loading rate is kept low until the footvalve is completely immersed in the product. Once the footvalve is fully submerged, the loading rate may then be increased.

4.2.2 Maximum liquid pressure

Where systems include valves that can be closed against the loading flow, including pressure-balanced valves, it is recommended that the maximum static pressure in the pipework upstream of these valves never exceeds 1 000 kPa (10 bar). (See 5.4.3).

4.2.3 Maximum vapour back pressure

The maximum back pressure created by the gantry vapour recovery system is 5,5 kPa (55 mbar). Controls may be provided by the terminal to ensure that this maximum back pressure is not exceeded, (e.g. limit the number of tank-vehicles being loaded simultaneously).

NOTE The maximum back pressure of 5,5 kPa is a requirement of the VOC Directive 94/63/EC.

4.3 Loading operations

4.3.1 General

It is recommended that, before loading is permitted, procedures exist to ensure that:

- there is authorization to load (see note); and
- the tank-vehicle is immobilized; and
- the loading of both empty and not-empty compartments is accommodated; and

- overloading, overfilling or contaminations do not occur; and
- an earthing cable is connected.

NOTE The authorization of a tank-vehicle loader by a terminal operator to load the required goods into the tank-vehicle follows the verification of his or her competence including any required certification and its associated validity.

4.3.2 Earthing cable

As noted in IEC/TS 60079-32-1:2013, the earthing cable, which is connected to the tank-vehicle during any loading operation, provides a resistance of less than 10 Ω between the tank-vehicle and the gantry's designated earthing point.

It is recommended that this earthing cable is part of a static earth monitoring system that continuously monitors the resistance between the tank-vehicle and the gantry's designated earthing point and activates interlocks to prevent loading when this resistance exceeds 10 Ω . It is also recommended that this earth monitoring system is be capable of differentiating between connection to the tank-vehicle's shell and any non-bonded metallic item.

It is recommended that an earthing connection is established before any other connections are made.

These functions may be provided by the overfill prevention system, through the plug/socket connection.

4.4 Permissive to load

It is recommended that product loading at a bottom loading vapour recovery gantry is permitted to commence only once the following conditions are met:

- Tank-vehicle is parked and confirmed to be suitable for loading the nominated products; and
- The earthing cable is connected; and
- Vapour path from tank compartment through to gantry recovery system is open; and
- Overfill prevention system is connected and provides a permissive signal; and
- Any other local condition (e.g. product identification system) is confirmed as operational.

5 Tank-vehicle type, function, and equipment

5.1 General

As noted in the Scope, this guidance covers tank-vehicles coded as LGBF by the regulations.

NOTE 1 See ADR clause 4.3.4.1.1 for the explanation of this coding.

The design of the tank shell may be in accordance with EN 13094 [7], EN 14025 [8] or any other approved procedure, however the coding will remain the same.

It is not recommended that tank shells manufactured from insulating materials are used for the transport of flammable liquids (see IEC/TS 60079-32-1:2013, 7.3.4.6).

These tank-vehicles are considered to have Gravity Discharge shells and, as the classification suggests, rely on gravity to fully discharge the liquid product. To prevent excessive VOC vapours being released to atmosphere, and to accommodate the expansion and contraction of the liquid product caused by atmospheric pressure and temperature change, these tanks are fitted with breather devices, and safety devices to prevent the contents from spilling out if the tank overturns.

CEN/TR 15120:2022 (E)

Gravity discharge tanks may also employ product approved cargo pumps to assist in the delivery process, however, such assistance is not permitted to pressurize the tank shell.

The breather devices may breathe to atmosphere either directly (type 1) or through the vapour manifold (type 2). (See 5.5.1).

These tank-vehicles may also be used for the transport of fuels containing bio substances which may not be classed as dangerous goods.

NOTE 2 If the product's flash point is above 60 °C then it is generally not classified as a dangerous good. Diesel, Heating oil and Gasoil are classified as dangerous goods if their flash point is between 60 °C and 100 °C.

In all cases, it is recommended that the Competent Authority's opinion is sought as to whether a product is a dangerous good or not, as different Nations may have different rules.

Examples of biofuels are:

- Biodiesel – composed of vegetable-based oil, usually fatty-acid esters. This can be combined with mineral-based diesel to produce a mixture, a fuel classed as B5 would contain 5 % biodiesel and 95 % mineral diesel. A fuel classed as B100 would be composed of 100 % biodiesel. Biodiesel has a higher flash point than mineral diesel. Biodiesel with a flash point above 100 °C is not classified as a dangerous goods. Biodiesel with a flash point below 100 °C and above 60 °C is classified as UN 1202.
- Bioethanol – composed of ethanol usually mixed with petrol. A fuel classed as E5 would contain 5 % ethanol and 95% petrol. Fuel classed as E100 would be composed of 100 % ethanol. Bioethanol is classed as a dangerous good. Where ethanol is more than 10 % of the fuel mixture but less than 100 %, the mixture is classified as UN3475. For mixtures with less than 10 % ethanol, classification would be UN1203 and if the mixture is 100 % ethanol, the classification is UN1170.
- Vegetable Oil – this has a flash point above 100 °C and is generally not classed as a dangerous good.

NOTE 3 Switch loading, and manifolded vapour recovery systems can result in the tank vehicle compartment containing a mixture of residual products and vapours. (See 8.2.)

5.2 Tank-vehicle compartment identification

It is recommended that the tank-vehicle compartments are clearly identified with their number and their maximum pre-set volume, starting from the front of the tank (see Annex C).

5.3 Tank-vehicle Control of static electricity

5.3.1 General

As an electrostatic charge is generated within the dangerous goods whenever they are being loaded into a tank-vehicle, it is recommended that precautions are taken to ensure the safe dissipation of the charge.

Typical precautions being:

- Electrical continuity between metal-to-metal connections to be 10 Ω or less.
- Non-metallic conductive components are installed such that electrical continuity of 10⁶ Ω or less exists across the interface to the adjacent component.
- Where the functionality of an electrical system requires one or more insulating blocks to be inserted between components, the electrical continuity across the components does not exceed 10⁶ Ω.
- the electrical continuity between the tank-vehicle shell and the chassis to be 10 Ω or less.

- The tank shell to be mounted such that there is electrical continuity of 1 000 Ω or less between the tank shell and wheel rims and 10⁶ Ω or less between the tank shell and a conductive road surface.
- Spray deflectors or other methods may be used to minimize spraying and jetting of liquid from the footvalves during the loading process.

NOTE The design of a footvalve bonnet or poppet might not provide a reliable means of determining whether, as installed, the jetting or spraying of product during loading will occur since it can also be dependent on the installation of the footvalve to its mounting flange and the flange to the tank.

5.3.2 Tank-vehicles suitable for high-speed loading

IEC/TS 60079-32-1:2013, 7.3.2.3.5.4, Table 11 specifies the requirements for a tank-vehicle to be classified as suitable for high-speed loading (this table is shown in Annex G).

5.3.3 Earthing

It is recommended that the tank-vehicle is fitted with an easily identifiable earth fitting to which an earthing cable, conforming to IEC/TS 60079-32-1, may be connected.

NOTE Reference can be made to ADR clause 6.8.2.1.27.

The earthing connection may be a separate cable (including clamp) or integrated with the overfill prevention system as described in EN 13922.

In the arctic region where the alternative 2 wire PTC thermistor is used, a separate static earthing cable is recommended.

5.4 Tank-vehicle loading equipment

5.4.1 Tank contents determination

For safety and operational purposes, it is important that the empty or not-empty condition of each tank-vehicle compartment and run-off pipework is determined prior to loading.

This may be achieved by means of sight glasses or wet-leg sensors with the footvalve open.

NOTE 1 An empty compartment contains less than 0,2 % of the compartment's nominal capacity or 5 l, whichever is the least.

NOTE 2 Metrological requirements might be more severe.

The use of product grade indicators is recommended.

5.4.2 Adaptor for bottom loading and unloading

It is recommended that the bottom loading adaptors conform to EN 13083. If the system is fitted with valves which can be closed against the loading flow, e.g. pressure balanced footvalves conforming to EN 13316 [9], then the adaptor coupler combination is to be capable of accommodating a surge pressure of 2 500 kPa without compromising their integrity or functions.

NOTE In the arctic region, bottom loading adaptors with the same functionality but with a reduced diameter are commonly used.

The location of the adaptors to allow the connection of couplers, are described in Annex A.

It is recommended that a plate is fitted adjacent to the adaptor identifying its compartment and the maximum (pre-set) volume of the compartment (see Annex C).

CEN/TR 15120:2022 (E)**5.4.3 Footvalves**

It is recommended that:

- Non-pressure balanced footvalves conform to EN 13308 [10];
- Pressure balanced footvalves conform to EN 13316;
- The tank-vehicle's control system ensures that a compartment's vapour transfer valve is opened before the compartment's footvalve, and that the footvalve is open before loading commences.
- For pipe systems with pressure balanced footvalves, a pressure relieving device is installed to prevent over-pressurization of the run-off pipework from thermal expansion of the liquid.

The opening pressure of this relieving device is to be less than the design pressure of the run-off pipe and within the region of 1 000 to 1 500 kPa.

NOTE Pressure balanced footvalves are typically used where:

- tank-vehicle controlled overfill prevention system is fitted; or
- tank-vehicle can be used for self-loading or topping-up away from a gantry; or
- a cross-over prevention system is fitted to prevent incorrect product being loaded into a non-empty compartment.

5.4.4 Cap for the bottom loading/unloading adaptor

It is recommended that the cap fitted to the bottom loading/unloading adaptor conforms to EN 16249 [11].

NOTE This cap is the third closure device reference in the tank coding (see 5.1).

5.4.5 Primary shutoff device

It is recommended that the pipe system requirements for tank-vehicles fitted with pressure balanced footvalves apply also to tank-vehicles fitted with pneumatically operated primary shutoff devices which also close against product flow.

5.5 Vapour collection system**5.5.1 General**

To ensure that vapour is not emitted to atmosphere when the terminal vapour collection system generates a backpressure of up to 5,5 kPa (55 mbar), it is recommended that care is taken when designing, operating, and maintaining the vapour collection system of the tank-vehicle.

For example:

- service equipment fitted to the compartment, vapour manifold and vapour pipework is designed and controlled such that vapours from the storage installations at the service stations or terminals are retained, except for the release of internal overpressure and vacuum through the breather device.

NOTE 1 The release of internal overpressure and vacuum through the breather device is permitted by the VOC Directive during transport.

- When bottom loading UN 1203 (petrol), the breather device pressure setting is sufficient to provide enough operating pressure to drive the returned vapour from the tanker-vehicle compartment, across the loading gantry and through the vapour recovery unit without releasing vapour from the tank-vehicle. (Recommended breather settings are given in 5.6.)

NOTE 2 With a maximum back pressure from the loading gantry of 55 mbar, type 1 tank-vehicles fitted with breather devices with an assured sealing pressure of 80 mbar, only provide a driving pressure of 25 mbar for the vapour from each compartment to the vapour adaptor. A breather device with a lower assured sealing pressure (less than 80 mbar) is unlikely to provide sufficient driving pressure for multi-arm loading.

- When delivering UN 1203 (petrol), the vacuum performance of the breather device is critical for reliable vapour balancing. (Recommended breather settings are given in 5.6.)

NOTE 3 When starting to deliver petrol from a tank-vehicle into a service station tank (typical volume 30 000 l), the rate of change of pressure in the large service station tank is relatively slow compared with the rate of change of vacuum in the road tanker compartment. The road tanker needs to draw vapour back into itself in preference to drawing air in through its breather device otherwise towards the end of the delivery, the displaced vapour from the service station will be expelled from the vent stack.

The vapour collection systems of tank-vehicles differ depending on whether they are of Type 1 or Type 2.

Type 1: The compartment breather device connects directly to atmosphere. See Figure 1.

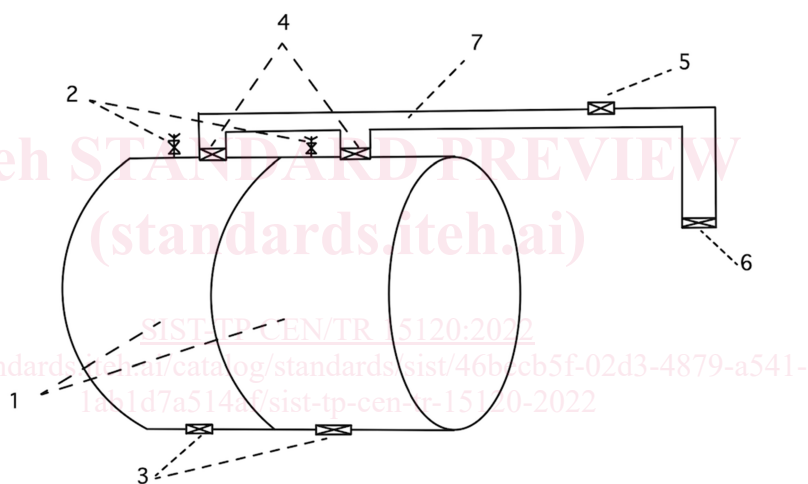

Key

- 1 tank compartment
- 2 breather device complete with safety device and flame arrester
- 3 compartment footvalve
- 4 compartment vapour transfer valve
- 5 vapour manifold vent valve
- 6 vapour adaptor

Figure 1 — Typical type 1 tank-vehicle vapour system