



Designation: C1206 – 02 (Reapproved2010)

# Standard Test Method for Plutonium by Iron (II)/Chromium (VI) Amperometric Titration<sup>1</sup>

This standard is issued under the fixed designation C1206; the number immediately following the designation indicates the year of original adoption or, in the case of revision, the year of last revision. A number in parentheses indicates the year of last reapproval. A superscript epsilon ( $\epsilon$ ) indicates an editorial change since the last revision or reapproval.

## 1. Scope

1.1 This test method covers the determination of plutonium in unirradiated nuclear-grade plutonium dioxide, uranium-plutonium mixed oxides with uranium (U)/plutonium (Pu) ratios up to 21, plutonium metal, and plutonium nitrate solutions. Optimum quantities of plutonium to measure are 7 to 15 mg.

1.2 The values stated in SI units are to be regarded as standard. No other units of measurement are included in this standard.

1.3 *This standard does not purport to address all of the safety concerns, if any, associated with its use. It is the responsibility of the user of this standard to establish appropriate safety and health practices and determine the applicability of regulatory limitations prior to use.*

## 2. Referenced Documents

2.1 *ASTM Standards:*<sup>2</sup>

C1168 Practice for Preparation and Dissolution of Plutonium Materials for Analysis

## 3. Committee C-26 Safeguards Statement

3.1 The materials [nuclear-grade mixed oxides (U, Pu)<sub>2</sub>O<sub>7</sub> powders, pellets, Pu metal, Pu oxides, and Pu nitrates] to which this test method applies, are subject to nuclear safeguards regulations governing their possession and use. This analytical test method has been designated as technically acceptable for generating safeguards accountability measurement data for plutonium.

3.2 When used in conjunction with appropriate standard reference material this test method can demonstrate traceability to the national measurement base. However, adherence to this

<sup>1</sup> This test method is under the jurisdiction of ASTM Committee C26 on Nuclear Fuel Cycle and is the direct responsibility of Subcommittee C26.05 on Methods of Test.

Current edition approved Jan. 1, 2010. Published February 2010. Originally approved in 1991. Last previous edition approved in 2002 as C1206 – 02. DOI: 10.1520/C1206-02R10.

<sup>2</sup> For referenced ASTM standards, visit the ASTM website, www.astm.org, or contact ASTM Customer Service at service@astm.org. For *Annual Book of ASTM Standards* volume information, refer to the standard's Document Summary page on the ASTM website.

test method does not automatically guarantee regulatory acceptance of the resulting safeguards measurements. It remains the sole responsibility of the user of this test method to ensure that its application to safeguards has the approval of the proper regulatory authorities.

## 4. Summary of Test Method

4.1 Amperometric titrations are based on the measured change in the current flow between two electrodes, held at constant potential, when a titrant is added. The plutonium is first oxidized to the +6 oxidation state in a dilute sulfuric acid solution with argentic oxide. The excess oxidant is destroyed by heating, and the Pu(VI) is then reduced to Pu(IV) by excess Fe(II) during the titration. The excess Fe(II) is titrated by Cr(VI), and the Pu determined by difference from the quantities of the two titrants.

4.2 Oxide and metal samples are prepared to produce final solutions as a soluble sulfate. Plutonium-nitrate solutions can be introduced directly at the beginning of the procedure and are later diluted with sulfuric acid. Chlorides must be removed.

## 5. Significance and Use

5.1 All plutonium materials covered in this test method are used in the preparation of nuclear-reactor fuels. In order to be suitable for this purpose, the materials must meet specified criteria for plutonium content. This test method is used to verify the plutonium content.

5.2 A primary standard dichromate such as that available from National Institute of Standards and Technology (NIST) or a dichromate traceable to a primary standard such as New Brunswick Laboratory (NBL) plutonium standard, is required for this technique.

## 6. Interferences

6.1 Interference is caused by ions that are oxidized by argentic oxide and reduced by ferrous ion in sulfuric-acid solution. Elements that may be present in plutonium materials and that will produce quantitative positive errors include vanadium (V), chromium (Cr), and manganese (Mn). Correction can be made for these elements by calculation when they do not individually exceed 200  $\mu\text{g}$  impurity elements per gram of plutonium.

6.2 Other elements that will cause positive errors include cerium (Ce), ruthenium (Ru), gold (Au), rhodium (Rh), platinum (Pt), lead (Pb), and neptunium (Np). Americium (Am) does not interfere because it is not oxidized to higher valency states during the argentic oxidation.

6.3 Thallium (Tl), selenium (Se), calcium (Ca), and barium (Ba) give low results.

## 7. Apparatus

7.1 *Weighing Burets*, polyethylene drop-dispenser bottles with polypropylene dropping closure and cap, 30 and 60-mL sizes.<sup>3</sup> Squeeze deliveries are made with these burets. They are placed in a secondary, cut-off, slightly larger diameter polyethylene bottle to prevent mass changes from contact with the hands. Burets are transferred to and from the balance using forceps.

7.2 *Digital Voltmeter*, d-c precision, readable to 0.2 mv.<sup>4</sup>

7.3 *Microelectrode*, rotating platinum.<sup>5</sup>

7.4 *Reference Mercury Electrode*, saturated mercurous sulfate.<sup>6</sup>

7.5 *Titration/Detector*, amperometric (see Fig. 1).

## 8. Reagents

8.1 *Purity of Reagents*—Reagent grade chemicals shall be used in all tests. Unless otherwise indicated, it is intended that all reagents conform to the specifications of the Committee on Analytical Reagents of the American Chemical Society where such specifications are available.<sup>7</sup> Other grades may be used, provided it is first ascertained that the reagent is of sufficient high purity to permit its use without lessening the accuracy of the determination.

8.2 *Purity of Water*—Unless otherwise indicated, references to water shall be understood to mean deionized or distilled water.

8.3 *Argentic Oxide (AgO)*.

<sup>3</sup> Nalgene drop-dispenser bottles, Nos. 2411-0030 and 2411-0060 have been found satisfactory. If you are aware of alternative suppliers, please provide this information to ASTM International Headquarters. Your comments will receive careful consideration at a meeting of the responsible technical committee,<sup>1</sup> which you may attend.

<sup>4</sup> Both Ealing Pye Scalamp Microammeter No. 29-222 and Keithley Model 197 Digital Multimeter have been found satisfactory. If you are aware of alternative suppliers, please provide this information to ASTM International Headquarters. Your comments will receive careful consideration at a meeting of the responsible technical committee,<sup>1</sup> which you may attend.

<sup>5</sup> Both Sargent & Co. No. S-30420 with No. S-76485 synchronous rotator and Brinkmann Model 2.628.0010 (628-10, 68-50) have been found satisfactory. If you are aware of alternative suppliers, please provide this information to ASTM International Headquarters. Your comments will receive careful consideration at a meeting of the responsible technical committee,<sup>1</sup> which you may attend.

<sup>6</sup> Brinkmann Model EA 406 has been found satisfactory. If you are aware of alternative suppliers, please provide this information to ASTM International Headquarters. Your comments will receive careful consideration at a meeting of the responsible technical committee,<sup>1</sup> which you may attend.

<sup>7</sup> *Reagent Chemicals, American Chemical Society Specifications*, American Chemical Society, Washington, DC. For suggestions on the testing of reagents not listed by the American Chemical Society, see *Analar Standards for Laboratory Chemicals*, BDH Ltd., Poole, Dorset, U.K., and the *United States Pharmacopeia and National Formulary*, U.S. Pharmacopeial Convention, Inc. (USPC), Rockville, MD.

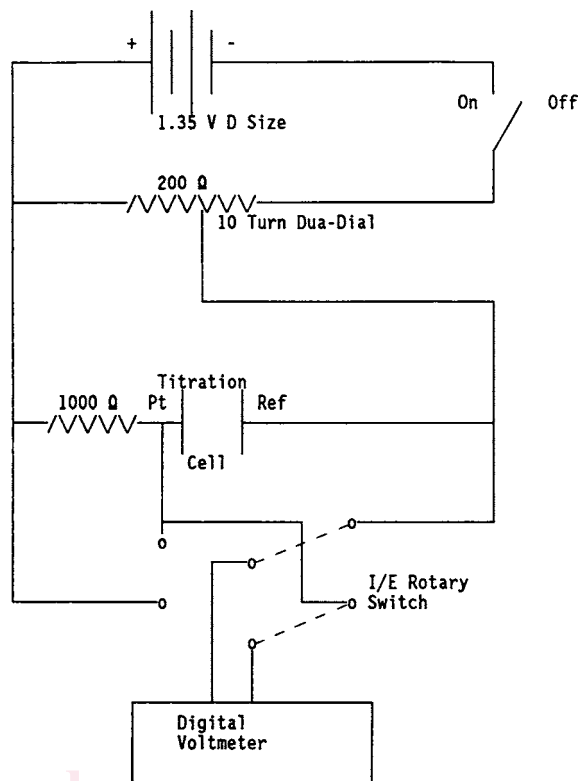

FIG. 1 Amperometric Detector Circuit

8.4 *Ferrous Ammonium Sulfate Solution, Iron (II) Titrant*—Dissolve 19.6 g of  $\text{Fe}(\text{NH}_4)_2(\text{SO}_4)_2 \cdot 6 \text{H}_2\text{O}$  in 500 mL of cold 1 N  $\text{H}_2\text{SO}_4$  and dilute to 1 L with 1 N  $\text{H}_2\text{SO}_4$ . The solution is standardized daily or before beginning a series of plutonium standard and sample titrations, or both.

8.5 *Potassium Dichromate Solution*—Use NIST SRM 136e<sup>8</sup> or equivalent. Weigh approximately 4.9 g to nearest 0.0001 g of potassium dichromate ( $\text{K}_2\text{Cr}_2\text{O}_7$ ) and dissolve in water. Transfer to a tared 2-L volumetric flask. Dilute to volume with water. Weigh the flask and contents. Make the buoyancy correction and determine the mass of the solution. Express the oxidizing strength as milliequivalents per gram of solution (C1).

$$C1 = \frac{K \times P \times B}{E \times S} \quad (1)$$

where:

C1 =  $\text{K}_2\text{Cr}_2\text{O}_7$  concentration, milliequivalents per gram,

K = weight, mg,  $\text{K}_2\text{Cr}_2\text{O}_7$ ,

P = purity of  $\text{K}_2\text{Cr}_2\text{O}_7$ ,

B = buoyancy correction for  $\text{K}_2\text{Cr}_2\text{O}_7$ , 1.00031 (use only if significant),

E = equivalent weight of  $\text{K}_2\text{Cr}_2\text{O}_7$ , 49.0320, and

S = weight of solution, g.

8.6 *Sulfuric Acid (0.5 N)*—Prepare by adding 14 mL of sulfuric acid ( $\text{H}_2\text{SO}_4$ , sp gr 1.84) to water with stirring and dilute to 1 L.

<sup>8</sup> Available from National Institute of Standards and Technology (NIST), 100 Bureau Dr., Stop 1070, Gaithersburg, MD 20899-1070, <http://www.nist.gov>.