



SLOVENSKI STANDARD SIST EN ISO 16808:2022

01-november-2022

Nadomešča:

SIST EN ISO 16808:2014

Kovinski materiali - Pločevina in trak - Ugotavljanje krivulje dvoosnega diagrama z izboklinskim preskusom optičnih merilnih sistemov (ISO 16808:2022)

Metallic materials - Sheet and strip - Determination of biaxial stress-strain curve by means of bulge test with optical measuring systems (ISO 16808:2022)

Metallische Werkstoffe - Blech und Band - Bestimmung der biaxialen Spannung/Dehnung-Kurve durch einen hydraulischen Tiefungsversuch mit optischen Messsystemen (ISO 16808:2022)

Matériaux métalliques - Tôles et bandes - Détermination de la courbe contrainte-déformation biaxiale au moyen de l'essai de gonflement hydraulique avec systèmes de mesure optiques (ISO 16808:2022)

Ta slovenski standard je istoveten z: EN ISO 16808:2022

ICS:

77.040.10	Mehansko preskušanje kovin	Mechanical testing of metals
77.140.50	Ploščati jekleni izdelki in polizdelki	Flat steel products and semi-products

SIST EN ISO 16808:2022

en,fr,de

EUROPEAN STANDARD

EN ISO 16808

NORME EUROPÉENNE

EUROPÄISCHE NORM

May 2022

ICS 77.040.10

Supersedes EN ISO 16808:2014

English Version

Metallic materials - Sheet and strip - Determination of biaxial stress-strain curve by means of bulge test with optical measuring systems (ISO 16808:2022)

Matériaux métalliques - Tôles et bandes -
Détermination de la courbe contrainte-déformation
biaxiale au moyen de l'essai de gonflement hydraulique
avec systèmes de mesure optiques (ISO 16808:2022)

Metallische Werkstoffe - Blech und Band - Bestimmung
der biaxialen Spannung/Dehnung-Kurve durch einen
hydraulischen Tiefungsversuch mit optischen
Messsystemen (ISO 16808:2022)

This European Standard was approved by CEN on 18 April 2022.

CEN members are bound to comply with the CEN/CENELEC Internal Regulations which stipulate the conditions for giving this European Standard the status of a national standard without any alteration. Up-to-date lists and bibliographical references concerning such national standards may be obtained on application to the CEN-CENELEC Management Centre or to any CEN member.

This European Standard exists in three official versions (English, French, German). A version in any other language made by translation under the responsibility of a CEN member into its own language and notified to the CEN-CENELEC Management Centre has the same status as the official versions.

CEN members are the national standards bodies of Austria, Belgium, Bulgaria, Croatia, Cyprus, Czech Republic, Denmark, Estonia, Finland, France, Germany, Greece, Hungary, Iceland, Ireland, Italy, Latvia, Lithuania, Luxembourg, Malta, Netherlands, Norway, Poland, Portugal, Republic of North Macedonia, Romania, Serbia, Slovakia, Slovenia, Spain, Sweden, Switzerland, Turkey and United Kingdom.



EUROPEAN COMMITTEE FOR STANDARDIZATION
COMITÉ EUROPÉEN DE NORMALISATION
EUROPÄISCHES KOMITEE FÜR NORMUNG

CEN-CENELEC Management Centre: Rue de la Science 23, B-1040 Brussels

Contents	Page
European foreword.....	3

iTeh STANDARD PREVIEW
(standards.iteh.ai)

[SIST EN ISO 16808:2022](https://standards.iteh.ai/catalog/standards/sist/6663dc23-fb5e-43d5-bc5a-aeaf7baa60f8/sist-en-iso-16808-2022)
<https://standards.iteh.ai/catalog/standards/sist/6663dc23-fb5e-43d5-bc5a-aeaf7baa60f8/sist-en-iso-16808-2022>

European foreword

This document (EN ISO 16808:2022) has been prepared by Technical Committee ISO/TC 164 "Mechanical testing of metals" in collaboration with Technical Committee CEN/TC 459/SC 1 "Test methods for steel (other than chemical analysis)" the secretariat of which is held by AFNOR.

This European Standard shall be given the status of a national standard, either by publication of an identical text or by endorsement, at the latest by November 2022, and conflicting national standards shall be withdrawn at the latest by November 2022.

Attention is drawn to the possibility that some of the elements of this document may be the subject of patent rights. CEN shall not be held responsible for identifying any or all such patent rights.

This document supersedes EN ISO 16808:2014.

Any feedback and questions on this document should be directed to the users' national standards body/national committee. A complete listing of these bodies can be found on the CEN website.

According to the CEN-CENELEC Internal Regulations, the national standards organizations of the following countries are bound to implement this European Standard: Austria, Belgium, Bulgaria, Croatia, Cyprus, Czech Republic, Denmark, Estonia, Finland, France, Germany, Greece, Hungary, Iceland, Ireland, Italy, Latvia, Lithuania, Luxembourg, Malta, Netherlands, Norway, Poland, Portugal, Republic of North Macedonia, Romania, Serbia, Slovakia, Slovenia, Spain, Sweden, Switzerland, Turkey and the United Kingdom.

(standards.iteh.ai)

Endorsement notice

SIST EN ISO 16808:2022

The text of ISO 16808:2022 has been approved by CEN as EN ISO 16808:2022 without any modification.

<https://standards.iteh.ai/catalog/standards/sist/6663dc23-fb5e-43d5-bc5a-aea17baa60f8/sist-en-iso-16808-2022>

INTERNATIONAL
STANDARD

ISO
16808

Second edition
2022-05

**Metallic materials — Sheet and strip
— Determination of biaxial stress-
strain curve by means of bulge test
with optical measuring systems**

*Matériaux métalliques — Tôles et bandes — Détermination de
la courbe contrainte-déformation biaxiale au moyen de l'essai de
gonflement hydraulique avec systèmes de mesure optiques*

iTeh STANDARD REVIEW
(standards.iteh.ai)

[SIST EN ISO 16808:2022](https://standards.iteh.ai/catalog/standards/sist/6663dc23-fb5e-43d5-bc5a-aeaf7baa60f8/sist-en-iso-16808-2022)

<https://standards.iteh.ai/catalog/standards/sist/6663dc23-fb5e-43d5-bc5a-aeaf7baa60f8/sist-en-iso-16808-2022>



Reference number
ISO 16808:2022(E)

© ISO 2022

iTeh STANDARD PREVIEW (standards.iteh.ai)

SIST EN ISO 16808:2022

<https://standards.iteh.ai/catalog/standards/sist/6663dc23-fb5e-43d5-bc5a-aeaf7baa60f8/sist-en-iso-16808-2022>



COPYRIGHT PROTECTED DOCUMENT

© ISO 2022

All rights reserved. Unless otherwise specified, or required in the context of its implementation, no part of this publication may be reproduced or utilized otherwise in any form or by any means, electronic or mechanical, including photocopying, or posting on the internet or an intranet, without prior written permission. Permission can be requested from either ISO at the address below or ISO's member body in the country of the requester.

ISO copyright office
CP 401 • Ch. de Blandonnet 8
CH-1214 Vernier, Geneva
Phone: +41 22 749 01 11
Email: copyright@iso.org
Website: www.iso.org

Published in Switzerland

Contents	Page
Foreword	iv
1 Scope	1
2 Normative references	1
3 Terms and definitions	1
4 Symbols and abbreviated terms	1
5 Principle	2
6 Test equipment	3
7 Optical measurement system	5
8 Test piece	6
8.1 General.....	6
8.2 Application of grid.....	6
8.2.1 Type of grid.....	6
8.2.2 Grid application.....	6
9 Procedure	6
10 Evaluation methods for the determination of the curvature and strains at the pole	7
11 Calculation of biaxial stress-strain curves	8
12 Test report	9
Annex A (informative) Test procedure for a quality check of the optical measurement system	11
Annex B (informative) Computation of the curvature on the basis of a response surface	14
Annex C (informative) Determination of the equi-biaxial stress point of the yield locus and the hardening curve	16
Bibliography	24

ISO 16808:2022(E)

Foreword

ISO (the International Organization for Standardization) is a worldwide federation of national standards bodies (ISO member bodies). The work of preparing International Standards is normally carried out through ISO technical committees. Each member body interested in a subject for which a technical committee has been established has the right to be represented on that committee. International organizations, governmental and non-governmental, in liaison with ISO, also take part in the work. ISO collaborates closely with the International Electrotechnical Commission (IEC) on all matters of electrotechnical standardization.

The procedures used to develop this document and those intended for its further maintenance are described in the ISO/IEC Directives, Part 1. In particular, the different approval criteria needed for the different types of ISO documents should be noted. This document was drafted in accordance with the editorial rules of the ISO/IEC Directives, Part 2 (see www.iso.org/directives).

Attention is drawn to the possibility that some of the elements of this document may be the subject of patent rights. ISO shall not be held responsible for identifying any or all such patent rights. Details of any patent rights identified during the development of the document will be in the Introduction and/or on the ISO list of patent declarations received (see www.iso.org/patents).

Any trade name used in this document is information given for the convenience of users and does not constitute an endorsement.

For an explanation of the voluntary nature of standards, the meaning of ISO specific terms and expressions related to conformity assessment, as well as information about ISO's adherence to the World Trade Organization (WTO) principles in the Technical Barriers to Trade (TBT), see www.iso.org/iso/foreword.html.

This document was prepared by Technical Committee ISO/TC 164, *Mechanical testing of metals*, Subcommittee SC 2, *Ductility testing*, in collaboration with the European Committee for Standardization (CEN) Technical Committee CEN/TC 459/SC 1, *Test methods for steel (other than chemical analysis)*, in accordance with the Agreement on technical cooperation between ISO and CEN (Vienna Agreement).

This second edition cancels and replaces the first edition (ISO 16808:2014), of which it constitutes a minor revision. The changes are as follows:

- the designation of $r_{1,100}$ in [Table 1](#) has been modified;
- the title of [Figure A.4](#) has been modified;
- [Formula \(B.2\)](#) has been modified;
- Annex A has been deleted and other annexes have been renumbered accordingly;
- the status of [Annex A](#) (formerly Annex B) has been changed to informative;
- minor editorial changes have been made to align with ISO/IEC Directives Part 2, 2021.

Any feedback or questions on this document should be directed to the user's national standards body. A complete listing of these bodies can be found at www.iso.org/members.html.

Metallic materials — Sheet and strip — Determination of biaxial stress-strain curve by means of bulge test with optical measuring systems

1 Scope

This document specifies a method for determination of the biaxial stress-strain curve of metallic sheets having a thickness below 3 mm in pure stretch forming without significant friction influence. In comparison with tensile test results, higher strain values can be achieved.

NOTE In this document, the term "biaxial stress-strain curve" is used for simplification. In principle, in the test the "biaxial true stress-true strain curve" is determined.

2 Normative references

There are no normative references in this document.

3 Terms and definitions

No terms and definitions are listed in this document.

ISO and IEC maintain terminology databases for use in standardization at the following addresses:

- ISO Online browsing platform: available at <https://www.iso.org/obp>
- IEC Electropedia: available at <http://www.electropedia.org/>

4 Symbols and abbreviated terms

The symbols and designations used are given in [Table 1](#).

Table 1

Symbol	Designation	Unit
d_{die}	Diameter of the die (inner)	mm
d_{BH}	Diameter of the blank holder (inner)	mm
R_1	Radius of the die (inner)	mm
h	Height of the drawn blank (outer surface)	mm
t_0	Initial thickness of the sheet (blank)	mm
t	Actual thickness of the sheet	mm
p	Pressure in the chamber	MPa
rms	Standard deviation (root mean square)	-
ρ	Radius of curvature	mm
r_1	Surface radius for determining curvature	mm
r_2	Surface radius for determining strain	mm
r_{1_100}	Surface radius to determine curvature with a diameter of 100 mm	mm
a_i, b_i	Coefficients for response surface	-

Table 1 (continued)

Symbol	Designation	Unit
σ_B	Biaxial stress	MPa
e	Engineering strain	-
ε_1	Major true strain	-
ε_2	Minor true strain	-
ε_3	True thickness strain	-
ε_E	Equivalent true strain	-
l_s	Coordinate and length of a section	mm
dz	Displacement in the z-direction	mm
dz_{mv}	Displacement after movement correction	mm

5 Principle

A circular blank is completely clamped at the edge in a tool between die and blank holder. A bulge is formed by pressing a fluid against the blank until final fracture occurs (Figure 1). During the test, the pressure of the fluid is measured and the evolution of the deformation of the blank is recorded by an optical measuring system [1], [2], [3]. Based on the recorded deformation of the blank, the following quantities near the centre of the blank are determined: the local curvature, the true strains at the surface, and, by assuming incompressible deformation of the material, the actual thickness of the blank. Furthermore, assuming the stress state of a thin-walled spherical pressure vessel at the centre of the blank, the true stress is calculated from the fluid pressure, the thickness and the curvature radius.

NOTE In addition to the bulge test procedures with optical measurement systems introduced in Reference [1] and described in the following, there are also laser systems [4], [5], [6] or tactile systems [7], [8], [9] valid for bulge test investigation, which are not covered in this document.

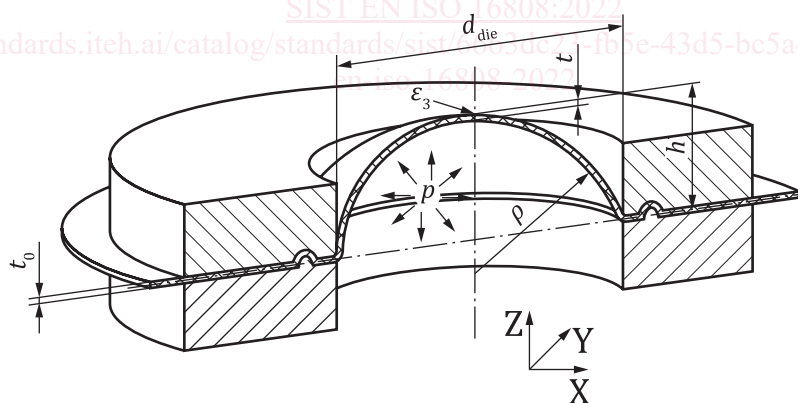

Key

h	height of the drawn blank (outer surface)	ρ	radius of curvature
p	pressure in the chamber	t_0	initial thickness of the sheet (blank)
ε_3	true thickness strain (at the apex of the dome)	t	actual thickness of the sheet
d_{die}	diameter of the die (inner)		

Figure 1 — Principle of the bulge test

The coordinate origin shall be in the centre of the blank holder. The XY-plane should be parallel to the surface of the blank holder (parallel to the clamped metal sheet before forming). Herein, the x-direction corresponds to the rolling direction. The z-direction shall be normal to the clamped metal sheet before forming, with the positive direction towards the optical sensor.