



Designation: E384 – 10^{ε1}

Standard Test Method for Knoop and Vickers Hardness of Materials¹

This standard is issued under the fixed designation E384; the number immediately following the designation indicates the year of original adoption or, in the case of revision, the year of last revision. A number in parentheses indicates the year of last reapproval. A superscript epsilon (ϵ) indicates an editorial change since the last revision or reapproval.

This standard has been approved for use by agencies of the Department of Defense.

^{ε1} NOTE—The title was editorially revised in March 2010.

1. Scope*

1.1 This test method covers determination of the Knoop and Vickers hardness of materials, the verification of Knoop and Vickers hardness testing machines, and the calibration of standardized Knoop and Vickers test blocks.

1.2 This test method covers Knoop and Vickers hardness tests made utilizing test forces in micro (9.807×10^{-3} to 9.807 N) (1 to 1000 gf) and macro (>9.807 to 1176.68 N) (>1kg to 120 kgf) ranges.

NOTE 1—Previous versions of this standard limited test forces to 9.807 N (1 kg).

1.3 This test method includes all of the requirements to perform macro Vickers hardness tests as previously defined in Test Method E92, Standard Test Method for Vickers Hardness Testing.

1.4 This test method includes an analysis of the possible sources of errors that can occur during Knoop and Vickers testing and how these factors affect the accuracy, repeatability, and reproducibility of test results.

NOTE 2—While Committee E04 is primarily concerned with metals, the test procedures described are applicable to other materials.

1.5 *Units*—When Knoop and Vickers hardness tests were developed, the force levels were specified in units of grams (gf) and kilograms-force (kgf). This standard specifies the units of force and length in the International System of Units (SI); that is, force in Newtons (N) and length in mm or μm . However, because of the historical precedent and continued common usage, force values in gf and kgf units are provided for information and much of the discussion in this standard as well as the method of reporting the test results refers to these units.

¹ This test method is under the jurisdiction of ASTM Committee E04 on Metallography and is the direct responsibility of Subcommittee E04.05 on Micro-indentation Hardness Testing. With this revision the test method was expanded to include the requirements previously defined in E28.92, Standard Test Method for Vickers Hardness Testing of Metallic Material that was under the jurisdiction of E28.06

Current edition approved Feb. 1, 2010. Published February 2010. Originally approved in 1969. Last previous edition approved in 2009 as E384 – 09. DOI: 10.1520/E0384-10.

1.6 *This standard does not purport to address all of the safety concerns, if any, associated with its use. It is the responsibility of the user of this standard to establish appropriate safety and health practices and determine the applicability of regulatory limitations prior to use.*

2. Referenced Documents

2.1 ASTM Standards:²

C1326 Test Method for Knoop Indentation Hardness of Advanced Ceramics

C1327 Test Method for Vickers Indentation Hardness of Advanced Ceramics

E3 Guide for Preparation of Metallographic Specimens

E7 Terminology Relating to Metallography

E29 Practice for Using Significant Digits in Test Data to Determine Conformance with Specifications

E74 Practice of Calibration of Force-Measuring Instruments for Verifying the Force Indication of Testing Machines

E92 Test Method for Vickers Hardness of Metallic Materials

E122 Practice for Calculating Sample Size to Estimate, With Specified Precision, the Average for a Characteristic of a Lot or Process

E140 Hardness Conversion Tables for Metals Relationship Among Brinell Hardness, Vickers Hardness, Rockwell Hardness, Superficial Hardness, Knoop Hardness, and Scleroscope Hardness

E175 Terminology of Microscopy

E177 Practice for Use of the Terms Precision and Bias in ASTM Test Methods

E691 Practice for Conducting an Interlaboratory Study to Determine the Precision of a Test Method

E766 Practice for Calibrating the Magnification of a Scanning Electron Microscope

² For referenced ASTM standards, visit the ASTM website, www.astm.org, or contact ASTM Customer Service at service@astm.org. For *Annual Book of ASTM Standards* volume information, refer to the standard's Document Summary page on the ASTM website.

*A Summary of Changes section appears at the end of this standard.

2.2 ISO Standards:³

ISO 6507-1 Metallic Materials—Vickers hardness Test—Part 1: Test Method

ISO/IEC 17011 Conformity Assessment—General Requirements for Accreditation Bodies Accrediting Conformity Assessment Bodies.

ISO/IEC 17025 General Requirements for the Competence of Testing and Calibration Laboratories

recovery after force removal. The test results are normally in the Knoop or Vickers scales.

3.2.5 *macroindentation hardness test, n*—a hardness test using a calibrated machine to force an indenter of specific geometry into the surface of the material being evaluated, in which the test forces are normally higher than 9.807 N (1 kgf). Macroindentation test scales include Vickers, Rockwell and Brinell.

NOTE 3—Use of the term microhardness should be avoided because it implies that the hardness, rather than the force or the indentation size, is very low.

3.2.6 *verifying, v*—checking or testing the instrument to assure conformance with the specification.

3.2.7 *Vickers hardness number, HV, n*—an expression of hardness obtained by dividing the force applied to a Vickers indenter by the surface area of the permanent impression made by the indenter.

3.2.8 *Vickers indenter, n*—a square-based pyramidal-shaped diamond indenter with face angles of 136° (see Fig. 1).

3.2.9 *scale, n*—a specific combination of indenter (Knoop or Vickers) and the test force. For example, HV10 is a scale defined as using a Vickers indenter and a 10kg test force and HK0.1 is a scale defined as using a Knoop indenter and a 100gf test force. See 5.8 for the proper reporting of the hardness level and scale.

3.3 *Formulae*—The formulae presented in 5.5 and 5.6 for calculating Knoop and Vickers hardness are based upon an ideal tester. The measured value of the Knoop and Vickers hardness of a material is subjected to several sources of errors. Based on Eq 1-9, variations in the applied force, geometrical variations between diamond indenters, and human errors in measuring indentation lengths can affect the calculated material hardness. The amount influence each of these parameters

3. Terminology

3.1 *Definitions*—For the standard definitions of terms used in this test method, see Terminology E7.

3.2 *Definitions of Terms Specific to This Standard:*

3.2.1 *calibrating, v*—determining the values of the significant parameters by comparison with values indicated by a reference instrument or by a set of reference standards.

3.2.2 *Knoop hardness number, HK, n*—an expression of hardness obtained by dividing the force applied to the Knoop indenter by the projected area of the permanent impression made by the indenter.

3.2.3 *Knoop indenter, n*—a rhombic-based pyramidal-shaped diamond indenter with edge angles of ∠ A = 172° 30' and ∠ B = 130° 0' (see Fig. 2).

3.2.4 *microindentation hardness test, n*—a hardness test using a calibrated machine to force a diamond indenter of specific geometry into the surface of the material being evaluated, in which the test forces are 9.807×10^{-3} to 9.807 N (1 to 1000 gf) and the indentation diagonal, or diagonals are measured with a light microscope after load removal; for any test, it is assumed that the indentation does not undergo elastic

³ Available from International Organization for Standardization (ISO), 1, ch. de la Voie-Creuse, Case postale 56, CH-1211, Geneva 20, Switzerland, <http://www.iso.org>.

<https://standards.iteh.ai/catalog/standards/sist/39e1cae3-fd4b-4c39-883c-a48c3457032c/astm-e384-10e1>

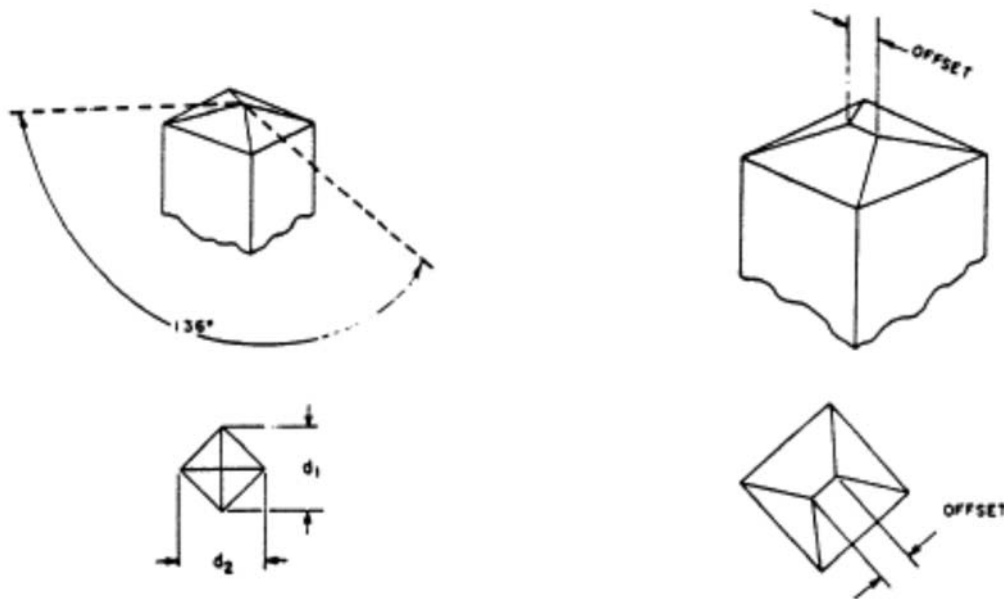

FIG. 1 Vickers Indenter

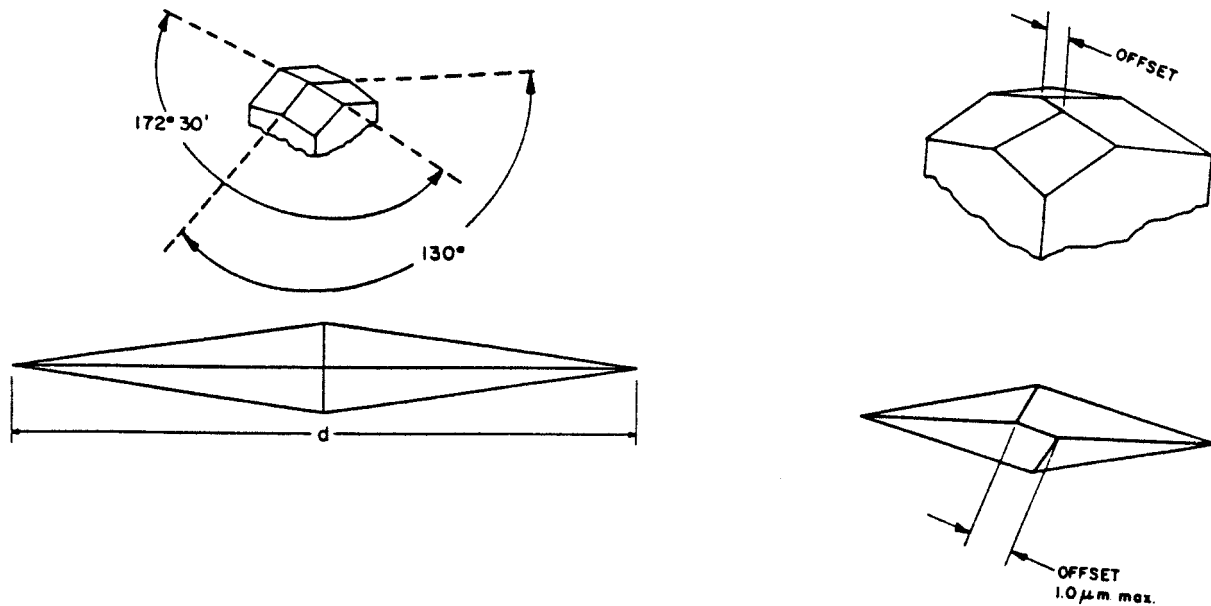

FIG. 2 Knoop Indenter

has on the calculated value of a Knoop or Vickers measurement is discussed in Section 10.

4. Significance and Use

4.1 Hardness tests have been found to be very useful for materials evaluation, quality control of manufacturing processes and research and development efforts. Hardness, although empirical in nature, can be correlated to tensile strength for many metals, and is an indicator of wear resistance and ductility.

4.2 Microindentation hardness tests extend testing to materials that are too thin or too small for macroindentation hardness tests. Microindentation hardness tests also allow specific phases or constituents and regions or gradients too small for macroindentation hardness testing to be evaluated.

4.3 Because the Knoop and Vickers hardness will reveal hardness variations that may exist within a material, a single test value may not be representative of the bulk hardness.

4.4 The Vickers indenter usually produces a geometrically similar indentation at all test forces. Except for tests at very low forces that produce indentations with diagonals smaller than about 25 μm, the hardness number will be essentially the same as produced by Vickers machines with test forces greater than 1 kgf, as long as the material being tested is reasonably homogeneous. For isotropic materials, the two diagonals of a Vickers indentation are equal in size. Recommendations for low force microindentation testing can be found in Appendix X5.

4.5 The Knoop indenter does not produce a geometrically similar indentation as a function of test force. Consequently, the Knoop hardness will vary with test force. Due to its rhombic shape, the indentation depth is shallower for a Knoop indentation compared to a Vickers indentation under identical test conditions. The two diagonals of a Knoop indentation are markedly different. Ideally, the long diagonal is 7.114 times longer than the short diagonal, but this ratio is influenced by

elastic recovery. Thus, the Knoop indenter is very useful for evaluating hardness gradients or thin coatings of sectioned samples.

5. Principle of Test

5.1 In this test method, a Knoop or Vickers hardness number is determined based on the formation of a relatively small indentation made in the test surface of samples being evaluated.

5.2 A Knoop or Vickers indenter, made from diamond of specific geometry, is pressed into the test specimen surface by an accurately controlled applied force using test machines specifically designed for such work.

5.3 Knoop and Vickers hardness testing is divided into micro and macro-test force ranges as defined:

Range	Test Force
Micro	Micro 9.807×10^{-3} to ≤ 9.807 N (1 to ≤ 1000 gf)
Macro	Macro > 9.807 to ≤ 1176.68 N (> 1 to ≤ 120 kgf)

5.3.1 Knoop scale testing is normally performed using micro-range test forces (1kg and less) while the Vickers scale is used over both the micro and macro-ranges.

NOTE 4—The user should consult with the manufacturer before applying test forces in the macro-ranges (over 1 kg) with diamond indenters previously used for micro-range testing. The diamond mount may not be strong enough to support the higher test forces and the diamond may not be large enough to produce the larger indent sizes.

5.4 The size of the indentation is measured using a light microscope equipped with a filar type eyepiece, or other type of measuring device (see Terminology E175). Micro-range indents are typically measured in μm (micrometers) and macro-range indents are measured in mm. The formulas for both units are given below.

5.5 The Knoop hardness number is based upon the force divided by the projected area of the indentation

5.5.1 For Knoop hardness testing, test loads are typically in grams-force (gf) and indentation diagonals are in micrometers

(m). The Knoop hardness number, in terms of gf and μm , is calculated using the following:

$$HK = 1.000 \times 10^3 \times (P/A_p) = 1.000 \times 10^3 \times P/(c_p \times d^2) \quad (1)$$

or

$$HK = 14229 \times P/d^2 \quad (2)$$

$$\text{Indenter constant} = c_p = \frac{\tan \frac{\angle B}{2}}{2 \tan \frac{\angle A}{2}} \quad (3)$$

where:

- P = force, gf,
- d = length of long diagonal, μm^2 ,
- A_p = projected area of indentation,
- $\angle A$ = included longitudinal edge angle, $172^\circ 30'$
- $\angle B$ = included transverse edge angle, $130^\circ 0'$ (see Fig. 2 and,
- c_p = indenter constant relating projected area of the indentation to the square of the length of the long diagonal, ideally 0.07028.

NOTE 5—HK values for a 1-gf (9.807×10^{-3} N) test force are contained in Appendix X6. To obtain HK values when other test forces are employed, multiply the HK value from Table X6.1 for the d value by the actual test force, g.

5.5.2 The Knoop hardness, in terms of kgf and mm, is determined as follows:

$$HK = 14.229 \times P_1/d_1^2 \quad (4)$$

where:

- P_1 = force, kgf, and
- d_1 = length of long diagonal, mm.

5.5.3 The Knoop hardness reported with units of GPa is determined as follows:

$$HK = 0.014229 \times P_2/d_2^2 \quad (5)$$

where:

- P_2 = force, N, and
- d_2 = length of the long diagonal of the indentation, mm.

5.6 The Vickers hardness number is based upon the force divided by the surface area of the indentation.

5.6.1 For the micro-range Vickers hardness test loads are typically in grams-force (gf) and indentation diagonals are in micrometers (μm). The Vickers hardness number, in terms of gf and μm , is calculated as follows:

$$HV = 1.000 \times 10^3 \times P/A_s = 2.000 \times 10^3 \times P \sin(\alpha/2)/d^2 \quad (6)$$

or

$$HV = 1854.4 \times P/d^2 \quad (7)$$

where:

- P = force, gf,
- A_s = surface area of the indentation, μm^2 ,
- d = mean diagonal length of the indentation, μm , and
- α = face angle of the indenter, $136^\circ 0'$ (see Fig. 1).

NOTE 6—HV numbers for a 1-gf (9.807×10^{-3} N) test load are contained in Appendix X6. To obtain HV values when other test forces are

employed, multiply the HV value from Table X6.2 for the d value by the actual test force, g.

5.6.2 Macro range Vickers hardness is typically determined using kgf and mm and is calculated as follows:

$$HV = 1.8544 \times P_1/d_1^2 \quad (8)$$

where:

- P_1 = force, kgf, and
- d_1 = mean diagonal length of the indentations, mm.

5.6.3 The Vickers hardness reported with units of GPa is determined as follows:

$$HV = 0.0018544 \times P_2/d_2^2 \quad (9)$$

where:

- P_2 = force, N, and
- d_2 = mean diagonal length of the indentations, mm.

5.7 It is assumed that elastic recovery does not occur when the indenter is removed after the loading cycle. That is, it is assumed that the indentation retains the shape of the indenter after the force is removed. In Knoop testing, it is assumed that the ratio of the long diagonal to the short diagonal of the impression is the same as for the indenter.

5.8 The symbols HK for Knoop hardness, and HV for Vickers hardness shall be used with the reported numerical values.

5.8.1 For this standard, the hardness test results can be reported in several different ways. For example, if the Knoop hardness was found to be 400, and the test force was 100 gf, the test results may be reported as follows:

5.8.1.1 In the kilogram force system: 400 HK 0.1.

5.8.1.2 In the gram force system: 400 HK 100 gf.

5.8.1.3 In the SI system: 3.92 GPa.

5.8.1.4 For nonstandard dwell times, other than 10 to 15 s, the hardness would be reported as 400 HK 0.1/22. In this case, 22 would be the actual time of full load dwell time in seconds.

5.9 The reported Knoop and Vickers hardness number shall be reported rounded to three significant digits in accordance with Practice E29 (for example, 725 HV 0.1, 99.2 HK 1).

6. Apparatus

6.1 *Test Machine*—The test machine shall support the test specimen and control the movement of the indenter into the specimen under a preselected test force, and should have a light optical microscope to select the desired test location and to measure the size of the indentation produced by the test. The plane of the surface of the test specimen should be perpendicular to the axis of the indenter and the direction of the force application.

6.1.1 *Vibration Control*—During the entire test cycle, the test machine should be protected from shock or vibration. To minimize vibrations, the operator should avoid contacting the machine in any manner during the entire test cycle.

6.2 *Vickers Indenter*—The ideal Vickers indenter (see Fig. 1) is a highly polished, pointed, square-based pyramidal diamond with face angles of $136^\circ 0'$. The effect that geometrical variations of these angles have on the measured values of Vickers hardness are discussed in Section 10.

6.2.1 The four faces of the Vickers indenter shall be equally inclined to the axis of the indenter and shall meet at a sharp

point. The line of junction (offset) between opposite faces shall not exceed the limits defined in **A1.3.5.1**.

6.3 Knoop Indenter—The ideal Knoop (see **Fig. 2**) indenter is a highly polished, pointed, rhombic-based, pyramidal diamond. The included longitudinal edge angles are 172° 30' and 130° 0'. The ideal indenter constant, c_p , is 0.07028. The effect that geometrical variations of these angles have on the measured values of Knoop hardness are discussed in **Section 10**.

6.3.1 The four faces of the Knoop indenter shall be equally inclined to the axis of the indenter and shall meet at a sharp point. The line of junction (offset) between opposite faces shall not exceed the limits defined in **A1.3.5.2**.

6.4 Measuring Equipment—The measuring device shall be capable of reporting the diagonal lengths to within 0.5µm or 0.5% whichever is larger. For microindentation hardness testing the measuring device should be able to report the diagonal lengths in 0.1 µm increments.

NOTE 7—This is the reported length and not the resolution of the system used for performing the measurements. As an example, if a length of 200 µm corresponds to 300 filar units or pixels, the corresponding calibration constant would be 200/300 = 0.667. This value would be used to compute diagonal lengths, but the reported length would only be reported to the nearest 0.5 or 0.1 µm.

6.4.1 the measuring device may be an integral part of the tester or a stand alone instrument.

6.4.2 The optical portion of the measuring device should have Köhler illumination (see **Appendix X1**).

6.4.3 To obtain maximum resolution, the measuring microscope should have adjustable illumination intensity, adjustable alignment, aperture, and field diaphragms.

6.4.4 Magnifications should be provided so that the diagonal can be enlarged to greater than 25 % but less than 75 % of the field width.

6.5 Verifications—All testers and indenters used to perform Knoop and Vickers hardness tests shall meet the requirements defined in **Annex A1** prior to performing hardness tests.

7. Test Specimen

7.1 There is no standard shape or size for a Knoop or Vickers test specimen. The specimen on which the indentation is made should conform to the following:

7.1.1 Preparation—For optimum accuracy of measurement, the test should be performed on a flat specimen with a polished or otherwise suitably prepared surface. The quality of the required surface finish can vary with the forces and magnifications used. The lower the test force and the smaller the indentation size, the more critical the surface preparation. Specimen preparation should be performed in accordance with applicable section of **Guide E3**. In all tests, the preparation should be such that the indentation perimeter and the indentation tips in particular, can be clearly defined when observed by the measuring system.

7.1.1.1 The test surface shall be free of any defects that could affect the indentation or the subsequent measurement of the diagonals. It is well known that improper grinding and polishing methods can alter test results either due to excessive

heating or cold work. Some materials are more sensitive to preparation-induced damage than others; therefore special precautions must be taken during specimen preparation. Specimen preparation must remove any damage introduced during these steps.

7.1.1.2 The specimen surface should not be etched before making an indentation. Etched surfaces can obscure the edge of the indentation, making an accurate measurement of the size of the indentation difficult. However, when determining the microindentation hardness of an isolated phase or constituent, a light etch can be used to delineate the object of interest.

7.1.2 Alignment—To obtain usable information from the test, the specimen should be prepared or mounted so that the test surface is perpendicular to the axis of the indenter. This can readily be accomplished by surface grinding (or otherwise machining) the opposite side of the specimen parallel with the side to be tested. Non-parallel samples can be tested using clamping and leveling fixtures designed to align the test surface properly to the indenter.

7.1.3 Mounted Samples—In many instances, it is necessary to mount the specimen for convenience in preparation and to maintain a sharp edge when surface gradient tests are to be performed on the sample. When mounting is required, the specimen must be adequately supported by the mounting medium so that the specimen does not move during force application, that is, avoid the use of polymeric mounting compounds that creep under the indenter force.

7.1.4 Thickness—the thickness of the specimen tested shall be such that no bulge or other marking showing the effect of the test force appears on the side of the piece opposite the indentation. The thickness of the material under test should be at least ten times the depth of the indentation. This is also to be used as a guideline for the minimum depth of a coating on a material.

7.1.5 Radius of Curvature—due caution should be used in interpreting or accepting the results of tests made on spherical or cylindrical surfaces. Results will be affected even in the case of the Knoop test where the radius of curvature is in the direction of the short diagonal. **Table 1** provides correction factors that shall be applied when performing Vickers test on spherical surfaces.

NOTE 8—A method for correcting Vickers hardness readings taken on spherical or cylindrical surfaces can be found in the International Organization for Standardization (ISO) Vickers Hardness Standard (**ISO 6507-1**).

8. Procedure

8.1 Test temperature—Knoop and Vickers hardness tests should be carried out at a temperature within the limits of 10 to 35°C (50 to 95°F). Because variations within this temperature range may affect results, users may choose to control temperature within a tighter range.

8.2 Indenter—Select the desired indenter, either Knoop or Vickers, to suit the desired test scale to be performed. Refer to the manufacturer's instruction manual for the proper procedure if it is necessary to change indenters.

TABLE 1 Correction Factors for Use in Vickers Hardness Tests Made on Spherical Surfaces

Convex Surface		Concave Surface	
d/D^A	Correction Factor	d/D^A	Correction Factor
0.004	0.995	0.004	1.005
0.009	0.990	0.008	1.010
0.013	0.985	0.012	1.015
0.018	0.980	0.016	1.020
0.023	0.975	0.020	1.025
0.028	0.970	0.024	1.030
0.033	0.965	0.028	1.035
0.038	0.960	0.031	1.040
0.043	0.955	0.035	1.045
0.049	0.950	0.038	1.050
0.055	0.945	0.041	1.055
0.061	0.940	0.045	1.060
0.067	0.935	0.048	1.065
0.073	0.930	0.051	1.070
0.079	0.925	0.054	1.075
0.086	0.920	0.057	1.080
0.093	0.915	0.060	1.085
0.100	0.910	0.063	1.090
0.107	0.905	0.066	1.095
0.114	0.900	0.069	1.100
0.122	0.895	0.071	1.105
0.130	0.890	0.074	1.110
0.139	0.885	0.077	1.115
0.147	0.880	0.079	1.200
0.156	0.875	0.082	1.125
0.165	0.870	0.084	1.130
0.175	0.865	0.087	1.135
0.185	0.860	0.089	1.140
0.195	0.855	0.091	1.145
0.206	0.850	0.094	1.150

^A D = diameter of sphere.
 d = mean diagonal of impression in millimeters.

8.2.1 After each change, or removal and replacement, of the indenter it is recommended that a daily verification be performed as defined in A1.5. At least two preliminary indentations should be made to ensure that the indenter is seated properly. The results of the preliminary indentations shall be disregarded.

8.2.2 Occasionally clean the indenter with a cotton swab and alcohol. Avoid creating static charges during cleaning. Indenting a piece of paper will often remove oil from the indenter

8.2.3 Indenters should be examined periodically and replaced if they become worn, dulled, chipped, cracked or separated from the mounting material. Checks of the indenter by the user may be performed by visual inspection of the resulting indentation; it is sufficient to verify the absence of defects from the shape of indentations performed on test blocks

8.3 *Magnitude of Test Force*—Select the desired test force on the tester by following the manufacturers instructions.

8.3.1 After each change of a test force, it is recommended that the operation of the machine be checked by performing a daily verification as defined in A1.5.

8.4 *Mount the specimen to the tester*—Mount the specimen on the tester stage or place it in the top-surface indexed mounting fixture on the stage so that the test surface is perpendicular to the indenter axis.

8.5 *Locate the test point*—Focus the measuring microscope with a low power objective so that the specimen surface can be observed. Adjust the light intensity and adjust the diaphragms for optimum resolution and contrast. Adjust the position of the sample so that the indent will be made in the desired location on the test surface. Before applying the force, make a final focus using the measuring objective or the highest magnification objective available.

8.6 *Force Application*—Apply the selected test force as follows without shock or vibration:

8.6.1 For micro test force range testing the indenter shall contact the specimen at a velocity between 15 and 70 $\mu\text{m/s}$. For macro test force ranges the contact velocity should not exceed 0.2 mm/s.

8.6.2 The time from the initial application of the force until the full test force is reached shall not be more than 10 s.

8.6.3 The full test force shall be applied for 10 to 15 s unless otherwise specified.

8.6.3.1 For some applications it may be necessary to apply the test force for longer times. In these instances the tolerance for the time of the applied force shall be ± 2 s. The application time shall be defined in the report

8.6.4 Remove the test force without shock or vibration.

8.7 *Test location*—After the force is removed, switch to the measuring mode, and select the proper objective lens. Focus the image, adjust the light intensity if necessary, and adjust the diaphragms for maximum resolution and contrast.

8.7.1 Examine the indentation for its position relative to the desired location and for its symmetry.

8.7.2 If the indentation did not occur at the desired spot, the tester is out of alignment. Consult the manufacturer's instruction manual for the proper procedure to produce alignment. Make another indentation and recheck the indentation location. Readjust and repeat as necessary.

8.8 *Indentation examination:*

8.8.1 For a Knoop indentation, if one half of the long diagonal is greater than 10 % longer than the other, or if both ends of the indentation are not in sharp focus, the test specimen surface may not be perpendicular to the indenter axis. Check the specimen alignment and make another test. Indents that exceed the 10% limit should be noted in the test report.

8.8.2 For a Vickers indentation, if one half of either diagonal is more than 5 % longer than the other half of that diagonal, or if the four corners of the indentation are not in sharp focus, the test surface may not be perpendicular to the indenter axis. Check the specimen alignment and make another test. Indents that exceed the 5% limit should be noted in the test report.

8.8.3 If the diagonal legs are unequal as described in 8.8.1 or 8.8.2 rotate the specimen 90° and make another indentation in an untested region. If the nonsymmetrical aspect of the indentations has rotated 90°, then the specimen surface is not perpendicular to the indenter axis. If the nonsymmetrical nature of the indentation remains in the same orientation, check the indenter for misalignment or damage.

8.8.4 Some materials may have nonsymmetrical indentations even if the indenter and the specimen surface are perfectly aligned. Tests on single crystals or on textured materials may produce such results. When this occurs, check the alignment using a test specimen, such as a standardized test block, known to produce uniformly shaped indentations. Testers that do not perform symmetrical indents on those specimens shall not be used until they meet the requirements of sections 8.8.1 and 8.8.2.

8.8.5 Brittle materials such as ceramics may crack as a result of being indented. Specific details for testing ceramics are contained in Test Methods C1326 and C1327.

8.9 Indent Measurement:

8.9.1 Measure the long diagonal of a Knoop indentation, and both diagonals of a Vickers indentation, by operating the measuring device in accordance with the manufacturer’s instruction manual.

8.9.2 Determine the length of the diagonals to 0.5 μm or less (see 6.4).

8.9.3 For the Vickers indentations, average the two diagonal length measurements.

8.10 Knoop or Vickers hardness calculation:

8.10.1 Compute the Knoop or Vickers hardness number using the appropriate equation in 5.5 or 5.6 or Table X6.1 or Table X6.2, respectively. Table X6.1 and Table X6.2 show the Knoop or Vickers hardness for indentations with diagonal lengths from 1 to 200.9 μm using 1 gf. If the force was not 1 gf, multiply the value from Table X6.1 or Table X6.2 by the actual gram-force value to obtain the correct hardness number.

8.11 Spacing of Indentations—Generally more than one indentation is made on a test specimen. It is necessary to ensure

that the spacing between indentations is large enough so that adjacent tests do not interfere with each other.

8.11.1 For most testing purposes, the minimum recommended spacing between separate tests, and minimum distance between an indentation and the edge of the specimen are illustrated in Fig. 3.

8.11.2 For some applications, closer spacing of indentations than those shown in Fig. 3 may be desired. If closer indentation spacing is used, it shall be the responsibility of the testing laboratory to verify the accuracy of the testing procedure.

9. Report

9.1 Report the following information:

9.1.1 The test results (see 5.8), the number of tests, and, where appropriate, the mean and standard deviation of the results,

9.1.2 Test force,

9.1.3 The total force application time if outside the limits of 10 to 15 s as defined in 8.6.3.

9.1.4 Any unusual conditions encountered during the test, and

9.1.5 The test temperature, when the outside the recommended allowable range of 10°C to 35°C (50°F to 95°F).

10. Precision and Bias

10.1 The precision and bias of Knoop and Vickers hardness measurements depend on strict adherence to the stated test procedure and are influenced by instrumental and material factors and indentation measurement errors.

10.2 The consistency of agreement for repeated tests on the same material is dependent on the homogeneity of the material,

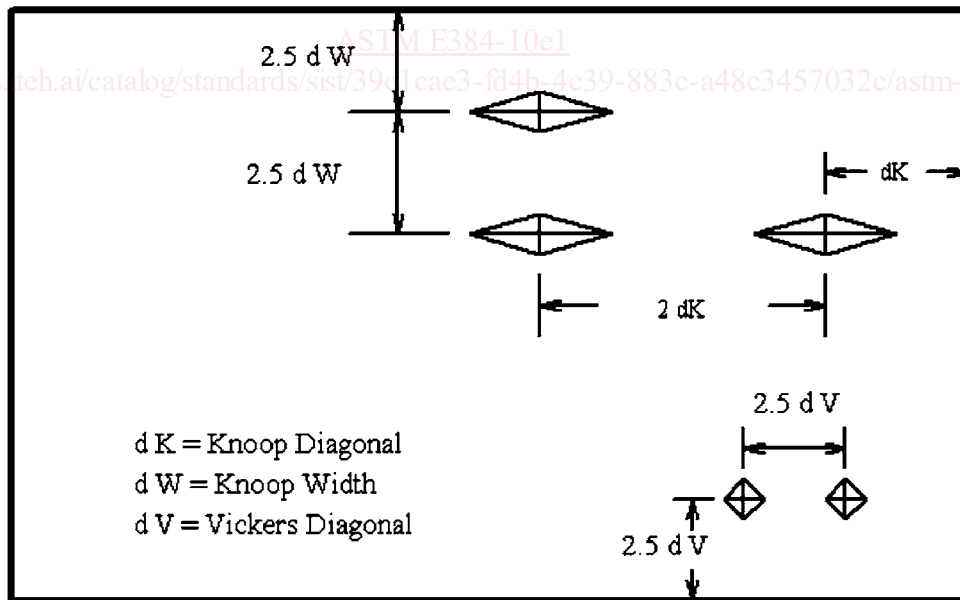

FIG. 3 Minimum Recommended Spacing for Knoop and Vickers Indentations

reproducibility of the hardness tester, and consistent, careful measurement of the indents by a competent operator.

10.3 Instrumental factors that can affect test results include: accuracy of loading; inertia effects; speed of loading; vibrations; the angle of indentation; lateral movement of the indenter or specimen; indentation and indenter shape deviations.

10.3.1 Vibrations during indenting will produce larger indentations with the influence of vibrations becoming larger as the force decreases (1, 2).⁴

10.3.2 The angle between the indenter and specimen surface should be within 2° of perpendicular. Greater amounts of tilting produce nonuniform indentations and invalid test results.

10.4 Material factors that can affect test results include: specimen homogeneity, orientation or texture effects; improper specimen preparation; low specimen surface reflectivity; transparency of the specimen.

10.4.1 Residual deformation from mechanical polishing must be removed, particularly for low-force testing.

10.4.2 Distortion of the indentation shape due to either crystallographic or microstructural texture influences diagonal lengths and the validity of the calculated hardness.

10.4.3 Plastic deformation during indenting can produce ridging around the indentation periphery that will affect diagonal measurement accuracy.

10.4.4 Testing of etched surfaces, depending on the extent of etching, can produce results that are different from those obtained on unetched surfaces (1).

10.5 Measurement errors that can affect test results include: inaccurate calibration of the measuring device; inadequate resolving power of the objective; insufficient magnification; operator bias in sizing the indentations; poor image quality; nonuniform illumination, improper zeroing of the measuring device.

10.5.1 The accuracy of Knoop and Vickers hardness testing is strongly influenced by the accuracy to which the indentations can be measured.

10.5.2 The error in measuring the diagonals increases as the numerical aperture of the measuring objective decreases (3, 4).

10.5.3 Bias is introduced if the operator consistently undersizes or oversizes the indentations.

10.6 Some of the factors that affect test results produce systematic errors that influence all test results while others primarily influence low-force test results (5). Some of these problems occur continually, others may occur in an undefined, sporadic manner. Low force hardness tests are influenced by these factors to a greater extent than high force tests.

10.7 For both the Vickers and Knoop hardness tests, the calculated hardness is a function of three variables: force, indenter geometry and diagonal measurement. Total differentials of the equations used to calculate the hardness can be used to evaluate the effect variations in these parameters can cause.

10.7.1 *Vickers*—using Eq 6, the total differential for the Vickers hardness number is:

$$dV = \left(\frac{\partial V}{\partial P}\right) dP + \left(\frac{\partial V}{\partial d}\right) dd + \left(\frac{\partial V}{\partial \alpha}\right) d\alpha \quad (10)$$

and

$$\left(\frac{\partial V}{\partial P}\right) = 2 \times 10^3 \times d^2 \times \sin\left(\frac{\alpha}{2}\right) \quad (11)$$

$$\left(\frac{\partial V}{\partial d}\right) = -4 \times 10^3 \times P \times d^{-3} \sin\left(\frac{\alpha}{2}\right) \quad (12)$$

$$\left(\frac{\partial V}{\partial \alpha}\right) = 10^3 \times P \times d^{-2} \cos\left(\frac{\alpha}{2}\right) \quad (13)$$

For a material having a hardness of 500 HV when tested with a 500 gf force, $d = 43.06 \mu\text{m}$, $\alpha = 136^\circ$, and

$$\sin\left(\frac{\alpha}{2}\right) = 0.927184.$$

10.7.1.1 Consider introducing a 1 % error into the hardness of the material through an error in either the applied force, the indenter constant or the measured diagonal length. In this case, the hardness would be $HV' = 505$ or $dV = 5$. Using Eq 11-13, the corresponding errors in the various parameters are as shown in Table 2. Thus a 1 % change in P or a 2.836 % error in α creates a 1 % error in the Vickers hardness number. However, only a 0.5 % error in the measured diagonal is needed to create a 1 % error in Vickers hardness. Furthermore, this analysis indicates that the calculated Vickers hardness number is not strongly influenced by errors in the angle of the indenter.

10.7.2 *Knoop*—Similarly, using Eq 1, it follows that:

$$dK = \left(\frac{\partial K}{\partial P}\right) dP + \left(\frac{\partial K}{\partial c_p}\right) dc_p + \left(\frac{\partial K}{\partial d}\right) dd \quad (14)$$

$$\frac{10^3}{c_p d^2} dP + \frac{10^3 P}{c_p^2 d^2} dc_p + \frac{-2 \times 10^3 P}{c_p d^3} dd \quad (15)$$

and since the indenter has two different angles, A and B,

$$dc_p = \left(\frac{\partial c_p}{\partial A}\right) dA + \left(\frac{\partial c_p}{\partial B}\right) dB \quad (16)$$

$$\left(\frac{\partial c_p}{\partial \angle A}\right) = \frac{-\tan\left(\frac{\angle B}{2}\right)}{4 \sin^2\left(\frac{\angle A}{2}\right)} \quad (17)$$

and

$$\left(\frac{\partial c_p}{\partial \angle B}\right) = \frac{\cot\left(\frac{\angle A}{2}\right)}{4 \cos^2\left(\frac{\angle B}{2}\right)} \quad (18)$$

TABLE 2 Vickers Hardness Analysis—1 % Error

Force, gf	Diagonal, μm	1 % Error		
		ΔP , gm	Δ Diagonal, μm	Δ Angle, °
10	6.090	0.100	-0.030	2.836
20	8.612	0.200	-0.043	2.836
50	13.617	0.499	-0.068	2.836
100	19.258	0.999	-0.096	2.836
200	27.235	1.998	-0.136	2.836
500	43.062	4.994	-0.215	2.836
1000	60.899	9.988	-0.304	2.836

⁴ The boldface numbers in parentheses refer to the list of references at the end of this standard.

10.7.2.1 Using the differentials cited in 10.7.2, for the Knoop test at various forces, for a 1 % error in hardness that is, $HK = 505$ or $dK = 5$, the corresponding errors in the force, diagonal measurement and indenter angle are as shown in Table 3. From this analysis it follows that 1 % error in P creates a 1 % error in HK , 0.5 % error in the measured diagonal creates a 1 % error in HK , and 1 % error in c creates a 1 % error in HK .

10.7.2.2 Since the indenter constant is composed of terms from two different angles, either a 4' 3" error in $\angle A$, or a 26' 20" error in $\angle B$ produces a 1 % error in HK . Unlike the Vickers indenter, the calculated Knoop hardness number is very strongly influenced by small errors in the two angles of the indenter. The A angle, $172^\circ 30' 00''$, is the most sensitive of these parameters. The actual value of c_p for each indenter can be calculated using the certified A and B angles provided by the indenter manufacturer. This will enhance the accuracy of the test measurements.

10.8 Over a period of several years, four separate interlaboratory studies have been conducted in accordance with Practice E691 to determine the precision, repeatability, and reproducibility of this test method. The four studies are defined as follows:

- a) Knoop and Vickers tests, six test forces in the micro range, twelve laboratories, manual measurements, seven different hardness level samples. See 10.8.1 and Appendix X3.
- b) Knoop and Vickers tests, two test forces in the micro range, seven laboratories, Image Analysis and manual measurements, four different hardness level samples. See 10.8.2 and Appendix X4.
- c) Knoop and Vickers tests, six test forces in the micro range, twenty-five laboratories, manual measurements, six different hardness level samples. See 10.8.3.
- d) Vickers tests, four test forces in the macro range, seven laboratories, manual measurements, three different hardness level samples. See 10.8.4.

10.8.1 An interlaboratory test program was conducted in accordance with Practice E691 to develop information regarding the precision, repeatability, and reproducibility of the measurement of Knoop and Vickers indentations in the micro ranges⁵. The test forces were 25, 50, 100, 200, 500, and 1000 gf on three ferrous and four nonferrous specimens (6,7). Twelve laboratories measured the indentations, five of each

type at each force on each sample. Additional details of this study are given in Appendix X3.

10.8.1.1 Tests of the three ferrous specimens revealed that nine laboratories produced similar measurements while two laboratories consistently undersized the indentations and one laboratory consistently oversized the indentations. These latter results were most pronounced as the force decreased and specimen hardness increased (that is, as the diagonal size decreased) and were observed for both Vickers and Knoop indentations. Results for the lower hardness nonferrous indentations produced better agreement. However, none of the laboratories that obtained higher or lower results on the ferrous specimens measured the nonferrous indentations.

10.8.1.2 *Repeatability Interval*—The difference due to test error between two test results in the same laboratory on the same material increases with increasing specimen hardness and with decreasing test force (see X3.4.4).

10.8.1.3 *Reproducibility Interval*—The difference in test results on the same material tested in different laboratories increased with increasing specimen hardness and with decreasing test force (see X3.4.5).

10.8.1.4 The within-laboratory and between-laboratory precision values improved as specimen hardness decreased and test force increased. The repeatability interval and reproducibility interval were generally larger than the precision estimate, particularly at low test forces and high specimen hardnesses.

10.8.2 *Image Analysis Measurements*—An interlaboratory test program was conducted in accordance with Practice E691 to develop information regarding the repeatability and reproducibility of Knoop and Vickers measurements made with automated Image Analysis systems and manual procedures. Four ferrous specimens were used in the round robin. The test were conducted at 100 gf and 300 gf. The participants in the test program measured the same indentations on the four specimens. Seven labs measured the specimens using both procedures. The Knoop indentations on specimen C1 were too long for accurate measurements to be made by one lab; hence, only six sets of measurements were made on this specimen. Near the end of the test program, specimen B1 was lost in shipping; thus only six sets of measurements were made on this specimen. Additional details of the study are contained in Appendix X4.

10.8.2.1 Repeatability concerns the variability between individual test results obtained within a single laboratory by a single operator with a specific set of test apparatus. For both the manual and automated measurements, the repeatability interval increased with specimen hardness and decreasing test force, Appendix X4. For equivalent testing conditions, the repeatability interval for automated measurements was slightly larger than for manual measurements.

10.8.2.2 Reproducibility deals with the variability between single test results obtained by different laboratories applying the same test methods to the same or similar test specimens. For both the manual and automated measurements, the reproducibility interval increased with specimen hardness and decreasing test force, Appendix X4. For equivalent testing

⁵ Supporting data have been filed at ASTM International Headquarters and may be obtained by requesting Research Report RR:E04-1004.

TABLE 3 Knoop Hardness Analysis—1 % Error

Force, gm	Diagonal, μm	1 % Error			
		ΔP gm	Δ diagonal, μm	ΔA , $^\circ$	ΔB , $^\circ$
10	16.87	0.10	-0.08	0.075	0.439
20	23.86	0.20	-0.12	0.075	0.439
50	37.72	0.50	-0.19	0.075	0.439
100	53.35	1.00	-0.27	0.075	0.439
200	75.45	2.00	-0.38	0.075	0.439
500	119.29	5.00	-0.60	0.075	0.439
1000	168.71	10.00	-0.84	0.075	0.439
				4' 30"	26' 20"

conditions, the reproducibility interval for automated measurements was slightly larger than for manual measurements.

10.8.2.3 Practice E691 nor any other ASTM standard deals with comparing test results of a single property made by two different test methods. Hence it is not possible to statistically and accurately compare the hardness measurements made by the manual and automated procedures. However, this information is graphically represented for comparative purposes, X4.6.

10.8.3 The precision of this test method is based on an interlaboratory study of E384-07, Standard Test Method for Microindentation Hardness of Materials, conducted in 2007. Twenty-five laboratories tested a total of six ferrous materials for Vickers Hardness and thirteen laboratories submitted Knoop Hardness results. Every “test result” was recorded, and the laboratory means represent an average of five individual determinations (for Knoop) or five separate measurements, each the average of two readings (for Vickers). Practice E691

was followed for the design and analysis of the data; the details are given in ASTM Research Report No. E04-1006.⁶

10.8.3.1 *Repeatability limit (r)*—Two test results obtained within one laboratory shall be judged not equivalent if they differ by more than the “r” value for that material; “r” is the interval representing the critical difference between two test results for the same material, obtained by the same operator using the same equipment on the same day in the same laboratory.

10.8.3.2 Repeatability limits are listed in Table 4 and Table 5 and Fig. 4 and Fig. 5 and in hardness units (HK, HV) in Table 6 and Table 7 and Fig. 6 and Fig. 7.

10.8.3.3 *Reproducibility limit (R)*—Two test results shall be judged not equivalent if they differ by more than the “R” value for that material; “R” is the interval representing the critical difference between two test results for the same material, obtained by different operators using different equipment in different laboratories.

⁶ Supporting data have been filed at ASTM International Headquarters and may be obtained by requesting Research Report RR:E04-1006.

TABLE 4 Precision Statistics for an Interlaboratory Study of the Knoop Microindentation Hardness Test for Ferrous Specimens in Diagonal Units (μm)

Specimen	Test Force (gf)	Average Diagonal (μm)	Standard Deviation (μm)	Repeatability Standard Deviation (μm)	Reproducibility Standard Deviation (μm)	Repeatability Limit (μm)	Reproducibility Limit (μm)
		\bar{d}	S_x	S_r	S_R	r	R
A	25	35.61	1.40	0.72	1.54	2.00	4.31
	50	51.77	1.33	1.11	1.66	3.12	4.66
	100	74.84	1.65	1.77	2.28	4.95	6.40
	300	132.28	2.63	2.57	3.50	7.20	9.79
	500	171.51	2.07	2.46	3.02	6.89	8.45
	1000	243.11	1.72	2.96	3.16	8.29	8.84
B	25	23.66	0.95	0.48	1.04	1.34	2.91
	50	34.33	0.94	0.56	1.07	1.57	2.99
	100	49.61	1.12	0.65	1.26	1.82	3.54
	300	88.64	1.39	0.88	1.59	2.45	4.46
	500	115.48	1.68	1.11	1.95	3.11	5.46
	1000	164.38	1.65	1.52	2.14	4.25	5.98
C	25	27.62	1.33	0.49	1.41	1.38	3.93
	50	39.47	1.14	0.50	1.22	1.39	3.43
	100	56.66	1.05	0.64	1.20	1.79	3.35
	300	100.14	1.25	0.81	1.44	2.26	4.03
	500	130.19	1.50	0.83	1.68	2.33	4.69
	1000	184.84	1.79	1.19	2.08	3.33	5.82
D	25	31.04	1.04	0.46	1.11	1.28	3.12
	50	44.64	0.85	0.46	0.95	1.30	2.65
	100	64.22	1.08	0.67	1.24	1.89	3.47
	300	113.94	0.94	0.82	1.19	2.29	3.33
	500	148.16	1.16	0.74	1.33	2.06	3.73
	1000	210.10	2.03	1.64	2.50	4.58	7.00
E	25	20.02	0.72	0.48	0.84	1.36	2.34
	50	29.03	1.00	0.48	1.09	1.34	3.05
	100	42.21	1.15	0.52	1.24	1.46	3.46
	300	76.03	1.00	0.53	1.11	1.48	3.10
	500	99.25	1.06	0.49	1.15	1.37	3.21
	1000	141.67	1.27	0.85	1.48	2.39	4.15
T	25	17.14	0.88	0.48	0.98	1.35	2.76
	50	25.59	1.03	0.47	1.12	1.32	3.12
	100	37.20	1.45	0.52	1.52	1.46	4.26
	300	67.43	1.39	0.65	1.51	1.82	4.22
	500	88.27	1.11	0.66	1.26	1.85	3.53
	1000	126.96	1.47	0.75	1.61	2.09	4.52

TABLE 5 Precision statistics for an Interlaboratory Study of the Vickers Microindentation Hardness Test for Ferrous Specimens in Diagonal Units (μm)

Specimen	Test Force (gf)	Average Diagonal (μm)	Standard Deviation (μm)	Repeatability Standard Deviation (μm)	Reproducibility Standard Deviation (μm)	Repeatability Limit (μm)	Reproducibility Limit (μm)
		\bar{d}	S_x	S_r	S_R	r	R
A	25	13.89	0.75	0.30	0.80	0.85	2.24
	50	19.81	0.61	0.34	0.68	0.95	1.91
	100	28.10	0.57	0.45	0.70	1.26	1.96
	300	49.19	0.75	0.72	0.99	2.02	2.77
	500	63.65	0.81	0.88	3.16	2.47	1.13
	1000	90.48	0.98	1.31	1.53	3.66	4.28
B	25	9.35	0.40	0.25	0.46	0.69	1.28
	50	13.06	0.37	0.23	0.42	0.63	1.18
	100	18.51	0.39	0.39	0.52	1.09	1.47
	300	32.11	0.43	0.30	0.50	0.84	1.41
	500	41.68	0.51	0.36	0.60	1.00	1.69
	1000	59.21	0.55	0.52	0.72	1.46	2.03
C	25	10.81	0.53	0.19	0.56	0.54	1.56
	50	15.13	0.42	0.20	0.46	0.57	1.29
	100	21.34	0.40	0.22	0.45	0.62	1.25
	300	36.85	0.38	0.21	0.43	0.59	1.20
	500	47.68	0.55	0.24	0.59	0.67	1.64
	1000	67.60	0.58	0.33	0.65	0.93	1.83
D	100	24.50	0.43	0.29	0.50	0.82	1.40
	300	42.52	0.41	0.28	0.48	0.80	1.35
	500	55.02	0.50	0.25	0.55	0.70	1.54
	1000	78.14	0.70	0.34	0.77	0.97	2.15
E	100	15.61	0.40	0.18	0.43	0.52	1.20
	300	27.25	0.41	0.25	0.46	0.70	1.30
	500	35.26	0.43	0.20	0.46	0.55	1.30
	1000	50.06	0.41	0.24	0.46	0.67	1.29
T	300	23.94	0.47	0.17	0.49	0.49	1.38
	500	31.00	0.51	0.21	0.55	0.59	1.53
	1000	44.12	0.50	0.25	0.55	0.69	1.53

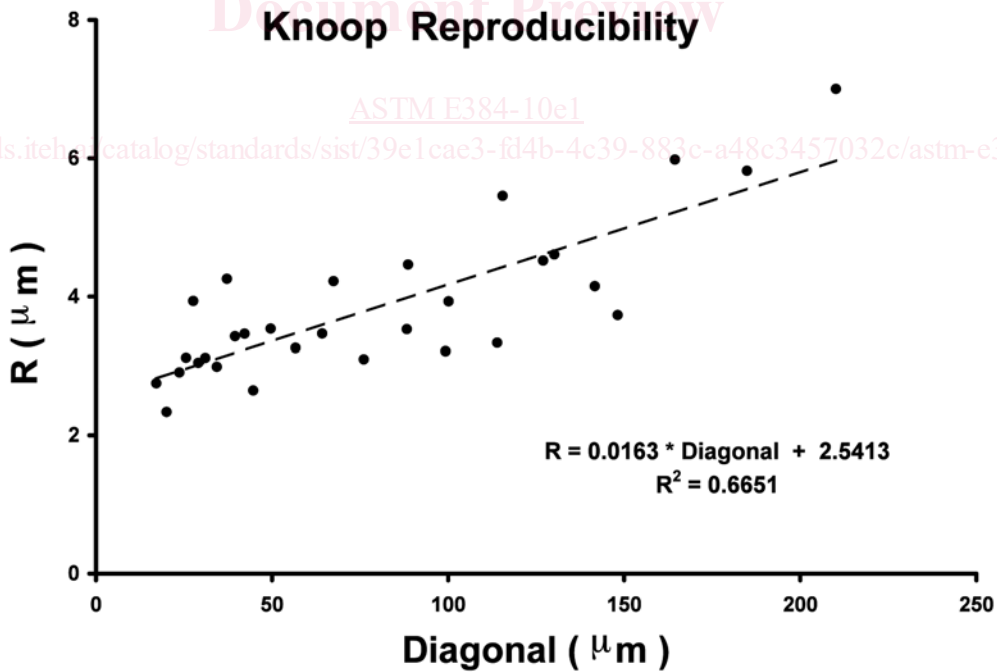

FIG. 4 The Relationship between Reproducibility (R) and Diagonal length (d) from Table 5 in μm units, for the Knoop Hardness Tests for Specimens B, C, D, E and T

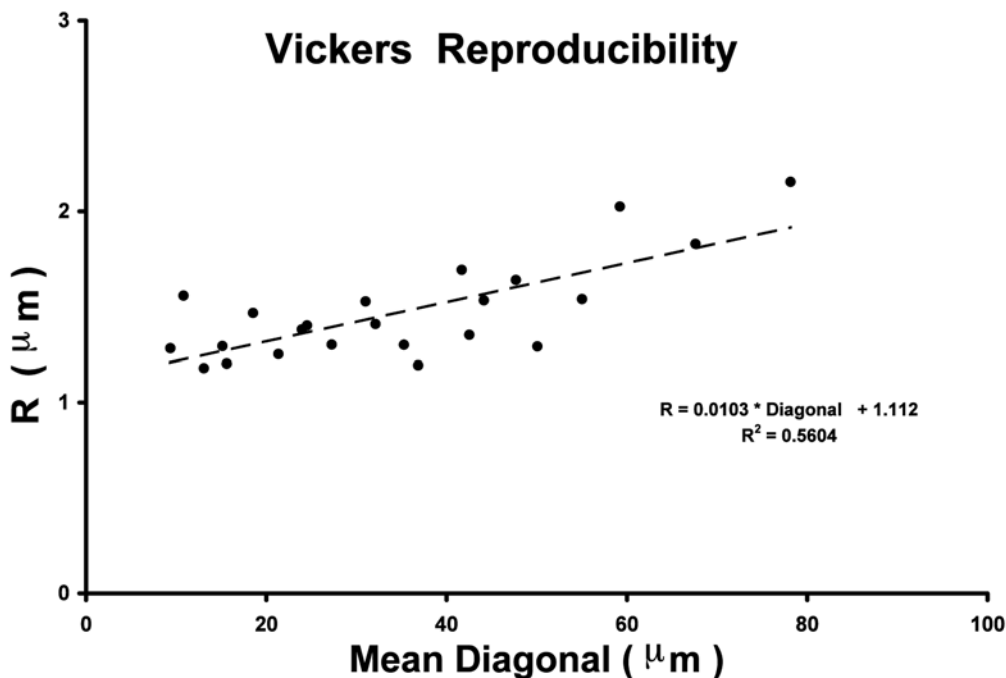

FIG. 5 The Relationship between Reproducibility and Diagonal length (d) from Table 6 in μm units, for the Vickers Hardness Tests for Specimens B, C, D, E and T

10.8.3.4 Reproducibility limits in diagonal lengths (μm) are listed in Table 4 and Table 5 and Fig. 4 and Fig. 5 in hardness units (HK, HV) in Table 6 and Table 7 and Fig. 6 and Fig. 7.

10.8.3.5 The above terms (repeatability limit and reproducibility limit) are used as specified in Practice E177.

10.8.3.6 Any judgment in accordance with statements 10.8.3.1 and 10.8.3.3 would have an approximate 95% probability of being correct.

10.8.3.7 The precision statement was determined through statistical examination of results from twenty-five laboratories, on six ferrous materials. These six ferrous materials were described as:

Specimen A: H13, mill annealed, hardness less than 20 HRC
 Specimen B: H13, austenitized, quenched, and tempered ~ 50 HRC

Specimen C: H13, austenitized, quenched, and tempered ~ 40 HRC

Specimen D: H13, austenitized, quenched, and tempered ~ 30 HRC

Specimen E: O1, austenitized, quenched and tempered O1 steel, ~ 60 HRC

Specimen T: T15 P/M, austenitized, quenched and tempered ~ 67 HRC

To judge the equivalency of two test results, it is recommended to choose the material closest in characteristics to the test material.

10.8.4 The macro Vickers precision statement is based on an interlaboratory study of E92, Standard Test Method for Vickers Hardness of Metallic Materials, conducted in 2001. (With this revision Test Method E92 is now part of E384) Seven laboratories tested three different standard hardness test blocks using macro range test forces of 1kg, 5kg, 10kg, and 20kg.

Only four laboratories were also able to provide results at 50kg test force. Every “test result” represents an individual determination of the Vickers hardness of the material. Each laboratory was asked to report triplicate test results in order to permit the estimation of Intralaboratory precision. Practice E691 was followed for the design and analysis of the data; the details are given in ASTM Research Report No. RR:E04-1007⁷.

10.8.4.1 *Repeatability limit (r)*—Two test results obtained within one laboratory shall be judged not equivalent if they differ by more than the “ r ” value for that material; “ r ” is the interval representing the critical difference between two test results for the same material, obtained by the same operator using the same equipment on the same day in the same laboratory. Repeatability limits are listed in Tables 8-12 below.

10.8.4.2 *Reproducibility limit (R)*—Two test results shall be judged not equivalent if they differ by more than the “ R ” value for that material; “ R ” is the interval representing the critical difference between two test results for the same material, obtained by different operators using different equipment in different laboratories. Reproducibility limits are listed Tables 8-12 in below.

10.8.4.3 The above terms (repeatability limit and reproducibility limit) are used as specified in Practice E92.

10.8.4.4 Any judgment in accordance with statements 10.8.4.1 and 10.8.4.2 would have an approximate 95% probability of being correct.

10.8.4.5 *Bias*—There is no recognized standard by which to estimate the bias of this test method

⁷ Supporting data have been filed at ASTM International Headquarters and may be obtained by requesting Research Report RR: RR:E04-1007.