



Standard Specification for Polyethylene/Aluminum/Polyethylene (PE-AL-PE) Composite Pressure Pipe¹

This standard is issued under the fixed designation F1282; the number immediately following the designation indicates the year of original adoption or, in the case of revision, the year of last revision. A number in parentheses indicates the year of last reapproval. A superscript epsilon (ϵ) indicates an editorial change since the last revision or reapproval.

1. Scope*

1.1 This specification covers a coextruded polyethylene composite pressure pipe with a welded aluminum tube reinforcement between the inner and outer layers. The inner and outer polyethylene layers are bonded to the aluminum tube by a melt adhesive. Included is a system of nomenclature for the polyethylene-aluminum-polyethylene (PE-AL-PE) pipes, the requirements and test methods for materials, the dimensions and strengths of the component tubes and finished pipe, adhesion tests, and the burst and sustained pressure performance. Also given are the requirements and methods of marking. The pipe covered by this specification is intended for use in potable water distribution systems for residential and commercial applications, water service, underground irrigation systems, and radiant panel heating systems, baseboard, snow- and ice-melt systems, and gases that are compatible with composite pipe and fittings.

1.2 This specification relates only to metal and plastic composite pipes incorporating a welded metallic tube. The welded metallic tube of itself is capable of sustaining internal pressures. Pipes consisting of metallic layers not welded together are outside the scope of this specification.

1.3 Specifications for connectors for use with pipe meeting the requirements of this specification are given in **Annex A1**.

1.4 This specification excludes crosslinked polyethylene-aluminum-crosslinked polyethylene pipes (see Specification **F1281**).

1.5 The values stated in SI units are to be regarded as the standard. The values given in parentheses are for information only.

1.6 The following precautionary caveat pertains only to the test methods portion, Section 9, of this specification: *This standard does not purport to address all of the safety concerns, if any, associated with its use. It is the responsibility of the user*

of this standard to establish appropriate safety and health practices and determine the applicability of regulatory limitations prior to use.

2. Referenced Documents

2.1 ASTM Standards:²

- D618 Practice for Conditioning Plastics for Testing
- D1598 Test Method for Time-to-Failure of Plastic Pipe Under Constant Internal Pressure
- D1599 Test Method for Resistance to Short-Time Hydraulic Pressure of Plastic Pipe, Tubing, and Fittings
- D1600 Terminology for Abbreviated Terms Relating to Plastics
- D1898 Practice for Sampling of Plastics (Withdrawn 1998)³
- D2104 Specification for Polyethylene (PE) Plastic Pipe, Schedule 40 (Withdrawn 2010)³
- D2122 Test Method for Determining Dimensions of Thermoplastic Pipe and Fittings
- D2837 Test Method for Obtaining Hydrostatic Design Basis for Thermoplastic Pipe Materials or Pressure Design Basis for Thermoplastic Pipe Products
- D3035 Specification for Polyethylene (PE) Plastic Pipe (DR-PR) Based on Controlled Outside Diameter
- D3350 Specification for Polyethylene Plastics Pipe and Fittings Materials
- E8 Test Methods for Tension Testing of Metallic Materials
- F412 Terminology Relating to Plastic Piping Systems
- F1281 Specification for Crosslinked Polyethylene/Aluminum/Crosslinked Polyethylene (PEX-AL-PEX) Pressure Pipe
- F1974 Specification for Metal Insert Fittings for Polyethylene/Aluminum/Polyethylene and Crosslinked Polyethylene/Aluminum/Crosslinked Polyethylene Composite Pressure Pipe

¹ This specification is under the jurisdiction of ASTM Committee F17 on Plastic Piping Systems and is the direct responsibility of Subcommittee F17.11 on Composite.

Current edition approved Feb. 15, 2010. Published March 2010. Originally approved in 1990. Last previous edition approved in 2006 as F1282 – 06. DOI: 10.1520/F1282-10.

² For referenced ASTM standards, visit the ASTM website, www.astm.org, or contact ASTM Customer Service at service@astm.org. For *Annual Book of ASTM Standards* volume information, refer to the standard's Document Summary page on the ASTM website.

³ The last approved version of this historical standard is referenced on www.astm.org.

*A Summary of Changes section appears at the end of this standard

TABLE 1 Outside Diameters, Aluminum Thickness, and Tolerances for PE-AL-PE

| Nominal Pipe Size, mm (in.) | Minimum Outside Diameter, mm (in.) | Tolerance on Minimum, mm (in.) | Maximum Out-of-Roundness, ^A mm (in.) | Minimum Aluminum Thickness, mm (in.) | Tolerance on Thickness, mm (in.) |
|-----------------------------|------------------------------------|--------------------------------|---|--------------------------------------|----------------------------------|
| 0912 (¾) | 12.00 (0.472) | +0.30 (0.012) | 0.3 (0.012) | 0.18 (0.007) | +0.09 (+0.0035) |
| 1216 (½) | 16.00 (0.630) | +0.30 (0.012) | 0.4 (0.016) | 0.18 (0.007) | +0.09 (+0.0035) |
| 1620 (¾) | 20.00 (0.787) | +0.30 (0.012) | 0.5 (0.020) | 0.23 (0.009) | +0.09 (+0.0035) |
| 2025 (¾) | 25.00 (0.984) | +0.30 (0.012) | 0.5 (0.020) | 0.23 (0.009) | +0.09 (+0.0035) |
| 2532 (1) | 32.00 (1.260) | +0.30 (0.012) | 0.5 (0.020) | 0.28 (0.011) | +0.09 (+0.0035) |
| 3240 (1¼) | 40.10 (1.579) | +0.30 (0.012) | 0.5 (0.020) | 0.33 (0.014) | |
| 4150 (1½) | 50.10 (1.972) | +0.30 (0.012) | 0.5 (0.020) | 0.47 (0.020) | |
| 5163 (2) | 63.10 (2.484) | +0.40 (0.016) | 0.5 (0.020) | 0.57 (0.024) | |
| 6075 (2½) | 75.10 (2.957) | +0.60 (0.024) | 1.0 (0.039) | 0.67 (0.028) | |

^A The out-of-roundness specification applies only to tubing prior to coiling.

2.2 NSF Standard:

Standard No. 14 [Plastics Piping System Components and Related Materials](#)⁴

Standard No. 61 [Drinking Water System Components—Health Effects](#)⁴

2.3 Uniform Classification Committee Standard:

Uniform Freight Classification⁵

2.4 National Motor Freight Association Standard:

National Motor Freight Classification⁶

2.5 Federal Standard:

Fed. Std. No. 123 [Marking for Shipments \(Civil Agencies\)](#)⁷

2.6 Military Standard:

MIL-STD-129 [Marking for Shipment and Storage](#)⁷

3. Terminology

3.1 *Definitions*—Definitions are in accordance with Terminology **F412**, and abbreviations are in accordance with Terminology **D1600**, unless otherwise specified.

3.2 Definitions of Terms Specific to This Standard:

3.2.1 *assembly*—the joint between a fitting and a length of pipe.

3.2.2 *pipe*—the complete structure, consisting of the aluminum, melt adhesive, and polyethylene layers intimately bonded together. The pipe for this specification is termed a PE-AL-PE composite pipe.

3.2.3 *pipe hoop stress*—for simplicity the value of the hoop stress quoted assumes a homogeneous wall. Local values of stress will vary with the different layers (see 3.2.3.1).

3.2.3.1 *Discussion*—Thick walled plastic pipes produced from one material have hoop stresses that vary through the wall, and are usually described by the Lamé Theory. The composite nature of the PE-AL-PE pipe, composed of materials with very different Young's Modulus values, will, on pressurization, not have a uniform stress distribution through the thickness of the wall of the pipe. The PE-AL-PE pipes have

⁴ Available from the NSF International, N. 789 Dixboro Rd., Ann Arbor, MI 48113-0140.

⁵ Available from the Uniform Classification Committee, Suite 1106, 222 South Riverside Plaza, Chicago, IL 60606.

⁶ Available from the National Motor Freight Traffic Association, Inc., National Motor Freight Classification, American Tracking Associations, Inc., Traffic Dept., 1616 P St., NW, Washington, DC 20036.

⁷ Available from Standardization Documents Order Desk, Bldg. 4 Section D, 700 Robbins Ave., Philadelphia, PA 19111-5098, Attn: NPODS.

a hoop stress distribution that differs substantially from both the thick and thin walled pipe cases.

4. Pipe Classification

4.1 *Pipe Diameter*—The PE-AL-PE composite pipes are classified by outside diameter.

4.2 *Pipe Dimension Ratio*—The concept of dimension ratio is not relevant to PE-AL-PE laminated pipes, and cannot be used to relate pressure rating with total wall thickness.

5. Materials

5.1 *General*—The PE-AL-PE pipe is composed of one metallic layer, two layers of the same polymeric adhesive and two layers of the same polyethylene. For pipe made to this specification the constituent materials must meet the following requirements:

5.2 *Aluminum*—The aluminum shall have a thickness as specified in **Table 1**. The material shall have minimum elongations and ultimate tensile strengths of 20 % and 100 MPa (14 600 psi), respectively. The tests shall be conducted according to Test Methods **E8**.

5.3 Polyethylene:

5.3.1 Polyethylene plastics used to make pipe meeting the requirements of this specification are categorized by means of two criteria, namely, (1) short-term strength tests and (2) long-term strength tests.

5.3.2 This specification covers pipe made from PE plastics as defined by three hydrostatic design stresses developed on the basis of long-term tests (see **Appendix X1**).

5.3.3 Polyethylene plastics used to make pipe meeting the requirements of this specification shall be virgin resin meeting the requirements of either Grade PE20, PE26, PE27, PE30, PE36, PE37, PE40, PE46 or PE47 and meeting the color and UV stabilizer code of either A, B, or C in accordance with Specification **D3350**.

5.3.3.1 Class B compounds shall have sufficient ultraviolet (UV) stabilizers to protect the pipe from deleterious effects due to continuous outdoor exposure during storage and shipping. Pipe produced from Class B compounds is not suitable for exposed outdoor application. Class A, B, and C compounds shall have sufficient antioxidants to meet the requirements in Specification **D3350**.

5.3.3.2 Only polyethylene plastics meeting the requirement of Grade PE27 as defined in Specification **D3350** shall be used

TABLE 2 Wall Thickness for PE-AL-PE Composite Pipe

| Nominal Pipe Size, mm (in.) | Total Wall Thickness, min, mm (in.) | Wall Tolerance (+) mm | Outer PE Layer Thickness, min, mm (in.) | Inner PE Layer Thickness, min, mm (in.) |
|-----------------------------|-------------------------------------|-----------------------|---|---|
| 0912 (3/8) | 1.60 (0.063) | 0.40 (0.016) | 0.40 (0.016) | 0.70 (0.028) |
| 1216 (1/2) | 1.65 (0.065) | 0.40 (0.016) | 0.40 (0.016) | 0.90 (0.035) |
| 1620 (5/8) | 1.90 (0.075) | 0.40 (0.016) | 0.40 (0.016) | 1.00 (0.039) |
| 2025 (3/4) | 2.25 (0.089) | 0.50 (0.020) | 0.40 (0.016) | 1.10 (0.043) |
| 2532 (1) | 2.90 (0.114) | 0.60 (0.024) | 0.40 (0.016) | 1.20 (0.047) |
| 3240 (1 1/4) | 3.85 (0.152) | 0.60 (0.024) | 0.40 (0.016) | 1.70 (0.067) |
| 4150 (1 1/2) | 4.35 (0.171) | 0.60 (0.024) | 0.40 (0.016) | 1.70 (0.067) |
| 5163 (2) | 5.80 (0.228) | 0.60 (0.024) | 0.40 (0.016) | 2.05 (0.081) |
| 6075 (2 1/2) | 7.25 (0.285) | 0.60 (0.024) | 0.40 (0.016) | 2.80 (0.110) |

to manufacture pipe rated at 82°C (180°F). The PE27 shall be an ethylene-octene copolymer having a PPI listing for 82°C (180°F).

5.3.4 The polyethylene compound used shall meet the minimum 80°C (176°F) temperature stress rupture lifetimes for pipe as specified in Table 7 of Specification **D3035**.

5.4 *Melt Adhesive*—The material shall have a density cell of 1, 2, or 3; a melt index cell of 1, 2, or 3; and a color code of A or B, in accordance with Specification **D3350**.

5.5 *Rework Material*—Clean rework material, generated from the manufacturer’s own production, may be used by the same manufacturer, as long as the pipe produced meets all of the requirements of this specification. Rework material containing aluminum or reprocessed or recycled plastics shall not be used for the production of pipe.

6. Requirements

6.1 *General*—The requirements and test methods in this specification cover PE-AL-PE pipes. Tests on the individual layers that comprise this composite pipe are outside the scope of this specification. The raw materials used, however, must conform to the requirements in Section 5.

6.2 Dimensions and Tolerances of Pipe:

6.2.1 *Pipe Diameter*—The minimum outside diameter and tolerances of the pipe shall meet the requirements given in **Table 1**, when measured in accordance with **9.1** and **9.1.2**. Maximum and minimum (out-of-roundness) tolerances apply only to measurements made on pipe prior to coiling.

6.2.2 *Pipe Wall Thickness*—The total pipe wall thickness shall meet the requirements given in **Table 2**, when measured in accordance with **9.1** and **9.1.3**. The minimum wall thickness at any point of measurement of the pipe shall not be less than the minimum wall thickness specified in **Table 2**.

6.2.3 *Outer Polyethylene Layer Thickness*—The thickness of the outer layer of polyethylene in the PE-AL-PE pipe shall have a minimum value and tolerance as specified in **Table 2**, except for the polyethylene material overlaying the weld, which shall have a minimum thickness of half that specified in **Table 2**. The polyethylene thickness is measured in accordance with **9.2**.

6.2.4 *Pipe Length*—The pipe shall be supplied coiled or in straight lengths as agreed upon with the purchaser with an allowable tolerance of -0 mm.

6.3 Adhesion Test:

6.3.1 For Sizes 0912 (3/8) to 2532 (1) there shall be no delamination of the PE and AL, either on the bore side or the outside (see **Fig. 1**). The test shall be conducted in accordance with **9.3.1**.

6.3.2 The adhesion test of the PE-layer to the aluminum for Sizes 3240 (1 1/4) to 6075 (2 1/2) is carried out by a separation test. The minimum adhesive force is specified in **Table 3**. The adhesive force shall not fall below these levels. The test shall be conducted in accordance with **9.3.2**.

6.4 *Apparent Tensile Strength of Pipe*—The pipe rings, when tested in accordance with **9.4**, shall meet the minimum strength as specified in **Table 4**.

6.5 *Minimum Burst Pressure*—The minimum burst pressure for PE-AL-PE pipe shall be as given in **Table 4**, when determined in accordance with **9.5**.

6.6 Sustained Pressure:

6.6.1 The PE-AL-PE pipe rated at 60°C (140°F) shall not fail, balloon, burst, or weep, as defined in Test Method **D1598**, when tested for 10 h at the test pressure given in **Table 5** at a temperature of 60°C (140°F) in accordance with **9.6**.

6.6.2 PE-AL-PE pipe rated at 82°C (180°F) shall not fail, balloon, burst, or weep as defined in Test Method **D1598** when tested in accordance with **9.6** for 10 h at the test pressure given in **Table 5** at a temperature of 82°C (180°F).

7. Workmanship

7.1 The pipe shall be free of visible cracks, holes, foreign inclusions, blisters, and other known injurious defects. The pipe shall be as uniform as commercially practicable in color, opacity, and regularity of the distribution of the polyethylene inside and outside.

8. Sampling and Conditioning

8.1 *Sampling*—Take a sample of the PE-AL-PE pipe sufficient to determine conformance with this specification. The number of specimens designated for each test shall be taken from pipe selected at random in accordance with the random sampling plan of Practice **D1898**.

NOTE 1—Sample size and testing frequency of lots for quality control must be established by the manufacturer to ensure conformance to the specification. Sampling and frequency will vary with the specific circumstances.

8.2 *Test Specimens*—Not less than 50 % of the test specimens required for any pressure test shall have at least part of

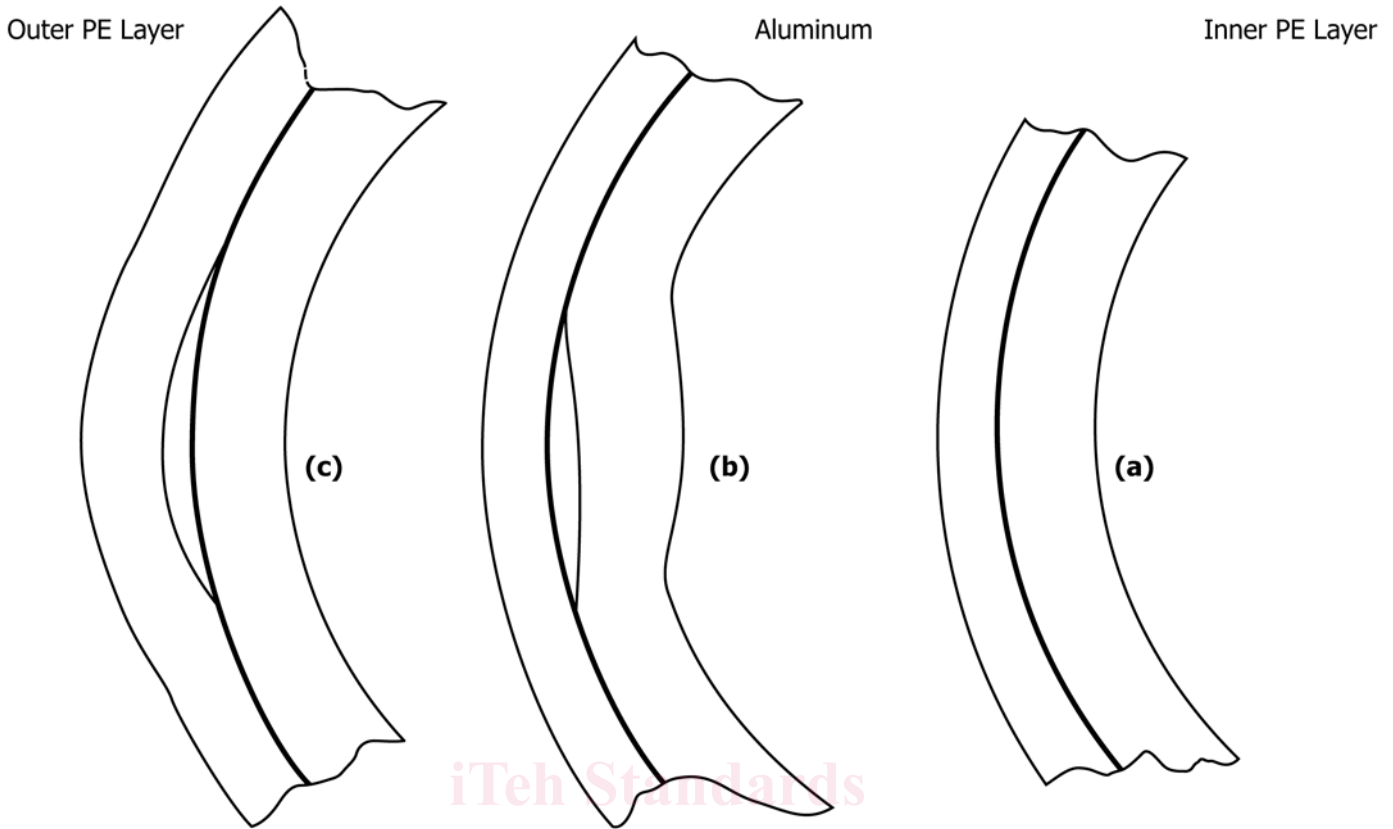

NOTE 1—(a) Good pipe showing no delamination, (b) Delamination between the inner layer and the aluminum, and (c) Delamination between the outer layer and the aluminum.

FIG. 1 Detection of Delamination

TABLE 3 Minimum Adhesive Force for PE-AL-PE Composite Pipe

| Nominal Pipe Size, mm (in.) | Minimum Adhesive Force per 10-mm (0.394-in.) Pipe Strip, N (lbf) |
|-----------------------------|--|
| 3240 (1¼) | 40 (9.0) |
| 4150 (1½) | 50 (11.2) |
| 5163 (2) | 60 (13.5) |
| 6075 (2½) | 70 (15.7) |

Practice D618, for those tests where conditioning is required. In cases of disagreement, the tolerances shall be ±1°C (±1.8°F) and ±2 % relative humidity.

8.4 Test Conditions—Conduct the test in the standard laboratory atmosphere of 23 ± 2°C (73.4 ± 3.6°F) and 50 ± 5 % relative humidity, unless otherwise specified in the test methods or in this specification. In cases of disagreement, the tolerances shall be ±1°C (1.8°F) and ±2 % relative humidity.

TABLE 4 Minimum Pipe Ring Strengths and 23°C (73.4°F) Burst Pressure of PE-AL-PE Composite Pipe

| Nominal Pipe Size, mm (in.) | Minimum Pipe Ring Strength, Type II PE, N (lb) | Minimum Pipe Ring Strength, Type III PE, N (lb) | Minimum 23°C (73.4°F) Burst Pressure, kPa (psi) |
|-----------------------------|--|---|---|
| | 0912 (¾) | 2000 (448) | 2100 (470) |
| 1216 (½) | 2100 (470) | 2300 (515) | 6000 (880) |
| 1620 (5/8) | 2400 (538) | 2500 (560) | 5000 (730) |
| 2025 (¾) | 2400 (538) | 2500 (560) | 4000 (580) |
| 2532 (1) | 2650 (598) | 2500 (560) | 4000 (580) |
| 3240 (1¼) | 3200 (719) | 3500 (789) | 4000 (580) |
| 4150 (1½) | 3500 (789) | 3700 (832) | 3800 (554) |
| 5163 (2) | 5200 (1169) | 5500 (1236) | 3800 (554) |
| 6075 (2½) | 6000 (1349) | 6000 (1349) | 3800 (554) |

9. Test Methods

9.1 Dimensions and Tolerances:

9.1.1 Pipe—Any length of the PE-AL-PE composite pipe may be used to determine dimensions.

9.1.2 Outside Diameter—Measure the outside diameter of the PE-AL-PE pipe in accordance with Test Method D2122.

9.1.3 Wall Thickness—Make micrometre measurements of the wall thickness in accordance with Test Method D2122 to determine the maximum and minimum values. Measure the wall thickness at both ends of the pipe to the nearest 0.01 mm (0.0004 in.).

9.2 Outer Polyethylene Layer Thickness:

9.2.1 Sample Preparation—Select the sample of pipe at random. Cut the pipe with a sharp knife or other suitable cutter, ensuring that the pipe after cutting is not more than 10 % out-of-round.

9.2.2 Thickness Determination—Use a hand held magnifying glass equipped with graduated reticule, or a laboratory

the marking in their central sections. The central section is that portion of the pipe that is at least one pipe diameter away from an end closure.

8.3 Conditioning—Condition the specimens at 23 ± 2°C (73.4 ± 3.6°F) and 50 ± 5 % relative humidity for not less than 40 h prior to test in accordance with Procedure A of

TABLE 5 Minimum Sustained Pressure for PE-AL-PE Composite Pipe

| Nominal Pipe Size, mm (in.) | Minimum Sustained Pressure PE-AL-PE, kPa (psi) | Minimum Sustained Pressure PE-AL-PE, kPa at 82°C (psi at 180°F) |
|-----------------------------|--|---|
| 0912 (3/8) | 2480 (360) | 2340 (340) |
| 1216 (1/2) | 2480 (360) | 2340 (340) |
| 1620 (5/8) | 2480 (360) | 2340 (340) |
| 2025 (3/4) | 2480 (360) | 2340 (340) |
| 2532 (1) | 2480 (360) | 2340 (340) |
| 3240 (1 1/4) | 2100 (305) | ... |
| 4150 (1 1/2) | 2100 (305) | ... |
| 5163 (2) | 2100 (305) | ... |
| 6075 (2 1/2) | 2100 (305) | ... |

microscope with graduated reticule. The reticule should measure to the nearest 0.1 mm (0.004 in.). Determine the thickness of the outer coating of polyethylene at six points around the circumference. Only one of the points should be at the aluminum weld.

9.3 Adhesion Test:

9.3.1 Visual Test:

9.3.1.1 Cutting the Spiral—Mount a Stanley 1991 or similarly sharp but rigid razor-like blade within a protective housing and angle to cut a $45 \pm 5^\circ$ spiral in the pipe (see Fig. 2). Choose a PEX-AL-PEX pipe at random and insert into the housing and rotate to form the spiral cut. The cut goes through the complete wall on one side of the pipe only. Run the spiral along the pipe for a minimum distance along the pipe axis equal to five times the outside diameter.

9.3.1.2 Examining for Delamination—Firmly hold the pipe with the spiral cut at the uncut end and create a ribbon of pipe material by opening out the spiral-cut pipe. Pliers can be used to grip the spiral-cut pipe. Examine the wall of the pipe visually side-on for evidence of delamination between the metal and plastic layers (see Fig. 1).

9.3.2 Separation Test:

9.3.2.1 Specimen—Five pipe sections of 10-mm (0.394-in.) length are cut at random intervals. The outer layers of the pipe (outer PE-layer together with the aluminum) are separated mechanically from the inner PE-layer with an appropriate device on the opposite side to the welding seam. The outer layers are separated on one side to about 5 mm from the pipe in order to allow clamping. The adhesion for the outer PE-layer to the aluminum is then visually examined for delamination at the corresponding test sample.

9.3.2.2 Test Equipment:

(1) Tension Testing Device, with suitable pull-off device (see Fig. 3).

(2) $D_{roller} = 95\%$ of the required pipe inner diameter.

(3) $d_i =$ pipe inner diameter.

9.3.2.3 Test Procedure—Remove the outer layers from the pipe at $23 \pm 2^\circ\text{C}$ ($73.4 \pm 3.6^\circ\text{F}$) with a linear speed of 50 mm/min (≈ 2 in./min). Record the force diagram.

9.4 Ring Test:

9.4.1 Sample Size and Shape—Cut rings of the PE-AL-PE pipe so that the two sides are parallel and at $90 \pm 2^\circ$ to the pipe axis. The length of each ring shall be 25 ± 1 mm (1 ± 0.04 in.). Cut a minimum of 15 samples consecutively along the axis of the pipe.

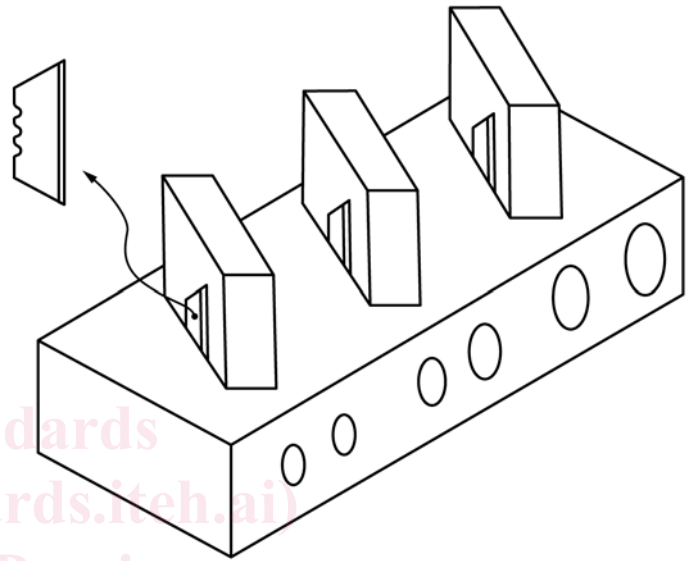

FIG. 2 Spiral Cutter for the Delamination Test

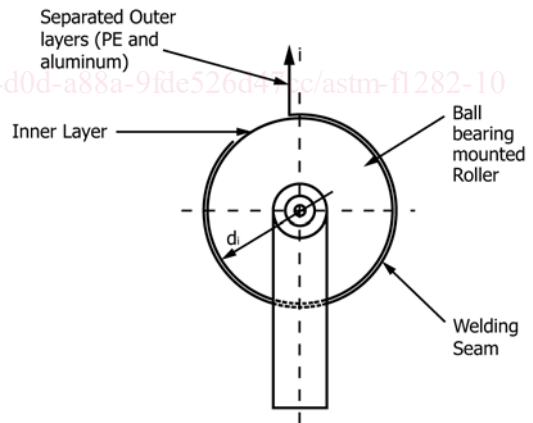

FIG. 3 Setup for Separation Test

9.4.2 Ring Tests—Test the 15 consecutively cut samples using a tensile testing machine. Arrange the rings so that the aluminum weld is at 90° to the tensile axis as shown in Fig. 4. The crosshead speed shall be 50 ± 2.5 mm/min (2 ± 0.1 in./min). Mount the rings of pipe on two steel rods of minimum diameter of 4 mm (0.16 in.). Record the peak force.

9.5 Burst Pressure:

9.5.1 Pipe Sample—Select a length of PE-AL-PE pipe at random and prepare five consecutive lengths of 300 ± 5 mm

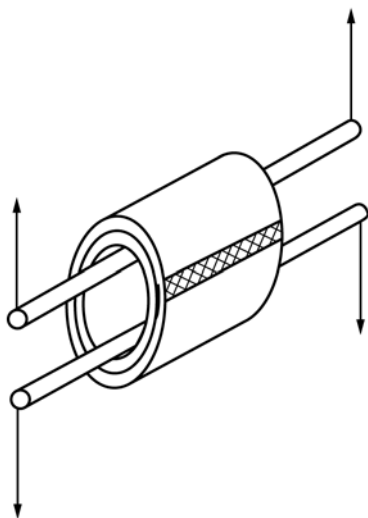

FIG. 4 Schematic Presentation of the Pipe Ring Test Showing the Aluminum Weld at 90° to the Tensile Axis

(12 ± 0.2 in.). Seal samples at the ends with the appropriate fittings and test either free- or fixed-end.

9.5.2 *Temperature Control*—Test samples at a temperature of 23 ± 2°C (73.4 ± 3.6°F). Contain samples either in a temperature-controlled water bath or in air (at standard laboratory atmosphere). For samples contained in a water bath, 1 h conditioning is required. For samples tested in air, a 16 h conditioning period is required.

9.5.3 *Burst Pressure*—Determine the burst pressure in accordance with the procedure in Test Method D1599.

9.6 Sustained Pressure Test:

9.6.1 *Samples*—Each test sample of PE-AL-PE pipe shall have a minimum length between end closures of at least ten times the average outside diameter, but not less than 250 mm (10 in.). Seal specimens at both ends with the appropriate fittings and fill the samples for testing with potable drinking water.

9.6.2 *Test Procedures*—Test each sample individually in a temperature controlled water bath or in air in accordance with Test Method D1598. Test at 60 ± 2°C (140 ± 3.6°F) or 82 ± 2°C (180 ± 3.6°F) in accordance with 6.6. For each pipe size test six samples. For testing in a water bath, condition the test samples for at least 2 h in the water bath at the test temperature

prior to pressurization. For testing in air, condition the samples for at least 4 h in air at the test temperature prior to pressurization. Maintain the pressure at the pressure given in Table 5 for the duration of the test.

9.6.3 *Failure*—Any continuous loss of pressure of the test sample shall constitute failure of the test. Failure of one of the six is cause for retest of six additional samples under identical conditions. Failure of one of six of the retested samples below the minimum specified lifetime constitutes failure of the test.

10. Quality Assurance

10.1 When the product is marked with this designation, ASTM F1282, the manufacturer affirms that the product was manufactured, inspected, sampled, and tested in accordance with this specification and has been found to meet the requirements of this specification. When specified in the purchase order or contract, a report of the test results shall be furnished.

11. Marking

11.1 *Quality of Marking*—The marking shall be applied to the pipe in such a manner that it remains legible (easily read) after installation and inspection.

11.2 Markings on the tubing shall include the following, spaced at intervals of not more than 1.5 m (5 ft):

11.2.1 Nominal tubing size (for example, 1216),

11.2.2 The material designation “PE-AL-PE,”

11.2.3 Pressure rating for water and temperature for which the pressure rating is valid,

11.2.4 ASTM designation F1282, with which the tubing complies, and

11.2.5 Manufacturer’s name (or trademark) and production code.

11.2.6 Tubing intended for the transport of potable water shall also include the seal or mark of the laboratory making the evaluation and the number of the standard used for the evaluation.

NOTE 2—Manufacturers using the seal or mark of a laboratory must obtain prior authorization from the laboratory concerned.

12. Keywords

12.1 composite; PE-AL-PE; pipe; polyethylene; pressure

SUPPLEMENTARY REQUIREMENTS

GOVERNMENT/MILITARY PROCUREMENT

These requirements apply *only* to Federal/Military procurement, not domestic sales or transfers.

S1. *Responsibility for Inspection*—Unless otherwise specified in the contract or purchase order, the producer is responsible for the performance of all inspection and test requirements specified herein. The producer may use his own or any other suitable facilities for the performance of the inspection and test requirements specified herein, unless disapproved by

the purchaser. The purchaser shall have the right to perform any of the inspections and tests set forth in this specification where such inspections are deemed necessary to ensure that material conforms to prescribed requirements.

NOTE S1.1—In U. S. Federal Government contracts, the contractor is responsible for inspection.