

# INTERNATIONAL STANDARD

**ISO  
2409**

Second edition  
1992-08-15

---

---

## Paints and varnishes — Cross-cut test

*Peintures et vernis — Essai de quadrillage*

**iTeh STANDARD PREVIEW**  
**(standards.iteh.ai)**

ISO 2409:1992

<https://standards.iteh.ai/catalog/standards/sist/beb55613-0bfa-4f75-a73f-db1be2264343/iso-2409-1992>



Reference number  
ISO 2409:1992(E)

## Foreword

ISO (the International Organization for Standardization) is a worldwide federation of national standards bodies (ISO member bodies). The work of preparing International Standards is normally carried out through ISO technical committees. Each member body interested in a subject for which a technical committee has been established has the right to be represented on that committee. International organizations, governmental and non-governmental, in liaison with ISO, also take part in the work. ISO collaborates closely with the International Electrotechnical Commission (IEC) on all matters of electrotechnical standardization.

Draft International Standards adopted by the technical committees are circulated to the member bodies for voting. Publication as an International Standard requires approval by at least 75% of the member bodies casting a vote.

International Standard ISO 2409 was prepared by Technical Committee ISO/TC 35, *Paints and varnishes*, Sub-Committee SC 9, *General test methods for paints and varnishes*.

ISO 2409:1992

This second edition cancels and replaces the first edition (ISO 2409:1972), which has been technically revised. The main technical changes in this second edition are that, in the procedure, the spacing of the cuts is prescribed, depending on the thickness of the coating and the type of substrate, and that for hard substrates application of adhesive tape has been added.

Annex A forms an integral part of this International Standard.

© ISO 1992

All rights reserved. No part of this publication may be reproduced or utilized in any form or by any means, electronic or mechanical, including photocopying and microfilm, without permission in writing from the publisher.

International Organization for Standardization  
Case Postale 56 • CH-1211 Genève 20 • Switzerland

Printed in Switzerland

# Paints and varnishes — Cross-cut test

## 1 Scope

**1.1** This International Standard is one of a series of standards dealing with the sampling and testing of paints, varnishes and related products. It specifies a test method for assessing the resistance of paint coatings to separation from substrates when a right-angle lattice pattern is cut into the coating, penetrating through to the substrate. The property measured by this empirical test procedure depends, among other factors, on the adhesion of the coating to either the preceding coat or the substrate. This procedure is not to be regarded, however, as a means of measuring adhesion.

Where a measurement of adhesion is required, attention is drawn to the method described in ISO 4624:1978, *Paints and varnishes — Pull-off test for adhesion*.

**NOTE 1** Although the test is primarily intended for use in the laboratory, the test is also suitable for field testing.

**1.2** The method described may be applied either as a pass/fail test or, where circumstances are appropriate, as a six-step classification test (see 8.3). When applied to a multi-coat system, assessment of the resistance to separation of individual layers of the coating from each other may be made.

**1.3** The test may be carried out on finished objects and/or on specially prepared test specimens.

Although the method is applicable to paint on hard (steel) and soft (wood and plaster) substrates, these different substrates need a different test procedure (see clause 7).

The method is not suitable for coatings of total thickness greater than 250  $\mu\text{m}$  or for textured coatings.

1) To be published. (Revision of ISO 1513:1980)

2) To be published. (Revision of ISO 1514:1984)

## NOTES

2 Coatings with a total thickness of over 250  $\mu\text{m}$  may be tested by means of a single cross-cut.

3 The method, when applied to coatings designed to give a rough patterned surface, will give results which will show too much variation.

## 2 Normative references

The following standards contain provisions which, through reference in this text, constitute provisions of this International Standard. At the time of publication, the editions indicated were valid. All standards are subject to revision, and parties to agreements based on this International Standard are encouraged to investigate the possibility of applying the most recent editions of the standards indicated below. Members of IEC and ISO maintain registers of currently valid International Standards.

ISO 1512:1991, *Paints and varnishes — Sampling of products in liquid or paste form*.

ISO 1513:—<sup>1)</sup>, *Paints and varnishes — Examination and preparation of samples for testing*.

ISO 1514:—<sup>2)</sup>, *Paints and varnishes — Standard panels for testing*.

ISO 2808:1991, *Paints and varnishes — Determination of film thickness*.

ISO 3270:1984, *Paints and varnishes and their raw materials — Temperatures and humidities for conditioning and testing*.

IEC 454-2:1974, *Specifications for pressure-sensitive adhesive tapes for electrical purposes — Part 2: Methods of test*.

### 3 Required supplementary information

For any particular application, the test method specified in this International Standard needs to be completed by supplementary information. The items of supplementary information are given in annex A.

### 4 Apparatus

Ordinary laboratory apparatus, together with the following:

#### 4.1 Cutting tool.

It is particularly important to ensure that the cutting tool has a defined shape and that the cutting edges are in good condition.

4.1.1 Suitable tools are listed below and shown in figures 1 a) and 1 b):

- a) single-blade cutting tool with 20° to 30° edge and other dimensions as specified in figure 1 a);
- b) multi-blade cutting tool with six cutting edges spaced 1 mm or 2 mm apart.

The single-blade cutting tool is the preferred tool in all cases, i.e. with all kinds of coating on both hard and soft substrates. The multi-blade cutting tool is not suitable for thick (> 120 µm) or hard coatings or where the coating is applied over soft substrates.

4.1.2 The tools specified in 4.1.1 are suitable for manual use and, although this is the more usual method of use, the tool may be mounted on a motor-driven apparatus which gives more uniform cutting. The application of the latter procedure shall be subject to agreement between the interested parties.

#### 4.2 Guiding and spacing edges.

In order to space the cuts correctly, a series of guiding and spacing edges is necessary when using a single-blade cutting tool. A suitable apparatus is shown in figure 2.

#### 4.3 Soft brush.

4.4 Transparent pressure-sensitive adhesive tape, 25 mm wide, with an adhesion strength of (10 ± 1) N per 25 mm width when tested in accordance with IEC 454-2.

4.5 Viewing lens, hand-held, with a magnification of × 2 or × 3.

### 5 Sampling

Take a representative sample of the product to be tested, as described in ISO 1512.

Examine and prepare each sample for testing, as described in ISO 1513.

### 6 Test panels

#### 6.1 Substrate

Unless otherwise agreed, select the substrate from one of those described in ISO 1514.

The panels shall be plane and free from distortion. The dimensions shall be such as to allow the test to be carried out at three different positions being not less than 5 mm from each other and from an edge of the panel.

Where panels consist of a relatively soft material such as wood, the minimum thickness shall be 10 mm. Where panels consist of a hard material, the minimum thickness shall be 0,25 mm.

#### NOTES

4 Rectangular panels, measuring approximately 150 mm × 100 mm, have been found to be convenient.

5 In cases where the panel is made of wood, the direction and the structure of the grain may influence the test, and a pronounced grain will render the evaluation impossible.

#### 6.2 Preparation and coating

Unless otherwise agreed, prepare each test panel in accordance with ISO 1514 and then coat it by the specified method with the product or system under test.

#### 6.3 Drying

Dry (or stove) and age (if applicable) each coated test panel for the specified time and under the specified conditions.

#### 6.4 Thickness of coating

Determine the thickness, in micrometres, of the dried coating by one of the procedures specified in ISO 2808. Make the measurement at, or as near as possible to, the positions at which the cross-cut is to be made. The number of thickness determinations is dependent on the method used.

## 7 Procedure

### 7.1 General

#### 7.1.1 Test conditions and number of tests

Carry out the test at a temperature of  $(23 \pm 2)$  °C and a relative humidity of  $(50 \pm 5)$  %, unless otherwise agreed (see also ISO 3270).

NOTE 6 In field tests, the ambient conditions will have to be accepted.

Carry out the test in at least three different places (see 6.1) on the panel (see also 8.1). If the results do not agree, the differences being more than one classification unit, repeat the test at three more places, if necessary using different panels, and record all the results.

#### 7.1.2 Conditioning of the test panels

Unless otherwise specified, condition the test panels immediately prior to the test at a temperature of  $(23 \pm 2)$  °C and a relative humidity of  $(50 \pm 5)$  % for a minimum of 16 h.

#### 7.1.3 Number of cuts

The number of cuts in each direction of the lattice pattern shall be six.

#### 7.1.4 Spacing of cuts

The spacing of the cuts in each direction shall be equal and shall depend on the thickness of the coating and on the type of substrate as follows:

0 µm to 60 µm:	1 mm spacing, for hard substrates;
0 µm to 60 µm:	2 mm spacing, for soft substrates;
61 µm to 120 µm:	2 mm spacing, for both hard and soft substrates;
121 µm to 250 µm:	3 mm spacing, for both hard and soft substrates.

### 7.2 Cutting and removing the coating using the manual procedure

7.2.1 Place the test panel on a rigid, flat surface to prevent any deformation of the panel during the test.

7.2.2 Perform the cutting manually following the specified procedure.

Before the test, inspect the cutting edge of the blade

and maintain its condition by sharpening or replacement.

If the panel is of wood or similar material, make the cuts at approximately 45° to the direction of the grain.

7.2.3 Hold the cutting tool (4.1) with the blade normal to the test panel surface. With uniform pressure on the cutting tool and using the appropriate spacing guide (4.2), make the agreed number of cuts in the coating at a uniform cutting rate. All the cuts shall penetrate to the substrate surface.

If it is not possible, due to the hardness of the coating, to penetrate to the substrate, the test shall be declared invalid and so reported.

7.2.4 Repeat this operation, making further parallel cuts of equal number, crossing the original cuts at 90° to them so that a lattice pattern is formed.

7.2.5 Brush the panel lightly with the soft brush (4.3) several times backwards and several times forwards along each of the diagonals of the lattice pattern.

7.2.6 For hard substrates only, apply additionally adhesive tape (4.4). If beginning a new series of tests, remove two complete laps from a reel of the adhesive tape and discard. Remove an additional length at a steady rate and cut a piece approximately 75 mm long.

Place the centre of the tape over the lattice in a direction parallel to one set of cuts as shown in figure 3 and smooth the tape into place over the area of the lattice and for a distance of at least 20 mm beyond with a finger.

To ensure good contact with the coating, rub the tape firmly with a fingertip. The colour of the coating seen through the tape is a useful indication of overall contact.

Within 5 min of applying the tape, remove the tape by grasping the free end and pulling it off steadily in 0.5 s to 1.0 s at an angle which is as close as possible to 60° (see figure 3).

7.2.7 Retain the tape for reference purposes, for example by attaching it to a sheet of transparent film.

### 7.3 Cutting the coating using a motor-driven tool

If the cutting tool is used with a motor-driven apparatus, take care that the points described in the manual procedure are observed, particularly with respect to the number and spacing of the cuts and the number of tests.

## 8 Expression of results

**8.1** Carry out the evaluation of the results as follows:

- soft substrates: immediately following brushing;
- hard substrates: immediately following removal of adhesive tape.

**8.2** Carefully examine the cut area of the test coating in good lighting using normal or corrected vision or, if agreed between the interested parties, using a viewing lens (4.5). During the viewing process, rotate the panel so that the viewing and lighting of the test area are not confined to one direction. It may be useful to examine the tape in a similar manner.

**8.3** Classify the test area according to table 1, by comparison with the illustrations.

NOTE 7 Additional guidance is given by the descriptions given in table 1.

In table 1, a six-step classification is given. The first three steps are satisfactory for general purposes and are to be used when a pass/fail assessment is required. Special circumstances may arise, in which case the complete six-step classification will be necessary.

**8.4** For a multi-coat system, report the interface at which any flaking occurs.

**8.5** If test results differ, report each test result. In the case of a multi-coat system, report the site of separation (between coats or between coats and substrates).

## 9 Test report

The test report shall contain at least the following information:

- a) all details necessary to identify the product tested;
- b) a reference to this International Standard (ISO 2409);
- c) the items of supplementary information referred to in annex A, in particular the type of cutting tool used;
- d) a reference to the international or national standard, product specification or other document supplying the information referred to in c);
- e) the results of the test, as indicated in clause 8;
- f) any deviation from the test method specified;
- g) the date of the test.

ISO 2409:1992  
<https://standards.iteh.ai/catalog/standards/sist/beb55613-0bfa-4f75-a73f-db1be2264343/iso-2409-1992>

Table 1 — Classification of test results

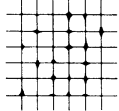
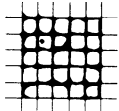
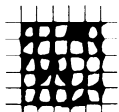
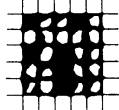
Classification	Description	Appearance of surface of cross-cut area from which flaking has occurred (Example for six parallel cuts)
0	The edges of the cuts are completely smooth: none of the squares of the lattice is detached.	
1	Detachment of small flakes of the coating at the intersections of the cuts. A cross-cut area not significantly greater than 5 % is affected.	
2	The coating has flaked along the edges and/or at the intersections of the cuts. A cross-cut area significantly greater than 5 %, but not significantly greater than 15 %, is affected.	
3	The coating has flaked along the edges of the cuts partly or wholly in large ribbons, and/or it has flaked partly or wholly on different parts of the squares. A cross-cut area significantly greater than 15 %, but not significantly greater than 35 %, is affected.	
4	The coating has flaked along the edges of the cuts in large ribbons and/or some squares have detached partly or wholly. A cross-cut area significantly greater than 35 %, but not significantly greater than 65 %, is affected.	
5	Any degree of flaking that cannot even be classified by classification 4.	

ISO 2409:1992

<https://standards.iteh.ai/catalog/standards/sist/beb55613-0bfa-4f75-a73f-db1be2264343/iso-2409-1992>

Dimensions in millimetres, except where indicated otherwise

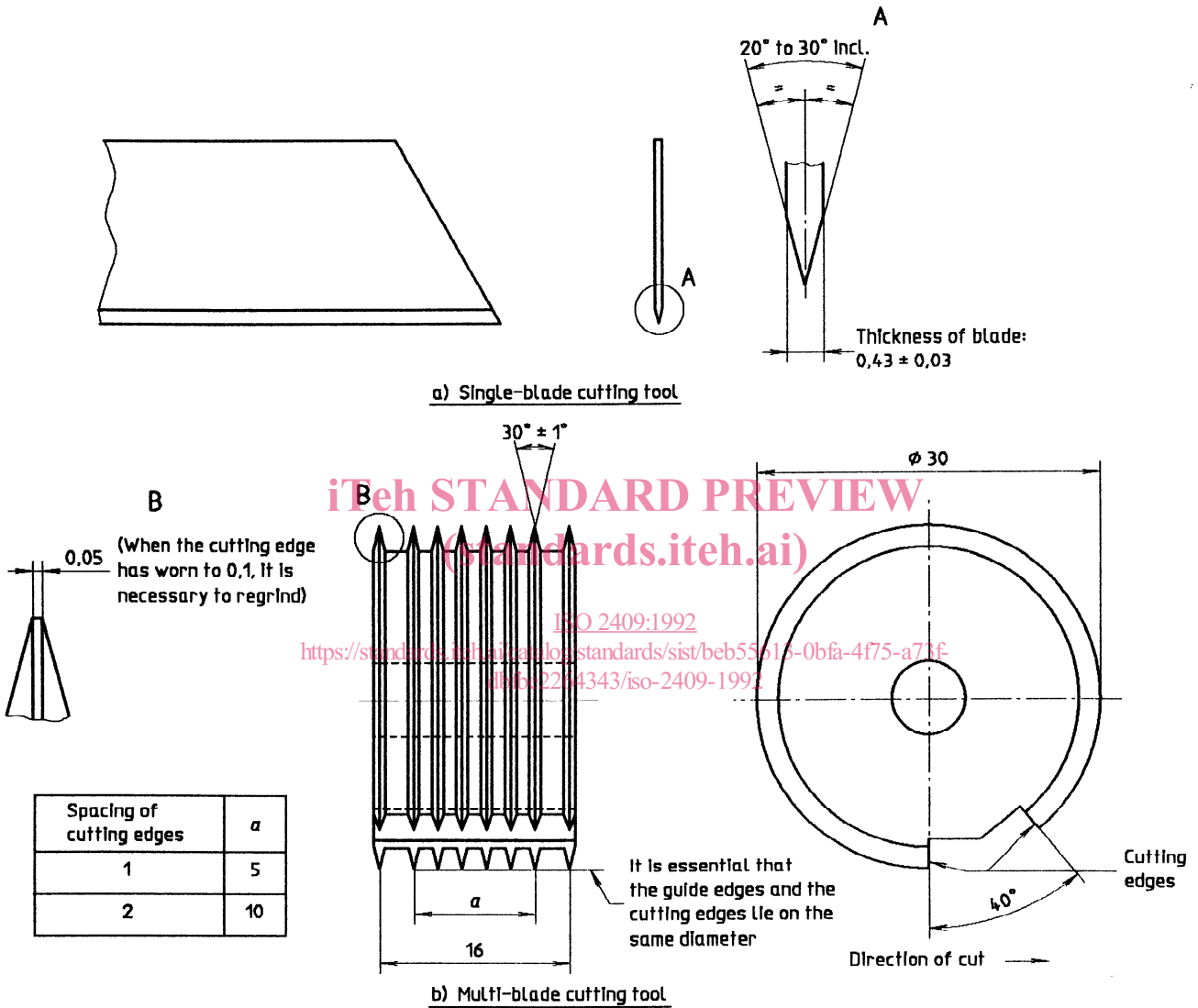
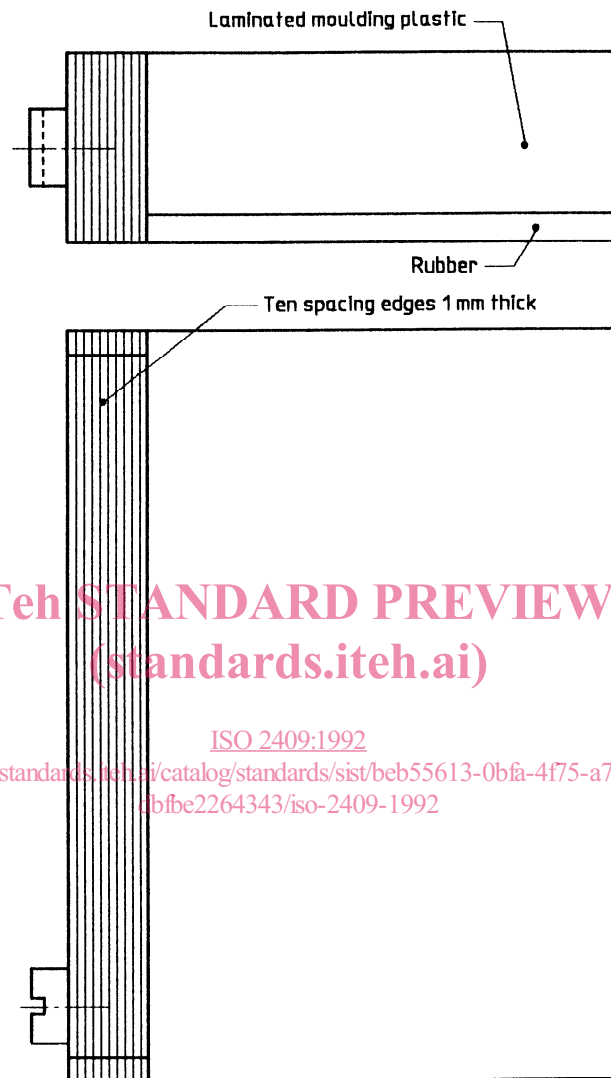

Figure 1 — Suitable cutting tools





**iTeh STANDARD PREVIEW**  
(standards.iteh.ai)

ISO 2409:1992

<https://standards.iteh.ai/catalog/standards/sist/beb55613-0bfa-4f75-a73f-bbfe2264343/iso-2409-1992>

Figure 2 — Series of spacing edges