



Designation: D7511 – 09^{ε1}

Standard Test Method for Total Cyanide by Segmented Flow Injection Analysis, In-Line Ultraviolet Digestion and Amperometric Detection¹

This standard is issued under the fixed designation D7511; the number immediately following the designation indicates the year of original adoption or, in the case of revision, the year of last revision. A number in parentheses indicates the year of last reapproval. A superscript epsilon (ϵ) indicates an editorial change since the last revision or reapproval.

^{ε1} NOTE—A typographical error was editorially corrected in Section 8.13 in March 2010.

1. Scope

1.1 This method is used for determining total cyanide in drinking and surface waters, as well as domestic and industrial wastes. Cyanide ion (CN^-), hydrogen cyanide in water ($\text{HCN}(\text{aq})$), and the cyano-complexes of zinc, copper, cadmium, mercury, nickel, silver, and iron may be determined by this method. Cyanide ions from Au(I), Co(III), Pd(II), and Ru(II) complexes are only partially determined.

1.2 The method detection limit (MDL) is 1.0 $\mu\text{g/L}$ cyanide and the minimum level (ML) is 3 $\mu\text{g/L}$. The applicable range of the method is 3 to 500 $\mu\text{g/L}$ cyanide using a 200- μL sample loop. Extend the range to analyze higher concentrations by sample dilution or changing the sample loop volume.

1.3 This method can be used by analysts experienced with equipment using segmented flow analysis (SFA) and flow injection analysis (FIA) or working under the close supervision of such qualified persons.

1.4 The values stated in SI units are to be regarded as standard. No other units of measurement are included in this standard.

1.5 *This standard does not purport to address all of the safety concerns, if any, associated with its use. It is the responsibility of the user of this standard to establish appropriate safety and health practices and determine the applicability of regulatory limitations prior to use.* Specific hazard statements are given in Note 2 and Section 9.

2. Referenced Documents

2.1 ASTM Standards:²

D1129 Terminology Relating to Water

¹ This test method is under the jurisdiction of ASTM Committee D19 on Water and is the direct responsibility of Subcommittee D19.06 on Methods for Analysis for Organic Substances in Water.

Current edition approved Feb. 15, 2009. Published March 2009. DOI: 10.1520/D7511-09.

² For referenced ASTM standards, visit the ASTM website, www.astm.org, or contact ASTM Customer Service at service@astm.org. For Annual Book of ASTM Standards volume information, refer to the standard's Document Summary page on the ASTM website.

D1193 Specification for Reagent Water

D2036 Test Methods for Cyanides in Water

D2777 Practice for Determination of Precision and Bias of Applicable Test Methods of Committee D19 on Water

D3370 Practices for Sampling Water from Closed Conduits

D3856 Guide for Good Laboratory Practices in Laboratories Engaged in Sampling and Analysis of Water

D4210 Practice for Intralaboratory Quality Control Procedures and a Discussion on Reporting Low-Level Data³

D5847 Practice for Writing Quality Control Specifications for Standard Test Methods for Water Analysis

D6696 Guide for Understanding Cyanide Species

D7365 Practice for Sampling, Preservation and Mitigating Interferences in Water Samples for Analysis of Cyanide

3. Terminology

3.1 *Definitions*—For definitions of terms used in this test method, refer to Terminology D1129 and Guide D6696.

3.1.1 *total cyanide*—refers to all cyanide-containing compounds in a sample, including free cyanide, WAD cyanide compounds, and strong metal cyanide complexes.

4. Summary of Test Method

4.1 Prior to analysis, treat the sample to remove potential interferences (Sections 4 and 8). Ultraviolet (UV) digestion releases cyanide from cyanide complexes. Acid addition converts cyanide ion to hydrogen cyanide gas (HCN), which passes under a gas diffusion membrane. The hydrogen cyanide gas diffuses through the membrane into an alkaline receiving solution, where it converts back to cyanide ion. A silver working electrode, silver/silver chloride reference electrode, and platinum/stainless steel counter electrode at an applied potential of zero volt amperometrically monitor the cyanide ion. The current generated is proportional to the cyanide concentration present in the original sample.

³ Withdrawn. The last approved version of this historical standard is referenced on www.astm.org.

4.2 Calibrations and data are processed with the instrument's data acquisition software.

5. Significance and Use

5.1 Cyanide and hydrogen cyanide are highly toxic. Regulations have been established to require the monitoring of cyanide in industrial and domestic wastewaters and surface waters.⁴

5.2 This test method is applicable for natural water, saline waters, and wastewater effluent.

5.3 The method may be used for process control in wastewater treatment facilities.

5.4 The spot test outlined in Test Methods D2036, Annex A1 can be used to detect cyanide and thiocyanate in water or wastewater, and to approximate its concentration.

6. Interferences

6.1 Method interferences can be caused by contaminants in the reagents, reagent water, glassware, etc., which may bias the results. Take care to keep all such items free of contaminants.

6.2 Sulfide and sulfide-containing compounds are positive interferences in this method. When acidified, sulfide forms hydrogen sulfide, which passes through the gas diffusion membrane and produces a signal at the silver electrode. In addition, sulfide ion reacts with cyanide ion in solution to reduce its concentration over time. Treat samples containing sulfide according to Section 11.4. During UV digestion, some sulfur compounds may produce sulfide. TA2 reagent contains a sulfide scrubber that can remove up to 50 mg/L S²⁻ from the system prior to amperometric detection.

6.3 Treat sample containing water-soluble aldehydes, such as formaldehyde or acetaldehyde, by adding ethylenediamine solution.

6.4 Remove oxidizing agents that decompose cyanides by adding ascorbic acid, or sodium arsenite.

6.5 Thiocyanate can produce positive interference when they decompose to cyanide by UV irradiation or oxidation. This method uses 312 nm as the irradiation wavelength, which keeps thiocyanate interference from UV irradiation minimal. Use of Total Acid Reagent–Modified, TA1M (see 8.21) minimizes interference from thiocyanate.

6.6 High concentrations of carbonate can result in a negative response in the amperometric detector when carbon dioxide diffuses across the gas diffusion membrane into the

alkaline receiving solution, reducing its pH. Treat effluents from high carbonate containing wastes, such as coal gasification waste and atmospheric emission scrub water, with hydrated lime to stabilize the sample.

6.7 High concentrations of surfactants interfere by changing the characteristics of the gas diffusion membrane, allowing acid solution to pass through the membrane and enter the detector.

6.8 Nitrate and nitrite if treated with sulfamic acid do not interfere in this method.

6.9 Sodium sulfite, sulfur dioxide, or sodium bisulfite do not interfere at up to 2000 ppm SO₃⁻.

6.10 Sodium Thiosulfate exhibits a slight positive bias at concentrations above 200 ppm. This positive bias may be removed by increasing the amount of Bismuth Nitrate in the TA2 reagent.

6.11 Samples containing particulates should be filtered prior to analysis. Extract and combine filtered extract with original sample prior to analysis, or measure the filtered extract and the aqueous sample separately and combine results mathematically.

7. Apparatus

7.1 The instrument should be equipped with a precise sample introduction system, a UV digester with a 312-nm lamp and TFE-efluorocarbon digestion coil, a gas diffusion manifold with hydrophobic membrane, and an amperometric detection system to include a silver working electrode, an Ag/AgCl reference electrode, and a Pt or stainless steel counter electrode. Examples of the apparatus schematics are shown in Fig. 1. Example instrument settings are shown in Table 1.⁵

NOTE 1—The instrument settings in Table 1 are only examples. The analyst may modify the settings as long as performance of the method has not been degraded. Contact the instrument manufacturer for recommended instrument parameters.

⁴ 40 CFR Part 136.

⁵ The sole source of supply of the apparatus known to the committee at this time is the trademarked CNSolution equipped with an amperometric flow cell, gas diffusion, and UV digestion module, available from OI Analytical. If you are aware of alternative suppliers, please provide this information to ASTM International Headquarters. Your comments will receive careful consideration at a meeting of the responsible technical committee,¹ which you may attend.

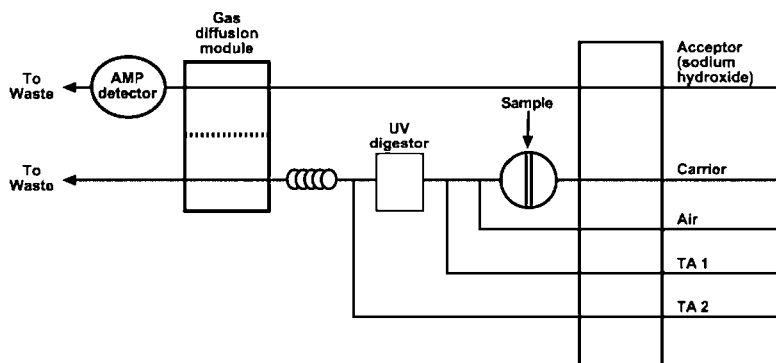

FIG. 1 Flow Injection Analysis Apparatus 1

TABLE 1 Flow Injection Analysis Parameters

FIA Instrument Parameter	Recommended Method Setting
Pump Flow Rates	0.5 to 2 mL/min
Cycle period (total)	90 to 250 s/sample
Sample load period	At least enough time to completely fill the sample loop
Reagent water rinse time between samples	At least 15 seconds
Peak Evaluation	Peak height or area
Working Potential	0.0 V vs Ag/AgCl

7.2 An autosampler is recommended but not required to automate sample injections and increase throughput. Auto samplers are usually available as an option from the instrument's manufacturer.

7.3 *Data Acquisition System*—Use the computer hardware and software recommended by the instrument manufacturer to control the apparatus and to collect data from the detector.

7.4 *Pump Tubing*—Use tubing recommended by instrument manufacturer. Replace pump tubing when worn, or when precision is no longer acceptable.

7.5 *Gas Diffusion Membranes*—A hydrophobic membrane which allows gaseous hydrogen cyanide to diffuse from the donor to the acceptor stream at a sufficient rate to allow detection. The gas diffusion membrane should be replaced when the baseline becomes noisy or every 1 to 2 weeks.⁶

7.6 Use parts and accessories as directed by instrument manufacturer.

8. Reagents and Materials

8.1 *Purity of Reagents*—Reagent grade chemicals shall be used in all tests. Unless otherwise indicated, it is intended that all reagents shall conform to the specifications of the American Chemical Society, where such specifications are available.⁷ Other grades may be used, provided it is first ascertained that the reagent is of sufficiently high purity to permit its use without lessening the accuracy of the determination.

8.2 *Purity of Water*—Unless otherwise indicated, references to water shall be understood to mean interference free reagent water conforming to Type I or Type II grade of Specification D1193.

8.3 *Sodium Hydroxide Solution (1.00 M)*—Dissolve 40 g NaOH in laboratory water and dilute to 1 L.

8.4 *Acceptor Solution (0.10 M NaOH)*—Dissolve 4.0 g NaOH in laboratory water and dilute to 1 L.

8.5 *Stock Cyanide Solution (1000 µg/mL CN⁻)*—Dissolve 2.51 g of KCN and 2.0 g of NaOH in 1 L of water. Standardize with silver nitrate solution as described in 8.5.1–8.5.4. Store the

solution under refrigeration and check concentration approximately every 6 months and correct if necessary.⁸

NOTE 2—**Warning:** Because KCN is highly toxic, avoid contact or inhalation.

8.5.1 Pipet 100 mL of Stock Cyanide Solution (see 8.5) into a 250 mL flask or beaker.

8.5.2 Add 0.5 mL of rhodanine indicator solution (see 8.17).

8.5.3 Titrate with standardized silver nitrate solution (see 8.18 and 8.18.2) to the first color change from yellow to salmon pink.

8.5.4 Record the results of the titration and calculate the cyanide concentration of the Stock Cyanide Solution according to the equation in 8.18.2.

8.5.5 Use the actual calculated cyanide concentration in all subsequent calculations of working standard concentrations.

8.6 *Intermediate Cyanide Standards:*

8.6.1 *Intermediate Standard 1 (100 µg/mL CN⁻)*—Pipette 10.0 mL of stock cyanide solution (see 8.5) into a 100 mL volumetric flask containing 1 mL of 1.0 M NaOH (see 8.3). Dilute to volume with laboratory water. Store under refrigeration. The standard should be stable for at least 2 weeks.

8.6.2 *Intermediate Cyanide Solution 2 (10 µg/mL CN⁻)*—Pipette 10.0 mL of Intermediate Cyanide Solution 1 (see 8.6.1) into a 100 mL volumetric flask containing 1.0 mL of 1.00 M NaOH (see 8.3). Dilute to volume with laboratory water. The standard should be stable for at least 2 weeks.

8.7 *Working Cyanide Calibration Standards*—Prepare fresh daily as described in 8.7.1 and 8.7.2 ranging in concentration from 3 to 500 µg/L CN⁻.

8.7.1 *Calibration Standards (20, 50, 100, 200, and 500 µg/L CN⁻)*—Pipette 20, 50, 100, 200, and 500 µL of Intermediate Standard 1 (see 8.6.1) into separate 100 mL volumetric flasks containing 1.0 mL of 1.00 M NaOH (see 8.3). Dilute to volume with laboratory water.

8.7.2 *Calibration Standards (3 and 10 µg/L CN⁻)*—Pipette 30 and 100 µL of Intermediate Cyanide Solution 2 (see 8.6.2) into separate 100 mL volumetric flasks containing 1.0 mL of 1.00 M NaOH (see 8.3). Dilute to volume with laboratory water.

8.8 *Cyanide Electrode Stabilization Solution (Approximately 5 ppm as CN⁻)*—Pipette 500 µL of Stock Cyanide (see 8.5) into a 100 mL volumetric flask containing 1.0 mL of 1.00 M NaOH (see 8.3). Dilute to volume with laboratory water. The solution should be stored under refrigeration.

8.9 *Acetate Buffer*—Dissolve 410 g of sodium acetate trihydrate (NaC₂H₃O₂·3H₂O) in 500 mL of laboratory water. Add glacial acetic acid (approximately 500 mL) to yield a pH of 4.5.

8.10 *Iron (II) Cyanide Stock Solution*—Weigh 0.2706 g K₄[Fe(CN)₆]·3H₂O into a 100 mL volumetric flask. Place 1.0 mL of 1.00 M NaOH (see 8.3) in the flask and dilute to volume with laboratory water. The solution must be stored in an amber glass bottle under refrigeration at 4°C.

8.11 *Iron (II) Cyanide Intermediate Solution*—Pipet 10.0 mL of the iron (II) cyanide stock solution (see 8.10) into a 100 mL volumetric flask containing 1.0 mL of 1.00 M NaOH (see

⁶ The sole source of supply of the apparatus known to the committee at this time is OI Analytical Part Number A001520 and Pall Corporation Part Number M5PU025. If you are aware of alternative suppliers, please provide this information to ASTM International Headquarters. Your comments will receive careful consideration at a meeting of the responsible technical committee,¹ which you may attend.

⁷ *Reagent Chemicals, American Chemical Society Specifications*, American Chemical Society, Washington, DC. For Suggestions on the testing of reagents not listed by the American Chemical Society, see *Annual Standards for Laboratory Chemicals*, BDH Ltd., Poole, Dorset, U.K., and the *United States Pharmacopeia and National Formulary*, U.S. Pharmacopeial Convention, Inc. (USPC), Rockville, MD.

⁸ Commercially available stock cyanide solutions may be substituted.

8.3). Dilute to volume with laboratory grade water. The solution must be stored in an amber glass bottle under refrigeration at 4°C.

8.12 *Iron (II) Cyanide Recovery Solution*—Pipet 100 µL of iron (II) cyanide intermediate solution (see 8.11) into a 100 mL volumetric flask containing 1.0 mL of 1.00 M NaOH (see 8.3). Dilute to volume with laboratory water. Prepare fresh daily.

8.13 *Iron (III) Cyanide Stock Solution*—Weigh 0.2109 g of $K_3Fe(CN)_6$ in a 100 mL volumetric flask. Place 1.0 mL of 1.00 M NaOH (see 8.3) in the flask and dilute to volume with laboratory water. The solution must be stored in an amber glass bottle under refrigeration at 4°C.

8.14 *Iron (III) Cyanide Intermediate Solution*—Pipet 10.0 mL of the iron (III) cyanide stock solution (see 8.13) into a 100 mL volumetric flask containing 1.0 mL of 1.00 M NaOH (see 8.3). Dilute to volume with laboratory grade water. The solution must be stored in an amber glass bottle under refrigeration at 4°C.

8.15 *Iron (III) Cyanide Recovery Solution*—Pipet 100 µL of iron (III) cyanide intermediate solution (see 8.14) into a 100 mL volumetric flask containing 1.0 mL of 1.00 M NaOH (see 8.3). Dilute to volume with laboratory water. Prepare fresh daily.

8.16 *Ag/AgCl Reference Electrode Filling Solution*—Fill the reference electrode as recommended by the instrument manufacturer.

8.17 *Rhodanine Indicator Solution (0.2 g/L)*—Dissolve 0.02 grams of (p-dimethylaminobenzylidene) in 100 mL acetone.

8.18 *Silver Nitrate Standard Solution (0.01 M)*—Dissolve 1.6987 g of silver nitrate ($AgNO_3$) in water and dilute to 1 L. Mix thoroughly. Commercial solutions that are certified at the designated normality are suitable if used within the manufacturer's recommended storage date, otherwise standardize as designated in sections 8.18.1 and 8.18.2. Store in a dark container.

8.18.1 *Potassium Chloride (KCl)—Primary Standard*—Purity 99.98 % minimum. Ignite KCl for 4 h at 500°C in a platinum or high silica vessel. Borosilicate vessels are unsatisfactory for this purpose. Store in a desiccator prior to use.

8.18.2 *Standardization*—Dissolve 1.000 g of primary standard KCl (see 8.18.1) in 150 mL water containing 1 mL of HNO_3 (1+1) in a 1-L volumetric flask, dilute to volume and mix. Transfer 15 mL of the 1g/L potassium chloride solution to a tared 250-mL beaker by pipet, record the weight to the nearest 0.01 g, dilute to about 100-mL with deionized water and titrate with 0.01 M Silver Nitrate titrant (see 8.18) using a silver indicator electrode or the Rhodanine Indicator Solution (see 8.17) for endpoint detection. Calculate the molarity of the titrant as follows:

$$A = 0.01341 B/C \quad (1)$$

where:

- A = molarity of titrant, moles/L,
 0.01341 = molarity of 1 g/L potassium chloride primary standard solution,
 B = weight of 1g/L potassium chloride solution titrated, and
 C = volume of silver nitrate consumed, mL.

8.19 *Total Acid Reagent 2 (TA2)*—Weigh 1.00 g bismuth nitrate pentahydrate, $Bi(NO_3)_3 \cdot 5H_2O$, into a 1 L volumetric flask. Add 55 mL of water then carefully add 55 mL of concentrated sulfuric acid to the flask. Gently swirl the flask until the bismuth nitrate pentahydrate has dissolved in the acid solution. Carefully add about 800 mL of ASTM Type II water to the volumetric flask. Cool to room temperature and add 20 mL of hypophosphorous acid. Dilute to volume and mix. **Warning:** This is an exothermic reaction and the solution will become hot when preparing this solution. Use this solution within 48 hours of preparation.

8.20 *Total Acid Reagent 1 (TA1)*—Carefully add 55 mL of concentrated sulfuric acid to about 800 mL of ASTM Type II water in a 1000 mL volumetric flask. Cool to room temperature and add 20 mL of hypophosphorous acid. Dilute to volume and mix. **Warning:** This is an exothermic reaction and the solution will become hot when preparing this solution. Use this solution within 48 hours of preparation.

8.21 *Total Acid Reagent 1—Modified (TA1M)*—Carefully add 55 mL of concentrated sulfuric acid to about 800 mL of ASTM Type II water in a 1000 mL volumetric flask and mix. Cool to room temperature and add 19 grams of Ascorbic acid and stir till dissolved. Add 19 grams citric acid stir till dissolved and dilute to 1000 mL with ASTM Type II water and mix.

8.21.1 The modified Total Acid Reagent 1 has been demonstrated to have less positive bias from thiocyanate (<0.1 %) than Total Acid Reagent 1 (~0.8 %), however, recoveries of Iron (III) Cyanide complexes may be slightly lower than recoveries using the Total Acid Reagent 1.

8.22 *Sodium Thiocyanate (1000 µg/mL SCN)*—Dissolve 0.3522 g NaSCN in 50 mL of ASTM Type II water in a 100-mL volumetric flask. Dilute to the mark with Type II water and mix. Store in an amber plastic or glass bottle away from light.

8.23 *Ethylenediamine Solution*—Dilute 3.5 mL of ethylenediamine to 100 mL with reagent water in a 100-mL volumetric flask and mix well.

9. Hazards

9.1 **Warning:** Because of the toxicity of cyanide, great care must be exercised in its handling. Acidification of cyanide solutions produces toxic hydrocyanic acid (HCN). All manipulations must be done in the hood so that any HCN gas that might escape is safely vented.

9.2 **Warning:** Many of the reagents used in these test methods are highly toxic. These reagents and their solutions must be disposed of properly.

9.3 All reagents and standards should be prepared in volumes consistent with laboratory use to minimize the generation of waste.

10. Sample and Sample Preservation

10.1 Collect the sample in accordance with Practices D3370 and D3856.

10.2 The sample may be stabilized at time of collection with the addition of sodium hydroxide (1 M is suitable for pH adjustment) until a pH of 12 to 12.5 is reached. See 11.1 if it is suspected that high levels of carbonate (>1500 ppm) are present in the sample.

10.3 Samples should be stored in dark bottles to minimize exposure to ultraviolet radiation, refrigerated between freezing and 6°C, and analyzed as soon as possible.

11. Elimination of Interferences

11.1 If samples are known to have high levels of CO_3^{2-} (above 1500 ppm), preserve the sample by adding 2 g/L $\text{Ca}(\text{OH})_2$ (hydrated lime) so that the pH is adjusted to $\text{pH} > 12$. Do not add NaOH to the sample as described in 10.2. Allow the $\text{Ca}(\text{OH})_2/\text{CaCO}_3$ solids to settle to the bottom of the container prior to analysis.

11.2 Treat samples containing or suspected to contain formaldehyde, acetaldehyde, or other water soluble aldehydes with 20 mL of 3.5 % ethylenediamine solution (see 8.20) per liter of sample.

11.3 *Oxidizing Agents*—Test for the presence of oxidizing agents. Add a drop of the sample to acidified KI starch test paper (acidify KI starch paper with acetate buffer, see 8.9) as soon as the sample is collected; a blue color indicates the need for treatment. If oxidizing agents are present or suspected, add 0.1 g/L sodium arsenite or 0.6 g/L ascorbic acid to the sample to avoid degradation of cyanide.

NOTE 3—If ascorbic acid is used, samples must be analyzed within 24 hours.

11.4 *Sulfide*—Test for the presence of sulfide by placing a drop of sample on a lead acetate test strip that has been previously moistened with acetate buffer. If the test strip turns black, sulfide is present (above 50 mg/L S^{2-}) and treatment is necessary as described in 11.4.1. If the test is negative and there are no further interferences suspected, adjust the pH to 12–13, refrigerate, and ship or transport to the laboratory.

11.4.1 If the sample contains sulfide as indicated with a lead acetate test strip or is known to contain sulfides that will interfere with the test method, dilute the sample with reagent water until the lead acetate test strip no longer indicates the presence of sulfide (<50 mg/L S^{2-}). For example, add 200-mL of freshly collected sample into a bottle containing 800-mL of reagent water, then test for sulfide again as indicated in 11.4. If the test for sulfide is negative, adjust the pH to 12–13, refrigerate, and ship or transport to the laboratory. If the test for sulfide is still positive, further dilution is required; however, be careful not to over dilute the sample as the detection limit will be elevated by this factor. In the aforementioned example, the dilution factor would be equal to 5 (total volume/sample volume). Clearly indicate the dilution volumes on the sample and chain-of-custody form so that the laboratory can mathematically correct the result.

NOTE 4—Some analytical methods prescribe the use of lead carbonate or lead acetate to precipitate sulfide; however, sulfide and cyanide can form thiocyanate in the presence of lead causing decreased cyanide recoveries; therefore, lead carbonate and lead acetate should be avoided. Methods that specify the addition of bismuth nitrate to treat sulfide during total cyanide distillations have been demonstrated by ASTM D19.06 to be ineffective.

NOTE 5—**Caution:** Cyanide can be converted into thiocyanate in the presence of sulfide at a high pH, causing high results.

11.5 *Samples Containing Solids*—Filter 50.0 mL of solid containing sample with 5 μm filter and save the filtrate for

analysis. Extract solids in 50 mL of 0.1 M NaOH solution (see 8.3) by placing the filter paper in a vial and submersing the filter with 0.1 M NaOH solution for at least 4 hours. Decant or filter the extract prior to analysis. Alternatively, if a syringe type filter can be used, filter 10.0 mL of solid containing sample with 5 μm filter and desorb the solids captured on the filter by slowly passing 5-mL of 0.1 M NaOH solution through the filter. Allow the wetted syringe filter to stand long enough to ensure that all cyanide complexes have been dissolved, then pass an additional 5-mL of 0.1 M NaOH solution through the filter. Analyze total cyanide on the sample filtrate and solids extract separately. If there is no significant cyanide detected in the solids extract, no colloidal cyanides are present and the extraction of the solids may not be necessary for future samples. In this case, simply filter the sample to remove suspended material and only analyze the sample filtrate for total cyanide. If cyanide is detected in the solids extract, colloidal cyanide is present and should be mathematically combined with the sample filtrate result.

11.6 Refer to the current Practice D7365 Standard Practice for Sampling, Preservation and Mitigating Interferences in Water Samples for the Analysis of Cyanide for more information. The practices specified in the most current Practice D7365 take precedence over sampling, preservation, and interference mitigation presented in this standard.

12. Calibration and Standardization

12.1 Turn on the power to the apparatus and the autosampler (if equipped). Start the data acquisition system.

12.2 Clamp the pump tube platens in place and start pumping reagents in the flow injection system. Allow the system to warm up at least 15 min or until a stable baseline is achieved. Take care not to over-tighten the pump tubes platens as this will greatly reduce their lifetime.

12.3 If recommended by the instrument manufacturer, aspirate the Cyanide Electrode Stabilization Solution (5 ppm CN^-) from 8.9. After at least 30 s, inject the shocking solution into the apparatus and record the amperometric response (pA value) after the cycle period has completed. Repeat this procedure until the peak responses are less than 3 % RSD. This process will ensure that the electrode system has stabilized.

12.4 After the electrode system has stabilized, aspirate the highest working standard (see 8.7) into the flow injection apparatus. Follow the instrument manufacturer's instructions to store the retention time window for cyanide using the data acquisition software.

12.5 Inject each working standard and the reagent blank from 12.4 into the apparatus and record the amperometric response with the data acquisition system. Plot the response versus the cyanide concentration with a straight line or a quadratic fit curve depending on the instrument and data acquisition system employed. If the calibration model is polynomial, it may be no more than third order. A second order polynomial is recommended. An example of a calibration curve is shown in Fig. 2.

12.6 Prepare a new calibration curve at least once daily.

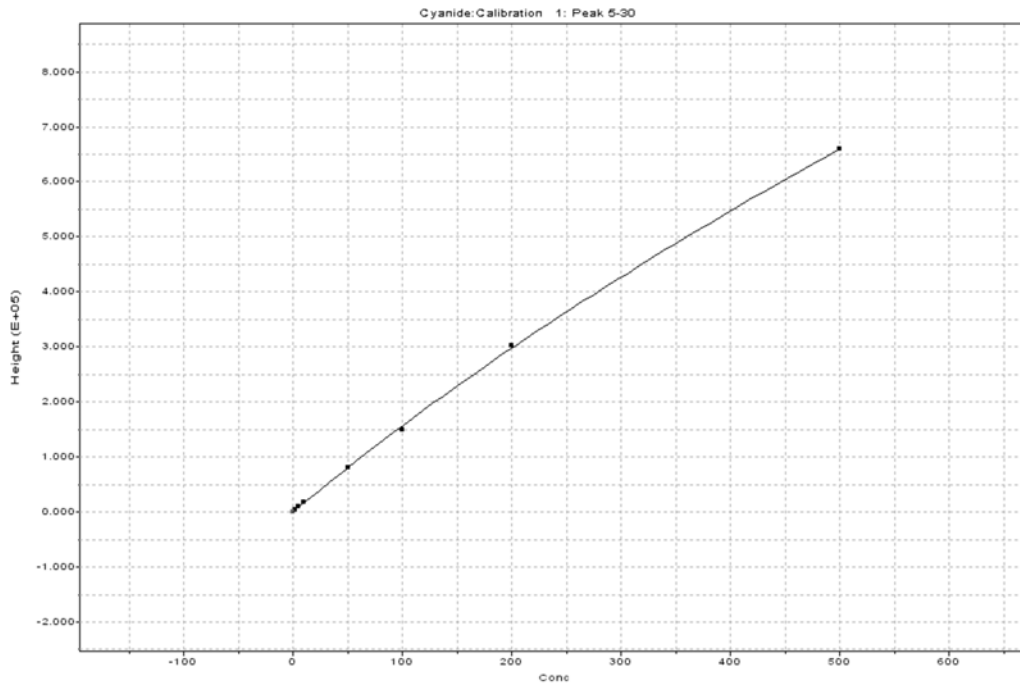

FIG. 2 Example of Calibration Curve

13. Procedure

13.1 Place 10 mL of each sample to be tested in separate polyethylene containers.

13.2 Inject each sample into the flow injection apparatus, and inspect for irregular peak shapes, disturbances, or detector overloads. Dilute and re-run samples if necessary.

14. Data Analysis and Calculations

14.1 Report the cyanide as parts per billion (µg/L) total cyanide using the data acquisition software.

14.2 Multiply the result by any dilution factor and round the test result to three significant figures.

14.3 Some instruments are capable of performing multiple injections in which the mean result for each sample can be reported. In this case, the mean result should be reported.

15. Precision and Bias ⁹

15.1 Based on the results of 8 operators in 8 laboratories, the overall precision and method bias data are shown in Table 4. The precision and bias data were obtained using real wastewater samples during an interlaboratory study equivalent to

⁹ Supporting data is pending being filed at ASTM International Headquarters.

TABLE 2 Quality Control Acceptance Criteria

Parameter	Value (µg/L)	% Recovery	Precision
MDL	1.0		
ML	3.0		
IPR (as Fe II CN)	100	82–118	≤12 % RSD
OPR (as Fe II CN)	100	84–116	NA
OPR (as Fe II CN)	2000	71–128	NA
MS/MSD (as Fe III CN)	50.0	64–136	≤47 % RPD
CCV (as KCN or NaCN)	50.0	90–110	≤10 % RPD
CCV (as KCN or NaCN)	2000	85–115	≤15 % RPD

TABLE 3 Sample Matrices for Interlaboratory Study

Sample	Sample #	Type and Concentration of Spike mg/L	Expected CN mg/L
Drum handling facility (filter effluent)	1	2.00 as [Fe(CN) ₆] ⁻⁴	2.04
POTW (secondary effluent)	2	0.10 as [Fe(CN) ₆] ⁻³	0.100
Petroleum refinery (secondary effluent)	3	2.00 as [Ag(CN) ₂] ⁻ + 2.00 as [Ni(CN) ₄] ⁻²	4.32
Coke plant (secondary effluent)	4	1.00 as [Hg(CN) ₄] ⁻²	3.45
Rolling mill (secondary effluent)	5	0.020 as [Fe(CN) ₆] ⁻⁴	0.020
Metals forming plant (primary effluent)	6	No spike	0.004
Die casting plant (secondary effluent)	7	No spike	0.030
Precious metal operation (reclaim water)	8	1.00 as [Fe(CN) ₆] ⁻⁴ + 20.0 SCN ⁻	1.030
Water treatment plant (filter effluent)	9	No spike	0.007

Practice D2777; data may not apply to all untested matrices. Table 3 lists the matrices, species of cyanide present, and expected values of samples used in the interlaboratory study.

15.2 This method was also evaluated and validated in a single laboratory. In the single lab study, this procedure was found to be suitable for several natural and industrial matrices including treated municipal wastewater (POTW), industrial wastewater, and precious metal operation reclaim water. Recoveries of iron (III) cyanide and iron (II) cyanide ranged from 96 to 110 %. The precision and bias data from the single laboratory study are shown in Table 5.

16. Quality Assurance and Quality Control

16.1 In order to be certain that analytical values obtained using this test method are valid and accurate within the confidence limits of the test, the following QC procedures must be followed when running the test. For a general discussion of quality control and good laboratory practices, see Practice D5847, Guide D3856, and Practice D4210.

16.2 Calibration and Calibration Verification: