



# Standard Test Methods for Strength of Anchors in Concrete and Masonry Elements<sup>1</sup>

This standard is issued under the fixed designation E 488; the number immediately following the designation indicates the year of original adoption or, in the case of revision, the year of last revision. A number in parentheses indicates the year of last reapproval. A superscript epsilon ( $\epsilon$ ) indicates an editorial change since the last revision or reapproval.

*This standard has been approved for use by agencies of the Department of Defense.*

## 1. Scope

1.1 These test methods cover procedures for determining the static, seismic, fatigue and shock, tensile and shear strengths of post-installed and cast-in-place anchorage systems in structural members made of concrete or structural members made of masonry. Only those tests required by the specifying authority need to be performed.

1.2 These test methods are intended for use with such anchorage devices designed to be installed perpendicular to a plane surface of the structural member.

1.3 Whereas combined tension and shear as well as torsion tests are performed under special conditions, such tests are not covered in the methods described herein.

1.4 While individual procedures are given for static, seismic, fatigue and shock testing, nothing herein shall preclude the use of combined testing conditions which incorporate two or more of these types of tests, (such as seismic, fatigue and shock tests in series), since the same equipment is used for each of these tests.

1.5 *This standard does not purport to address all of the safety concerns, if any, associated with its use. It is the responsibility of the user of this standard to establish appropriate safety and health practices and determine the applicability of regulatory limitations prior to use.*

## 2. Referenced Documents

### 2.1 ASTM Standards:

- E 4 Practices for Force Verification of Testing Machines<sup>2</sup>
- E 171 Specification for Standard Atmospheres for Conditioning and Testing Flexible Barrier Materials<sup>3</sup>
- E 468 Practice for Presentation of Constant Amplitude Fatigue Test Results for Metallic Materials<sup>2</sup>
- E 575 Practice for Reporting Data from Structural Tests of Building Constructions, Elements, Connections, and Assemblies<sup>4</sup>

<sup>1</sup> These test methods are under the jurisdiction of ASTM Committee E-6 on Performance of Buildings and are the direct responsibility of Subcommittee E06.13 on Structural Performance of Connections in Building Constructions.

Current edition approved April 10, 1996. Published June 1996. Originally published as E 488 – 76. Last previous edition E 488 – 90.

<sup>2</sup> *Annual Book of ASTM Standards*, Vol 03.01.

<sup>3</sup> *Annual Book of ASTM Standards*, Vol 15.09.

<sup>4</sup> *Annual Book of ASTM Standards*, Vol 04.11.

## 3. Terminology

### 3.1 Definitions of Terms Specific to This Standard:

3.1.1 *adhesive anchor*—a post-installed anchor that derives its holding strength from the chemical compound between the wall of the hole and the anchor rods. The materials used include epoxy, cementitious material, polyester resin, and other similar types.

3.1.2 *anchor spacing*—the distance between anchors measured centerline to centerline, in mm (in.); also, the minimum distance between reaction points of the test frame.

3.1.3 *cast-in-place anchor*—an anchor that is installed prior to the placement of concrete and derives its holding strength from plates, lugs, or other protrusions that are cast into the concrete.

3.1.4 *displacement*—movement of an anchor relative to the structural member. For tension tests, displacement is measured along the axis of the anchor, and for shear tests, displacement is measured perpendicular to the axis of the anchor, in mm (in.).

3.1.5 *edge distance*—side cover distance or the distance from the centerline of an anchor to the nearest edge of a structural member, in mm (in.); also, minimum distance from the centerline to the test frame.

3.1.6 *embedment depth*—distance from the test member surface to the installed end of the anchor, in mm (in.), prior to the setting of the anchor.

3.1.7 *expansion anchor*—a post-installed anchor that derives its holding strength through a mechanically expanded system which exerts forces against the sides of the drilled hole.

3.1.8 *fatigue test*—a laboratory test that applies repeated load cycles to an anchorage system for the purpose of determining the fatigue life or fatigue strength of that system.

3.1.9 *LVDT*—a linear variable differential transformer used for measuring the displacement or movement of an anchor or anchor system.

3.1.10 *post-installed anchor*—an anchor that is installed after the placement and hardening of concrete.

3.1.11 *run-out*—a condition where failure did not occur at a specified number of load cycles in a fatigue test.

3.1.12 *safe working loads*—the allowable or design load obtained by applying factors of safety to the ultimate load of the anchorage device, kN (lbf).

3.1.13 *seismic test*—a laboratory test that applies load

 **E 488**

cycles of varying magnitude and frequency to an anchorage system for the purpose of simulating a seismic event (earthquake).

3.1.14 *shear test*—a test in which an anchor is loaded perpendicular to the axis of the anchor and parallel to the surface of the structural member.

3.1.15 *shock test*—a laboratory test that simulates shock loads on an anchorage system by the application of a short duration external load.

3.1.16 *static test*—a test in which a load is slowly applied to an anchor according to a specified rate such that the anchor receives one loading cycle.

3.1.17 *structural member*—the material in which the anchor is installed and which resists forces from the anchor.

3.1.18 *tensile test*—a test in which an anchor is loaded axially in tension.

3.1.19 *undercut anchor*—a post-installed anchor that derives its holding strength from an expansion of an embedded portion of the anchor into a portion of the hole that is larger in diameter than the portion of the hole between the enlarged section and the surface of the structural member. The enlarged diameter section of the hole is predrilled or enlarged by an expansion process during setting of the anchor.

3.2 *Symbols:*

$h_{ef}$	= effective depth of embedment of an anchor in mm (in.).
$F_s$	= safe working load in kN (lbf).
$h$	= thickness of the structural member in mm (in.).
$h_v$	= anchor embedment depth in mm (in.).
$s$	= anchor spacing in mm (in.) measured centerline to centerline.
$c$	= edge distance in mm (in.) measured from centerline of anchor to edge.
$d$	= nominal anchor diameter in mm (in.).
$\Delta_T$	= uncorrected displacement for tension tests in mm (in.).
$\Delta_S$	= uncorrected displacement for shear tests in mm (in.).
$A_N$ and $B_N$	= instrument readings at a given load in mm (in.).
$A_I$ and $B_I$	= initial instrument readings in mm (in.).
$\Delta_T$	= average displacement at maximum load for tension tests in mm (in.).
$\Delta_S$	= average displacement at maximum load for shear tests in mm (in.).
$n$	= number of test samples.
$N_T$	= total number of load cycles in tension fatigue test.
$N_S$	= total number of load cycles in shear fatigue test.
$\bar{N}_T$	= average number of load cycles in tension fatigue test.
$\bar{N}_S$	= average number of load cycles in shear fatigue test.
$\Delta_{FT}$	= displacement of anchor occurring at maximum load for tension fatigue test mm (in.).

$\Delta_{FS}$	= displacement of anchor occurring at maximum load for shear fatigue test mm (in.).
$A_{fu}$ and $B_{fu}$	= maximum displacement instrument readings for fatigue tests mm (in.).
$A_{fi}$ and $B_{fi}$	= initial displacement instrument readings for fatigue tests mm (in.).
$\bar{\Delta}_{FT}$	= average maximum displacement for tension fatigue tests mm (in.).
$\bar{\Delta}_{FS}$	= average maximum displacement for shear fatigue tests mm (in.).

**4. Significance and Use**

4.1 These test methods are intended to provide data from which applicable design data and specifications are derivable for a given anchorage device used in a structural member of concrete, masonry and related products and for qualifying anchors or anchorage systems.

4.2 The test methods shall be followed to ensure reproducibility of the test data.

**5. Apparatus**

5.1 *Equipment:*

5.1.1 *Laboratory*—Suitable equipment shall be used to perform tests to generate data required to publish load tables or to obtain listings from approval agencies, building officials, etc. Calibrated electronic load and displacement measuring devices which meet the sampling rate of loading specified herein shall be used. The equipment shall be capable of measuring the forces to an accuracy within  $\pm 1\%$  of the anticipated ultimate load, when calibrated in accordance with Practices E 4. The load and displacement measuring devices shall be capable of providing data points at least once per second in order to produce continuous load versus displacement curves. A minimum of 120 data points per instrument shall be obtained and recorded for each individual test. The readings shall be obtained prior to reaching peak load. The instruments shall be positioned to measure the vertical movement of the anchor with respect to points on the structural member in such a way that the instrument is not influenced during the test by deflection or failure of the anchor or structural member. The testing device shall be of sufficient capacity to prevent yielding of its various components and shall ensure that the applied tension loads remain parallel to the axes of the anchors and that the applied shear loads remain parallel to the surface of the structural member during testing.

5.1.2 *Field Tests*—Suitable equipment shall be used to perform tests required to verify correct installation or provide proof loads on anchors installed at a specific job site. Calibrated load cells which meet the specified rate of loading given herein shall be used. The equipment shall be capable of measuring the forces to an accuracy within  $\pm 2\%$  of the applied load, when calibrated in accordance with Practices E 4. For field tests which require displacement measurements, use either manually read dial gages or electronic load and displacement measuring devices, provided they are capable of generating a minimum of 50 data points prior to reaching peak load. For field tests requiring displacement measurements, the instrument(s) shall be positioned to measure the vertical movement of the anchor with respect to points on the structural

**ASTM E 488**

member in such a way that the instrument is not influenced during the test by deflection or failure of the anchor or structural member. The testing device shall be of sufficient capacity to prevent yielding of its various components and shall ensure that the applied tension loads remain parallel to the axes of the anchors and that the applied shear loads remain parallel to the surface of the structural member during testing.

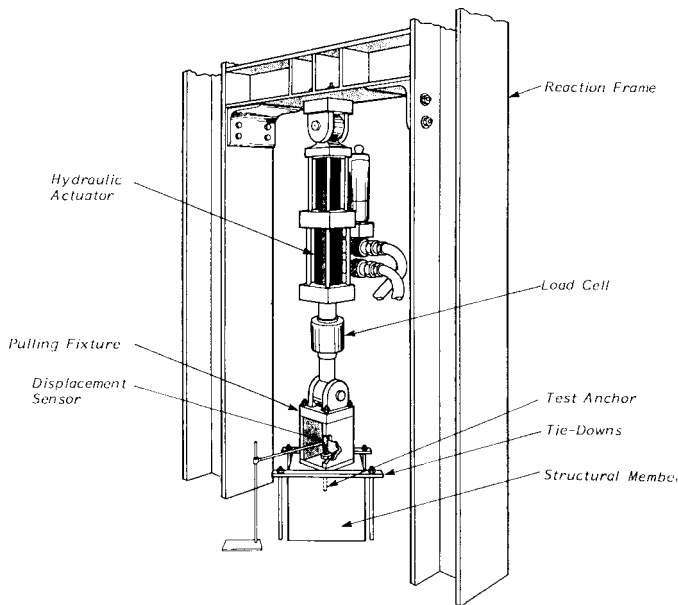
5.2 *Tension Test*—Examples of suitable systems for applying tension pull-out forces are shown in Figs. 1 and 2 in which a single anchor specimen is shown. The test system support shall be of sufficient size to prevent failure of the surrounding structural member. The loading rod shall be of such size to develop the ultimate strength of the anchorage hardware with minimal elastic elongation and shall be attached to the anchorage system by means of a connector that will minimize the direct transfer of bending stress through the connection.

5.3 *Shear Test*—Examples of suitable systems for applying shear forces are shown in Figs. 3 and 4 in which a single anchor specimen is shown. The components of the test fixture shall be of sufficient size and strength to prevent their yielding during ultimate capacity tests on the anchorage system.

5.4 *Loading Plate*—The thickness of the loading plate in the immediate vicinity of the test anchor shall be equal to the nominal bolt diameter to be tested,  $\pm 1.5$  mm ( $\pm 1/16$  in.), representative of a specific application.

5.4.1 The hole in the loading plate shall have a diameter 1.5 mm  $\pm$  0.75 mm (0.06 mm  $\pm$  0.03 in.) greater than the test anchor. The initial shape of the hole in the loading plate shall correspond to that of the anchor cross section and shall be maintained throughout all tests. Worn or deformed holes shall be repaired. Insert sleeves of the required diameter shall be periodically installed in the loading plate to meet these requirements.

5.4.2 For shear testing, the contact area between the loading plate through which the anchor is installed and the structural member shall be as given in Table 1, unless otherwise specified. The edges of the shear loading fixture shall be



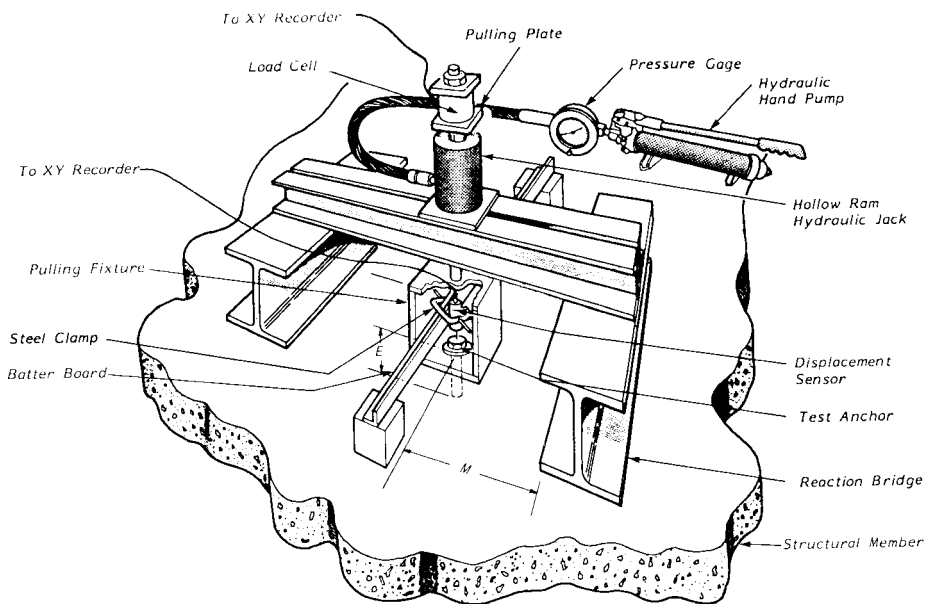
**FIG. 2 Typical Seismic Tension Test Arrangement**

chamfered or have a radius to prevent digging in of the loading plate.

5.5 *Anchor Displacement Measurement*— For anchor tests that require displacement measurements, the displacement measurements shall be made using LVDT device(s) or equivalent which provide continuous readings with an accuracy of at least 0.025 mm (0.001 in.). Dial gages having an accuracy of 0.025 mm (0.001 in.) are permitted in field testing or for general tests where precise displacement measurements are not required.

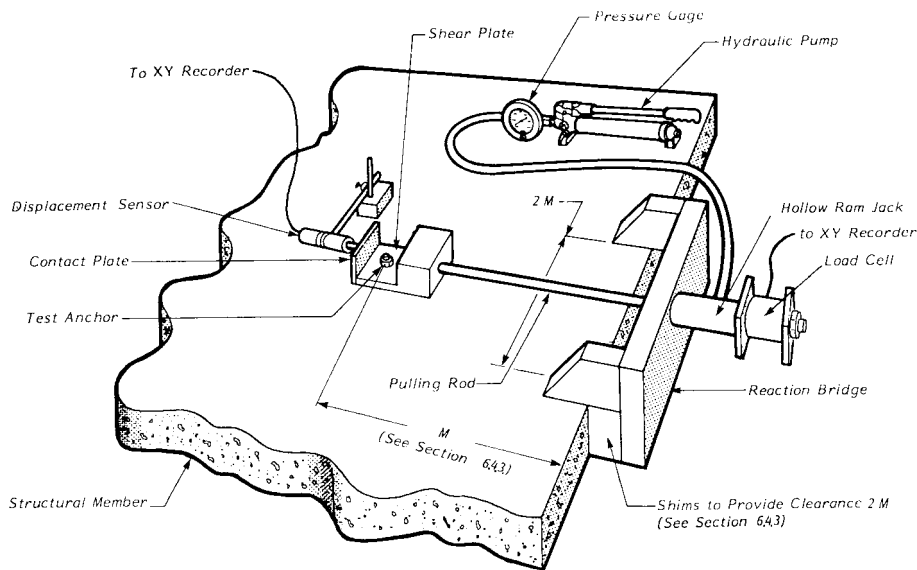
5.5.1 *Tension Test:*

5.5.1.1 *Single Anchor*—The displacement measuring device(s) shall be positioned to measure the vertical movement of the anchors with respect to points on the structural member in such a way that the device is not influenced during the test by

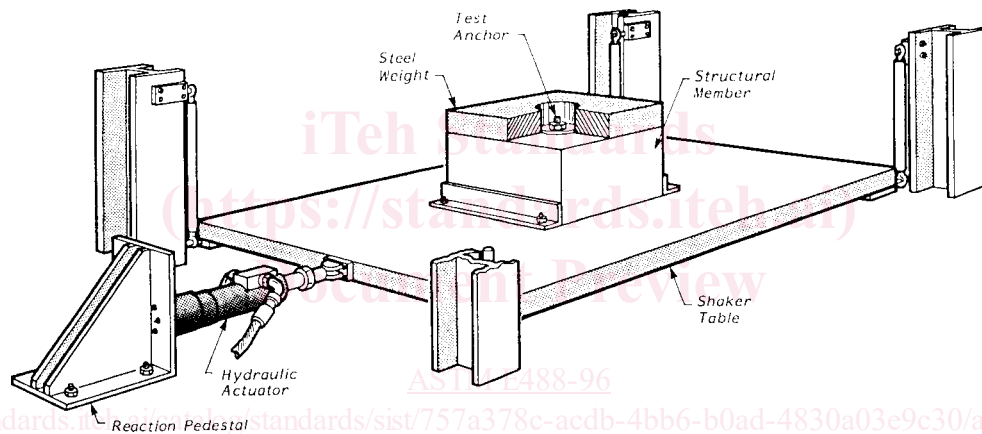


**FIG. 1 Typical Static Tension Test Arrangement**

**ASTM E 488**



**FIG. 3 Typical Method of Applying Shear Loads to Anchors Attached to Structural Members—Direct Loading Method**



**FIG. 4 Typical Seismic Shear Test Arrangement—Indirect Loading Method**

**TABLE 1 Shear Loading Plate Bearing Area as a Function of Anchor Diameter**

Anchor Diameter, mm (in.)	Shear Loading Plate Contact Area, cm <sup>2</sup> (in. <sup>2</sup> )
<10 (<3/8)	50–80 (8.00–12.40)
10–<16 (3/8 –<5/8)	80.01–120 (12.41–18.60)
16–<22 (5/8 –<7/8)	120.01–160 (18.61–24.80)
22–<51 (7/8 –<2)	160.01–260 (24.81–40.30)
>51 (>2)	260.1–400 (40.31–62.00)

deflection or failure of the anchor or structural member.

5.5.1.2 *Group of Anchors*—Displacement measurements shall be made on all anchors or group of anchors tested simultaneously except that only one set of instruments needs to be used for a group of anchors tested as a closely spaced cluster. Displacement measurements as described in 5.5 include components of deformation not directly associated with displacement of the anchor relative to the structural member. Include components of deformation such as elastic elongation of the loading rod anchor stem, deformation of the loading plate, sleeves, shims, attachment hardware, and local structural member material. Deduct all of the elongations from these

sources from the total displacement measurements by using supplementary measuring devices or calibration test data for the installed test set-up with rigid specimen replacing the anchor to be tested. The displacement to be used for the evaluation of the findings is the average displacement indicated by both instruments mounted symmetrically equidistant from the centroid of the cluster as shown in Fig. 5.

5.5.2 *Shear Test*—The displacement measuring device(s) shall be positioned to measure displacement in the direction of the applied load. The device shall be placed on the structural member to allow the sensing element to bear perpendicularly on the anchor or on a contact plate located on the loading plate as shown in Fig. 3 or other method which prevents extraneous deflections. For tests on clusters of anchors, the instrument shall lie on a plane through the axis of the shear loading rod or plate. An extension of the axis of the shear loading rod or plate shall pass through the centric axis of the cluster of anchors.

**6. Test Specimens**

6.1 *Anchorage System*—The anchorage system shall be representative of the type and lot to be used in field construction and shall include all accessory hardware normally required