**Pneumatic fluid power — Push-in
connectors for thermoplastic tubes**

*Transmissions pneumatiques — Raccords instantanés pour tubes
thermoplastiques*

iTeh Standards
(<https://standards.iteh.ai>)
Document Preview

[ISO 14743:2020](https://standards.iteh.ai/catalog/standards/iso/eacc6889-3f56-4a46-a6ac-b0d54152398a/iso-14743-2020)

<https://standards.iteh.ai/catalog/standards/iso/eacc6889-3f56-4a46-a6ac-b0d54152398a/iso-14743-2020>



iTeh Standards
(<https://standards.iteh.ai>)
Document Preview

[ISO 14743:2020](https://standards.iteh.ai/catalog/standards/iso/eacc6889-3f56-4a46-a6ac-b0d54152398a/iso-14743-2020)

<https://standards.iteh.ai/catalog/standards/iso/eacc6889-3f56-4a46-a6ac-b0d54152398a/iso-14743-2020>



COPYRIGHT PROTECTED DOCUMENT

© ISO 2020

All rights reserved. Unless otherwise specified, or required in the context of its implementation, no part of this publication may be reproduced or utilized otherwise in any form or by any means, electronic or mechanical, including photocopying, or posting on the internet or an intranet, without prior written permission. Permission can be requested from either ISO at the address below or ISO's member body in the country of the requester.

ISO copyright office
CP 401 • Ch. de Blandonnet 8
CH-1214 Vernier, Geneva
Phone: +41 22 749 01 11
Fax: +41 22 749 09 47
Email: copyright@iso.org
Website: www.iso.org

Published in Switzerland

Contents

| | Page |
|--|-----------|
| Foreword | v |
| Introduction | vi |
| 1 Scope | 1 |
| 2 Normative references | 1 |
| 3 Terms and definitions | 1 |
| 4 Working conditions | 1 |
| 5 Features | 2 |
| 6 OD of tube | 2 |
| 7 Design | 2 |
| 8 Marking | 12 |
| 9 Performance requirements and testing | 12 |
| 9.1 General..... | 12 |
| 9.2 Test samples..... | 12 |
| 9.3 Tensile test..... | 13 |
| 9.3.1 Procedure..... | 13 |
| 9.3.2 Pass/fail criteria..... | 13 |
| 9.4 Pressure at maximum temperature test (for PA tubing only)..... | 13 |
| 9.4.1 Description..... | 13 |
| 9.4.2 Apparatus..... | 13 |
| 9.4.3 Procedure..... | 14 |
| 9.4.4 Pass/fail criteria..... | 14 |
| 9.5 Proof and burst pressure test (for PA tubing only)..... | 14 |
| 9.5.1 Description..... | 14 |
| 9.5.2 Apparatus..... | 14 |
| 9.5.3 Procedure..... | 14 |
| 9.5.4 Pass/fail criteria..... | 15 |
| 9.6 Connecting force test..... | 15 |
| 9.6.1 Apparatus..... | 15 |
| 9.6.2 Procedure..... | 15 |
| 9.6.3 Pass/fail criteria..... | 15 |
| 9.7 Disconnecting force test..... | 16 |
| 9.7.1 Apparatus..... | 16 |
| 9.7.2 Procedure..... | 16 |
| 9.7.3 Pass/fail criteria..... | 16 |
| 9.8 Leakage test (to be performed before disconnecting)..... | 16 |
| 9.8.1 Description..... | 16 |
| 9.8.2 Apparatus..... | 16 |
| 9.8.3 Procedure..... | 17 |
| 9.8.4 Pass/fail criteria..... | 19 |
| 9.9 Cyclic endurance (impulse) test with vibration (for PA tubing only)..... | 19 |
| 9.9.1 Description..... | 19 |
| 9.9.2 Apparatus..... | 19 |
| 9.9.3 Procedure..... | 19 |
| 9.9.4 Pass/fail criteria..... | 21 |
| 10 Designation | 21 |
| 11 Identification statement (reference to this document)..... | 23 |
| Annex A (normative) PA tubes for testing | 24 |
| Annex B (normative) PU tubes for testing | 27 |

iTeh Standards
(<https://standards.itih.ai>)
Document Preview

[ISO 14743:2020](https://standards.itih.ai/catalog/standards/iso/eacc6889-3f56-4a46-a6ac-b0d54152398a/iso-14743-2020)

<https://standards.itih.ai/catalog/standards/iso/eacc6889-3f56-4a46-a6ac-b0d54152398a/iso-14743-2020>

Foreword

ISO (the International Organization for Standardization) is a worldwide federation of national standards bodies (ISO member bodies). The work of preparing International Standards is normally carried out through ISO technical committees. Each member body interested in a subject for which a technical committee has been established has the right to be represented on that committee. International organizations, governmental and non-governmental, in liaison with ISO, also take part in the work. ISO collaborates closely with the International Electrotechnical Commission (IEC) on all matters of electrotechnical standardization.

The procedures used to develop this document and those intended for its further maintenance are described in the ISO/IEC Directives, Part 1. In particular, the different approval criteria needed for the different types of ISO documents should be noted. This document was drafted in accordance with the editorial rules of the ISO/IEC Directives, Part 2 (see www.iso.org/directives).

Attention is drawn to the possibility that some of the elements of this document may be the subject of patent rights. ISO shall not be held responsible for identifying any or all such patent rights. Details of any patent rights identified during the development of the document will be in the Introduction and/or on the ISO list of patent declarations received (see www.iso.org/patents).

Any trade name used in this document is information given for the convenience of users and does not constitute an endorsement.

For an explanation of the voluntary nature of standards, the meaning of ISO specific terms and expressions related to conformity assessment, as well as information about ISO's adherence to the World Trade Organization (WTO) principles in the Technical Barriers to Trade (TBT) see www.iso.org/iso/foreword.html.

This document was prepared by Technical Committee ISO/TC 131, *Fluid power systems*, Subcommittee SC 4, *Connectors and similar products and components*.

This second edition cancels and replaces the first edition (ISO 14743:2004), which has been technically revised. The main changes compared to the previous edition are as follows:

- new fitting size including inch dimensions has been added;
- new normative references have been added;
- updates on leakages performances and precisions have been added for cyclic endurance with vibration.

Any feedback or questions on this document should be directed to the user's national standards body. A complete listing of these bodies can be found at www.iso.org/members.html.

Introduction

In pneumatic fluid power systems, power is transmitted and controlled through air under pressure within a circuit.

Components are connected through their ports by means of connectors (fittings) and conductors.

iTeh Standards
(<https://standards.itih.ai>)
Document Preview

[ISO 14743:2020](https://standards.itih.ai/catalog/standards/iso/eacc6889-3f56-4a46-a6ac-b0d54152398a/iso-14743-2020)

<https://standards.itih.ai/catalog/standards/iso/eacc6889-3f56-4a46-a6ac-b0d54152398a/iso-14743-2020>

Pneumatic fluid power — Push-in connectors for thermoplastic tubes

1 Scope

This document specifies the general requirements and test methods for the design and performance of push-in connectors for use with thermoplastic tubes with outside diameters (OD) from 3 mm to 16 mm including dimensions in inches.

This document is intended to establish uniform methods of testing complete push-in connector assemblies as used in pneumatic fluid power applications. It is not applicable to air braking systems.

2 Normative references

The following documents are referred to in the text in such a way that some or all of their content constitutes requirements of this document. For dated references, only the edition cited applies. For undated references, the latest edition of the referenced document (including any amendments) applies.

ISO 7-1, *Pipe threads where pressure-tight joints are made on the threads — Part 1: Dimensions, tolerances and designation*

ISO 4759-1, *Tolerances for fasteners — Part 1: Bolts, screws, studs and nuts — Product grades A, B and C*

ISO 5598, *Fluid power systems and components — Vocabulary*

ISO 8573-1:2010, *Compressed air — Part 1: Contaminants and purity classes*

ISO 10619-1, *Rubber and plastics hoses and tubing — Measurement of flexibility and stiffness — Part 1: Bending tests at ambient temperature*

ISO 16030, *Pneumatic fluid power — Connections — Ports and stud ends*

ANSI/ASME B1.1, *Unified Inch Screw Threads, (UN and UNR Thread Form)*

ANSI/ASME B1.20.1, *Pipe Threads, General Purpose, Inch*

ANSI/ASME B1.20.3, *Dryseal Pipe Threads (Inch)*

3 Terms and definitions

For the purposes of this document, the terms and definitions given in ISO 5598 apply.

ISO and IEC maintain terminological databases for use in standardization at the following addresses:

- IEC Electropedia: available at <http://www.electropedia.org/>
- ISO Online browsing platform: available at <https://www.iso.org/obp>

4 Working conditions

Push-in connectors shall provide connections from $-0,09$ MPa [$-0,9$ bar¹⁾] to a working pressure of 1,6 MPa (16 bar) when used at temperatures between -20 °C and $+80$ °C.

1) 1 bar = 0,1 MPa = 105 Pa; 1 MPa = 1 N/mm²

The connector assembly shall meet the performance requirements given in [Clause 9](#) with tubes specified in [Annex A](#) and [Annex B](#).

When tubing with a lower rated pressure is used, the maximum working pressure of the tube and connector assembly shall be that of the tubing.

In road vehicles, it is necessary to exercise special care to ensure that these connectors are never used in an air braking system.

5 Features

Design is optional to the manufacturer. Two examples are shown in [Figure 1](#).

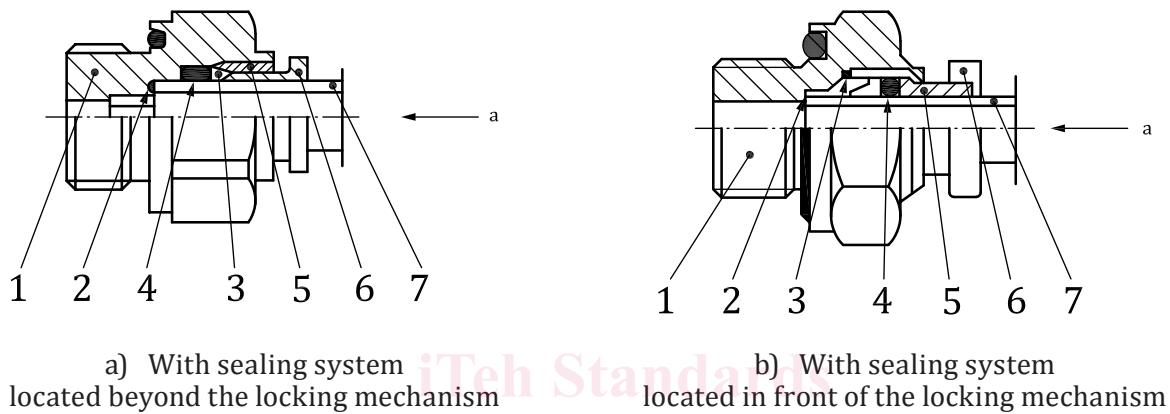

Key

- | | | | |
|---|-------------------|---|-----------------------------|
| 1 | body | 5 | releasing sleeve |
| 2 | tube stop | 6 | removable button (optional) |
| 3 | grab ring of tube | 7 | tube |
| 4 | sealing of tube | a | Entry of the tube. |

<https://standards.iteh.ai/catalog/standards/iso/eacc6889-3f56-4a46-a6ac-b0d54152398a/iso-14743-2020>

Figure 1 — Examples of design and description of the features of push-in connectors for use with thermoplastic tubes

6 OD of tube

The OD of the tube shall be chosen from the following range of sizes:

3 mm, 1/8 in (3,17 mm), 4 mm (5/32 in), 6 mm, 1/4 in (6,35 mm), 8 mm (5/16 in), 10 mm, 3/8 in (9,52 mm), 12 mm, 1/2 in (12,7 mm), 14 mm, and 16 mm (5/8 in).

7 Design

7.1 Push-in connector dimensions shown in [Figures 2](#) to [7](#) shall conform to the dimensions given in [Tables 1](#) to [7](#).

7.2 Hexagon tolerances across flats shall be in accordance with ISO 4759-1, Grade C. The minimum hexagon across-corner turn diameter of 1,092 times the normal across flats dimension shall be used.

7.3 For connectors with the thread M and G, thread and stud end shall be in accordance with ISO 16030.

For connector with the thread R, thread and stud end shall be in accordance with ISO 7-1.

For connector with NPT thread, thread and stud end shall be in accordance with ANSI/ASME B1.20.1 and ANSI/ASME B1.20.3.

For connector with UNF thread, thread and stud end shall be in accordance with ANSI/ASME B1.1.

7.4 Details of contour shall be at the option of the manufacturer if the dimensions given in the Tables are maintained.

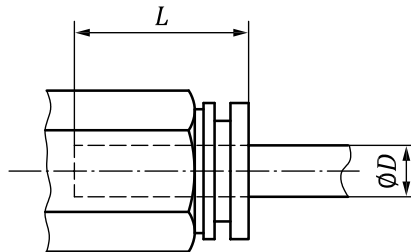

Key

D tube OD

L maximum insertion depth

Figure 2 — Tube insertion depth

Table 1 — Maximum tube insertion depth

| Tube OD D | | Maximum insertion depth L | |
|----------------|----|--------------------------------|--|
| in (mm) | mm | mm | |
| 1/8 (3,17) | 3 | 16 | |
| 5/32 (4) | 4 | 18 | |
| 1/4 (6,35) | 6 | 19 | |
| 5/16 (8) | 8 | 20 | |
| 3/8 (9,52) | 10 | 24 | |
| 1/2 (12,7) | 12 | 33 | |
| | 14 | 33 | |
| 5/8 (16) | 16 | 35 | |

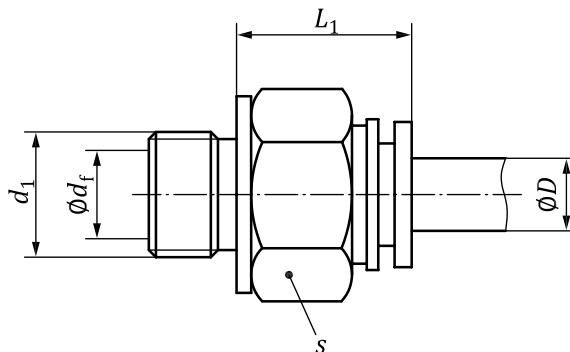

Key

D tube OD

d_1 thread outside diameter

s hexagon socket dimension

L_1 Stud adaptor height

d_f flow diameter

Figure 3 — Stud adaptor (SDS)

Table 2 — SDS dimensions for tube OD in millimetres

Dimensions in millimetres

| Tube OD <i>D</i> | <i>d</i> ₁ | <i>L</i> ₁ max. | <i>s</i> ^a max. | Flow diameter <i>d</i> _f min. |
|---------------------|------------------------------|-------------------------------|-------------------------------|--|
| 3 | M3 | 17 | 10 | 1,2 |
| | M5 | 17 | 10 | 1,8 |
| 4 | M3 | 22 | 12 | 1,2 |
| | M5 | 22 | 12 | 2 |
| | M7 | 22 | 12 | 2,5 |
| | G1/8, R1/8, 1/8NPT | 22 | 14 | 2,5 |
| | G1/4, R1/4, 1/4NPT | 22 | 19 | 2,5 |
| | R3/8 | 22 | 22 | 3 |
| 6 | M5 | 23 | 12 | 2,5 |
| | M7 | 23 | 14 | 3 |
| | M10 | 23 | 15 | 4 |
| | M12 | 23 | 17 | 4 |
| | G1/8, R1/8, 1/8NPT | 23 | 14 | 4 |
| | G1/4, R1/4, 1/4NPT | 23 | 19 | 4 |
| | G3/8, R3/8 | 23 | 22 | 4 |
| | G1/2, R1/2 | 23 | 26 | 4 |
| 8 | M10, M12, G1/8, R1/8, 1/8NPT | 24 | 17 | 5 |
| | G1/4, R1/4, 1/4NPT | 24 | 19 | 6 |
| | G3/8, R3/8, 3/8NPT | 24 | 22 | 6 |
| | G1/2, R1/2 | 24 | 26 | 6 |
| 10 | G1/4 | 27 | 19 | 7 |
| | G3/8, R3/8, 3/8NPT | 27 | 22 | 8 |
| | G1/2 | 27 | 26 | 8 |
| | R1/8 | 27 | 19 | 5 |
| | R1/4, 1/4NPT | 27 | 22 | 7 |
| | R1/2, 1/2NPT | 27 | 26 | 8 |
| 12 | G1/4, R1/4 | 30 | 22 | 7 |
| | G3/8, R3/8, 3/8NPT | 30 | 22 | 9 |
| | G1/2, 1/2NPT | 30 | 26 | 10 |
| | R 1/2 | 30 | 26 | 9 |
| 14 | G3/8, R3/8 | 32 | 25 | 9 |
| | G1/2 | 32 | 26 | 11 |
| | R 1/2 | 32 | 26 | 10 |
| 16 | G3/8, R3/8, 3/8NPT | 34 | 30 | 9 |
| | G1/2, R1/2, 1/2NPT | 34 | 30 | 12 |

^a Hexagon socket or OD at the choice of the manufacturer.

Table 3 — SDS dimensions for tube OD in inches

| Tube OD D in | d_1 mm | L_1 mm max. | s^a mm max. | Flow diameter d_f mm min. |
|----------------------|----------------------------|---------------------|---------------------|--------------------------------------|
| 1/8 | R1/8, 1/16NPT, 1/8NPT | 18 | 14 | 1,8 |
| | 1/4 NPT | 18 | 19 | 1,8 |
| | 10-32 UNF | 18 | 13 | 1,8 |
| 5/32 | R1/8, 1/8NPT | 22 | 14 | 2,5 |
| | R1/4, 1/4NPT | 22 | 20 | 2,5 |
| | 10-32 UNF | 22 | 13 | 2 |
| 1/4 | R1/8, 1/8NPT | 23 | 15 | 4 |
| | R1/4, 1/4NPT | 23 | 19 | 4 |
| | 1/16 NPT | 23 | 14 | 3 |
| | 3/8 NPT | 23 | 22 | 4 |
| | 10-32 UNF | 23 | 14 | 2 |
| | M5 | 23 | 12 | 2,5 |
| | M7 | 23 | 14 | 4 |
| 5/16 | R1/8, 1/8NPT | 25 | 17 | 5 |
| | R1/4, 1/4NPT | 25 | 19 | 6 |
| | R3/8, 3/8NPT | 25 | 22 | 6 |
| | R 1/2 | 25 | 26 | 6 |
| 3/8 | R1/4, 1/4NPT | 28 | 19 | 7 |
| | R3/8, 3/8NPT | 28 | 22 | 7 |
| | R1/2, 1/2NPT | 28 | 26 | 7 |
| | 1/8 NPT | 28 | 19 | 4 |
| 1/2 | R1/4, 1/4NPT | 30 | 26 | 6 |
| | R3/8, R1/2, 3/8NPT, 1/2NPT | 30 | 26 | 7 |
| 5/8 | G3/8, R3/8, 3/8NPT | 34 | 30 | 9 |
| | G1/2, R1/2, 1/2NPT | 34 | 30 | 12 |

^a Hexagon socket or OD at the choice of the manufacturer.