



Designation: E2558-08

Standard Test Method for Designation: E2558 – 09

Standard Test Method for Determining Particulate Matter Emissions from Fires in Low Mass Wood-Burning Fireplaces¹

This standard is issued under the fixed designation E2558; the number immediately following the designation indicates the year of original adoption or, in the case of revision, the year of last revision. A number in parentheses indicates the year of last reapproval. A superscript epsilon (ϵ) indicates an editorial change since the last revision or reapproval.

1. Scope

1.1 This test method covers the fueling and operating protocol for determining particulate matter emissions from wood fires in low mass wood-burning fireplaces.

~~1.2 The values stated in SI units are to be regarded as the standard. The values given in parentheses are for information only.~~

1.2 The values stated in SI units are to be regarded as standard. The values given in parentheses are mathematical conversions to inch-pound units that are provided for information only and are not considered standard.

1.3 *This standard does not purport to address all of the safety concerns, if any, associated with its use. It is the responsibility of the user of this standard to establish appropriate safety and health practices and determine the applicability of regulatory limitations prior to use.*

2. Referenced Documents

2.1 *ASTM Standards:*²

E631 [Terminology of Building Constructions](#)

E2515 [Test Method for Determination of Particulate Matter Emissions Collected by a Dilution Tunnel](#)

3. Terminology

3.1 *Definitions*—Terms used in this test method are defined in Terminology E631.

3.2 *Definitions of Terms Specific to This Standard:*

3.2.1 *base of fireplace, n*—the lowest part of the fireplace assembly that would normally be in contact with the floor of the dwelling or structure in which it is installed.

~~3.2.2~~ 3.2.2 *Douglas fir, n*—untreated, standard, or better grade Douglas fir lumber with agency grade stamp: D. Fir or Douglas Fir.

~~3.2.2~~

3.2.3 *firebox, n*—the volume within the fireplace where logs are burned.

~~3.2.3~~

3.2.4 *first fuel crib, n*—the first fuel load (including fuel pieces and spacers to create air spaces) placed on the residual fuel from the kindling brands. The specific configuration is described in ~~9.3.4.4~~ 3.5.3.

~~3.2.4~~

3.2.5 *fuel piece, n*— 2×4 or 4×4 wood pieces used to construct fuel cribs and referring to the nominal width and depth dimensions for commonly available dimensional lumber. The actual dimensions are 38×89 mm ($1\frac{1}{2} \times 3\frac{1}{2}$ in.) and 89×89 mm ($3\frac{1}{2} \times 3\frac{1}{2}$ in.).

~~3.2.5~~ 3.2.6 *grate, n*—any device included with the fireplace or specified by the fireplace manufacturer for the purpose of elevating the fuel load above the hearth or for constraining fuel pieces from falling outside the intended burning area, or both. This includes basket grates and andirons.

~~3.2.6~~

¹ This test method is under the jurisdiction of ASTM Committee E06 on Performance of Buildings and is the direct responsibility of Subcommittee E06.54 on Solid Fuel Burning Appliances.

Current edition approved April 1, 2008. Published May 2008. Originally approved in 2007. Last previous edition approved in 2007 as E2558-07¹. DOI: 10.1520/E2558-08.

Current edition approved Nov. 1, 2009. Published April 2010. Originally approved in 2007. Last previous edition approved in 2008 as E2558-08. DOI: 10.1520/E2558-09.

² For referenced ASTM standards, visit the ASTM website, www.astm.org, or contact ASTM Customer Service at service@astm.org. For *Annual Book of ASTM Standards* volume information, refer to the standard's Document Summary page on the ASTM website.

3.2.7 *hearth, n*—the footprint of the fireplace firebox.

3.2.7

3.2.8 *kindling brands, n*—the initial fuel load or loads placed above crumpled newspaper to initiate combustion in the fireplace and to establish a charcoal bed that will become the ignition source for subsequent fuel loads. These are comprised of fuel strips separated by air spaces. The specific configuration is described in 9.3.4.

3.2.8

3.2.9 *low mass fireplace, n*—any fireplace and attached chimney that can be weighed (including the weight of the test fuel) on a platform scale that meets the requirements as specified in 7.3 and 8.2.

3.2.9

3.2.10 *nominal fuel length, n*—the Nominal Fuel Length (NFL) is one of five incremental nominal fuel piece lengths that simulates real-world firewood five piece lengths. These lengths are 406 mm (16 in.), 457 mm (18 in.), 508 mm (20 in.), 559 mm (22 in.), and 610 mm (24 in.). The NFL is used for both the kindling brands and fuel cribs.

3.2.10

3.2.11 *particulate matter (PM), n*—all gas-borne matter resulting from combustion of solid fuel, as specified in this test method, which is collected in accordance with Test Method E2515.

3.2.11

3.2.12 *second fuel crib, n*—the second fuel load (including fuel pieces and spacers to create air spaces) placed on the residual fuel from the first fuel crib. The specific configuration is described in 9.3.4.59.3.5.2.

3.2.12

3.2.13 *spacers, n*—wood pieces used to hold individual fuel pieces together when constructing the three fuel cribs. Their function is to provide reproducible fuel crib geometry and air spaces between fuel pieces, as well as to hold the fuel cribs together (with nails).

3.2.13

3.2.14 *standardized fuel retainer, n*—any fireplace that doesn't include or specify a grate as defined in 3.2.5–3.2.6 shall use a standardized fuel retainer during testing. These retainers shall include vertical fuel retainer bars that are made from 19 × 19 mm (0.75 × 0.75 in.) steel square bar or 19 mm (0.75 in.) diameter round steel bar and shall be 200 ± 50 mm (8 ± 2 in.) high. They shall be attached to a steel plate that projects toward the front of the fireplace and shall not interfere with any fireplace function. They shall be spaced so they are 300 ± 13 mm (12 ± ½ in.) apart. Their purpose is to prevent fuel from rolling or falling forward during testing, thus helping to prevent an aborted test. (See Fig. 1.)

3.2.14

3.2.15 *test facility, n*—the area in which the tested fireplace is installed, operated, and sampled for emissions.

3.2.15

3.2.16 *third fuel crib, n*—the third and final fuel load (including fuel pieces and spacers to create air spaces) placed on the residual fuel from the second fuel crib. The specific configuration is described in 9.3.4.69.3.5.3.

<https://standards.iteh.ai/catalog/standards/sist/e50eb5b3-53e3-4f12-9bc2-86885ccea6bd2/astm-e2558-09>

4. Summary of Test Method

4.1 This test method is used in conjunction with Test Method E2515. The fireplace under evaluation is fueled with kindling and cribs in a way that simulates fireplace operation in the home. An algorithm that uses the specific configuration of the test fireplace, including hearth and grate dimensions, is used to determine the kindling and fuel crib geometry and dimensions. Kindling brands are placed in the fireplace above crumpled newspaper and ignited. When the kindling brands have burned to a certain point, the first fuel crib is placed on the remains of the kindling. When the first crib is substantially burned, the remaining material is adjusted as needed to form a base for the second crib. This process is repeated again before addition of the third crib. The third crib is allowed to burn until all flaming from volatile material in the fuel ceases, at which point the test is terminated. Burn rate is

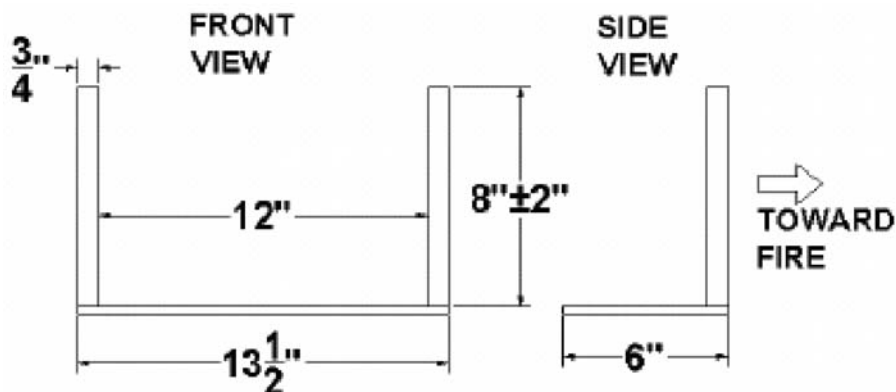

FIG. 1 Example, Standardized Fuel Retainer

determined based on the amount of fuel added less the amount remaining at the end of the test divided by the length of test and corrected to a dry fuel basis. Particulate sampling begins at the time of ignition of the newspaper and stops when the test terminates. The total particulate emissions are determined over the test period. The particulate emissions factor is then determined from the total emissions and the total amount of fuel burned and is reported in grams of particulate per dry kilogram of fuel or grams of particulate per hour.

4.2 If the test fireplace includes standard (or offers optional) components that affect particulate emission performance and that have more than one operating position or condition allowed in the owner's manual that accompanies the fireplace, separate emissions tests may be required for each of the various positions or conditions that are allowed in the manual. This might include things like door open and door closed operation, for example. (See 9.4.14-9.4.16.)

5. Significance and Use

5.1 This test method is used for determining emission factors and emission rates for low mass wood-burning fireplaces.

5.1.1 The emission factor is useful for determining emission performance during product development.

5.1.2 The emission factor is useful for the air quality regulatory community for determining compliance with emission performance limits.

5.1.3 The emission rate may be useful for the air quality regulatory community for determining impacts on air quality from fireplaces, but must be used with caution as use patterns must be factored into any prediction of atmospheric particulate matter impacts from fireplaces based on results from this method.

5.2 The reporting units are grams of particulate per kilogram of dry fuel and grams of particulate per hour.

5.2.1 Appropriate reporting units for comparing emissions from non-heating appliances: g/kg.

5.2.2 Appropriate reporting units for predicting atmospheric emission impacts only if hours of fireplace use are factored in: g/h.

6. Safety

6.1 *Disclaimer*—This test method may involve hazardous materials, operations, and equipment. This test method may not address all of the safety problems associated with its use. It is the responsibility of the user of this test method to establish appropriate safety and health practices and to determine the applicability of regulatory limitations prior to performing this test method.

7. Equipment and Supplies

7.1 *Wood Moisture Meter*—Calibrated electrical resistance meter capable of measuring test fuel moisture to within 1 % moisture content. Must meet the calibration requirements specified in 8.1.

7.2 *Test Fuel Scale*—A scale capable of weighing test fuel to within 0.005 kg (0.01 lb). Must meet the calibration requirements specified in 8.3.

7.3 *Platform Scale*—A scale capable of weighing the test fireplace and attached chimney, including the weight of the test fuel, to within 0.05 kg (0.1 lb). Must meet the calibration requirements specified in 8.2.

7.4 *Fireplace Flue Gas Temperature Measurement Device*—A 3.2 mm (0.125 in.) diameter sheathed, non-isolated junction Type K thermocouple capable of measuring flue gas temperature with an accuracy of 3°C (5.4°F), 2°C (3.6°F). Must meet calibration requirements specified in 8.4.

7.5 *Fireplace Temperature Measuring Device*—A temperature sensor capable of measuring firebox surface temperatures with an accuracy of 3°C (5.4°F), 2°C (3.6°F). Must meet calibration requirements specified in 8.4.

8. Calibration and Standardization

8.1 *Wood Moisture Meter*—Calibrate as in accordance with the manufacturer's instructions before each certification test.

8.2 *Platform Scale*—Perform a multipoint calibration (at least five points spanning the operational range) of the platform scale before its initial use. The scale manufacturer's calibration results are sufficient for this purpose. Before each certification test, audit the scale with the test fireplace in place by weighing at least one calibration weight (ASTM Class F) that corresponds to between 20 and 80 % of the expected test fuel charge weight. If the scale cannot reproduce the value of the calibration weight within 0.05 kg (0.1 lb) or 1 % of the expected test fuel charge weight, whichever is greater, recalibrate the scale before use with at least five calibration weights spanning the operational range of the scale.

8.3 *Test Fuel Scale*—Perform a multipoint calibration (at least five points spanning the operational range) of the test fuel scale before its initial use. The scale manufacturer's calibration results are sufficient for this purpose. Before each certification test, audit the scale with the wood heater in place by weighing at least one calibration weight (ASTM Class F) that corresponds to between 20 and 80 % of the expected test fuel charge weight. If the scale cannot reproduce the value of the calibration weight within 0.005 kg (0.01 lb) or 1 % of the expected test fuel charge weight, whichever is greater, recalibrate the scale before use with at least five calibration weights spanning the operational range of the scale.

8.4 *Temperature Sensors*—Temperature measuring equipment shall be calibrated before initial use and at least semi-annually thereafter. Calibrations shall be National Institute of Standards and Technology (NIST) traceable and demonstrate accuracy of $\pm 2^{\circ}\text{C}$ (3.6°F).

9. Procedure

~~9.1 Preconditioning of the Fireplace—The fireplace to be evaluated must be burned for at least 10 h prior to testing for emissions. This may be done inside or outside the test facility.~~

~~9.1.1 Set up the fireplace in accordance with instructions provided by the manufacturer. The total height of chimney when measured from the floor or top of the platform scale shall be 4.6 ± 0.3 m (15 ± 1 ft).~~

~~9.1.2 Install a flue-gas temperature measurement device at the center of the flue, 2.4 ± 0.1 m (8 ± 0.3 ft) above the floor.~~

~~9.1.3 Record the start time and flue gas temperature.—Prior to testing for emissions, the fireplace to be evaluated must be burned until the weight of the fireplace is stable to within ± 0.25 kg (± 0.5 lb) but for no less than 10 h. This may be done inside or outside the test facility.~~

9.1.1 Set up the fireplace in accordance with instructions provided by the manufacturer. The total height of chimney when measured from the base of the fireplace shall be 4.6 ± 0.3 m (15 ± 1 ft).

9.1.2 Install a flue-gas temperature measurement device at the center of the flue, 2.4 ± 0.1 m (8 ± 0.3 ft) above the base of the fireplace.

9.1.3 Record the start time, fireplace weight, and flue gas temperature.

9.1.4 Ignite a fire using newspaper and kindling and establish an actively burning fire. Add more fuel as needed to sustain the fire.

NOTE 1—Any type of untreated wood may be used for the preconditioning.

9.1.5 Record the time and weight for all fuel added.

9.1.6 Record the flue-gas temperature at least once during each 30 min of operation.

~~9.1.7 Record the ending time, total wood weight of wood burned, and total elapsed time of operation.~~

~~9.1.8 When the preconditioning fire is completed, allow the fireplace to cool to room temperature and remove all unburned wood, charcoal, ash, or other debris from the firebox.~~

~~9.1.9 Clean the chimney using a standard chimney brush appropriately sized for the chimney.~~

9.1.7 Periodically allow the fire to burn down completely. While the fireplace is still warm, shovel out all residual fuel, ash and other debris, lift the fireplace off the scale, re-zero the scale and return the fireplace to scale. Record the empty weight of the fireplace. Repeat this process of burning the fireplace and determining the empty weight until the weight becomes stable in accordance to the requirements of 9.1.

9.1.8 When the fireplace weight has stabilized or after 10 hours of preconditioning fires, which ever is longer, record the ending time, total wood weight of wood burned, and total elapsed time of operation.

9.1.9 Allow the fireplace to cool to room temperature and remove all unburned wood, charcoal, ash, or other debris from the firebox.

9.1.10 Clean the chimney using a standard chimney brush appropriately sized for the chimney.

9.2 Install the fireplace in the test facility.

9.2.1 Set up the fireplace in accordance with instructions provided by the manufacturer. Use the chimney type supplied or specified by the manufacturer. The total height of chimney when measured from the ~~top~~base of the ~~platform scale~~ fireplace shall be 4.6 ± 0.3 m (15 ± 1 ft). Do not install a chimney cap.

NOTE 2—The chimney that is used for testing should be documented in the test data and test report.

9.2.2 Center the flue outlet (chimney) under the dilution tunnel hood. Refer to Test Method E2515 for specific requirements including positioning the flue outlet to meet induced draft and smoke capture requirements.

9.2.3 Install a flue-gas temperature measurement device at the center of the flue, 2.4 ± 0.1 m (8 ± 0.3 ft) above the ~~floor~~ base of the fireplace.

9.3 Fuel:

9.3.1 Fuel Properties:

9.3.1.1 The fuel is untreated, standard, or better grade Douglas fir lumber.

9.3.1.2 Fuel Moisture—The fuel moisture shall be measured using a fuel moisture meter as specified in 7.1. Moisture shall not be added to previously dried fuel pieces. Fuel moisture shall be measured within four hours of using the fuel for a test.

(1) Kindling Loads—The average fuel moisture for each fuel strip used in each of the two specified kindling brands shall be between 6 and 12 % dry basis. Kiln-dried lumber is permitted for the kindling brands. Determine fuel moisture for each fuel strip. One moisture meter reading from each strip, measured parallel to the wood grain is sufficient. If an electrical resistance type fuel moisture meter is used, penetration of insulated electrodes shall be $\frac{1}{4}$ the thickness of the fuel strips. Average all the readings for all the fuel strips for ~~each~~both kindling brands combined to determine the average fuel moisture for ~~each kindling brand~~ all kindling.

(2) Main Fuel Cribs—The average fuel moisture for each fuel piece used to construct each of the three fuel cribs shall be between 19 and 25 % dry basis. Kiln-dried lumber is not permitted. Kiln-dried lumber is permitted for the spacers. Determine the fuel moisture for each fuel piece (excluding spacers) used for each of the three fuel cribs by averaging at least three fuel moisture meter readings, one from each of three sides, measured parallel to the wood grain. If an electrical resistance type fuel moisture meter is used, penetration of insulated electrodes shall be $\frac{1}{4}$ the thickness of the fuel piece or 19 mm ($\frac{3}{4}$ in.), whichever is greater.

Average all the fuel piece readings to determine the average fuel moisture for each fuel crib (in.), whichever is greater.

9.3.1.3 *Fuel Density*—The average fuel density, dry basis, shall be in the range of 0.434 to 0.546 g/cm³ (27 to 34 lb/ft³) for each of the kindling brands and three fuel cribs.) for the two kindling brands combined and for each of the three individual fuel cribs. Nails and spacer pieces are excluded from the density determinations. Determine the total volume of the fuel pieces that comprise both kindling brands combined and each individual fuel crib. Use the wet basis weight and the arithmetically averaged dry basis moisture content (refer to 9.3.1.2(1) and 9.3.1.2(2)) to determine the dry basis weight for the kindling and for the individual fuel crib pieces. Determine dry basis weight for each fuel crib by summing the dry basis weight of the individual fuel pieces that comprise each crib. Divide the dry basis weight by the volume to determine the density for the combined kindling brands and for each fuel crib.

9.3.1.4 *Nails*—Use uncoated, ungalvanized nails for assembling kindling brands and main fuel loads. In general, the number of nails used should be limited to the minimum number necessary to hold the kindling brands and fuel cribs together.

9.3.1.5 *Weight*—Record the total weight of each kindling brand or main fuel crib after it is assembled using the test fuel scale specified in 7.2. The weighed fuel brands and cribs must be used within 3 h of being weighed.

9.3.2 *Nominal Fuel Length*—The NFL for each fireplace being evaluated is determined based on dimensional parameters of the fireplace firebox or grate, or both.

9.3.2.1 If the fireplace includes a manufacturer supplied or specified grate (see Fig. 2), the NFL is:

- (1) The longest of the five standard fuel lengths that will fit in or on the grate without interference from any part of the grate structure, or;
- (2) If the grate does not include end log retainer bars that limit fuel length, the longest of the five standard fuel lengths that does not extend by more than 2 in. past the longest horizontal grate dimension when the fuel length is centered left-to-right on the grate, or;
- (3) If the 2-in. extension of the fuel past the longest grate dimension causes interference with the walls of the firebox, the longest of the standard fuel lengths that can be centered on the grate without interference from the firebox walls, or;
- (4) If the manufacturer’s written instructions that accompany the fireplace include a specific fuel piece length recommendation for the fireplace user, the recommended length shall be used.

NOTE 3—If the manufacturer’s recommended length is not one of the five standard fuel lengths, use the closest standard fuel length that does not exceed the manufacturer’s recommended length.

9.3.2.2 If the fireplace has no grate supplied or specified by the manufacturer, the NFL is the longest fuel length that will fit without interference from side walls of the firebox, while still allowing the front edge of the first kindling crib to be no closer to the front of the fireplace opening than 1/3 the depth of the fireplace. (See Fig. 3.)

(1) Standardized fuel retainers shall be used for any fireplace that does not have a grate.

9.3.2.3 Dimensional tolerance for the NFL is ±1.5 mm (1/16 in.).

9.3.3 *Newspaper:*

9.3.3.1 Loosely crumpled balls of full sheets of non-color ink newspaper are used to ignite the kindling loads. The number of balls is dependent on the NFL. The intent is to ensure rapid and even ignition of the kindling brands. The following guideline (Table 1) is given:

mm	NFL	in.	Newspaper # of Sheets
406		16	4
457		18	5
508		20	6
559		22	7
610		24	8

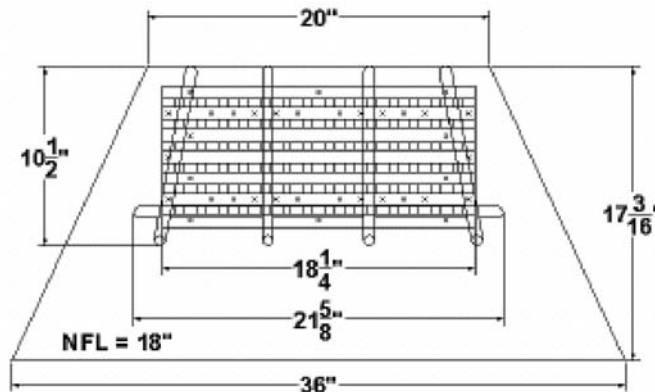

FIG. 2 NFL Example, Traditional, with Grate

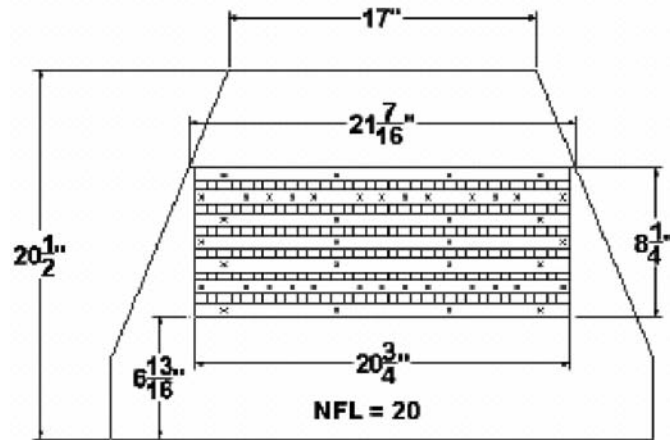

FIG. 3 NFL Example, Traditional, No Grate

9.3.4 *Kindling Loads*—There are two kindling brands that are used to establish an initial charcoal bed and to ignite the first fuel crib. The kindling brands are comprised of Douglas fir pieces that meet the specifications of 9.3.1.

9.3.4.1 *First Kindling Brand:*

9.3.4.1.1 The first kindling brand is comprised of two layers of 19 × 19 mm (3/4

(1) For fireplaces that include a grate or specify that a grate must be used, the first kindling brand is comprised of two layers of 19 × 19 mm (3/4 × 3/4 in.) strips of Douglas fir that meet the specifications of 9.3.1. The strips are spaced 12.7 mm (1/2 in.) apart and nailed together. The two layers are perpendicular to each other. (See Figs. 4 and 5 in.) The strips are spaced 12.7 mm (1/2 in.) apart and nailed together using 18 gauge or smaller nails no longer than 35 mm (1 3/8 in.). The two layers are perpendicular to each other. (See Fig. 4 and Fig. 6.)

(1)(a) The bottom layer is comprised of strips that are 210 mm long (8 1/4 in.) long. The number of strips is dependent on the NFL as determined in Table 3. (See Table 2.)

(1)(b) The top layer is comprised of seven strips. The top layer length (TLL) is determined by the NFL. (See Table 2.)

9.3.4.2 The second kindling brand is comprised of two layers of Douglas fir that meet the specifications of 9.3.1. The fuel pieces are nailed together. The two layers are perpendicular to each other. (See Fig. 6)

ASTM E2558-09
<https://standards.iteh.ai/catalog/standards/sist/e50eb5f3-5f5c-402c-bc2-86885cce6bd2/astm-e2558-09>

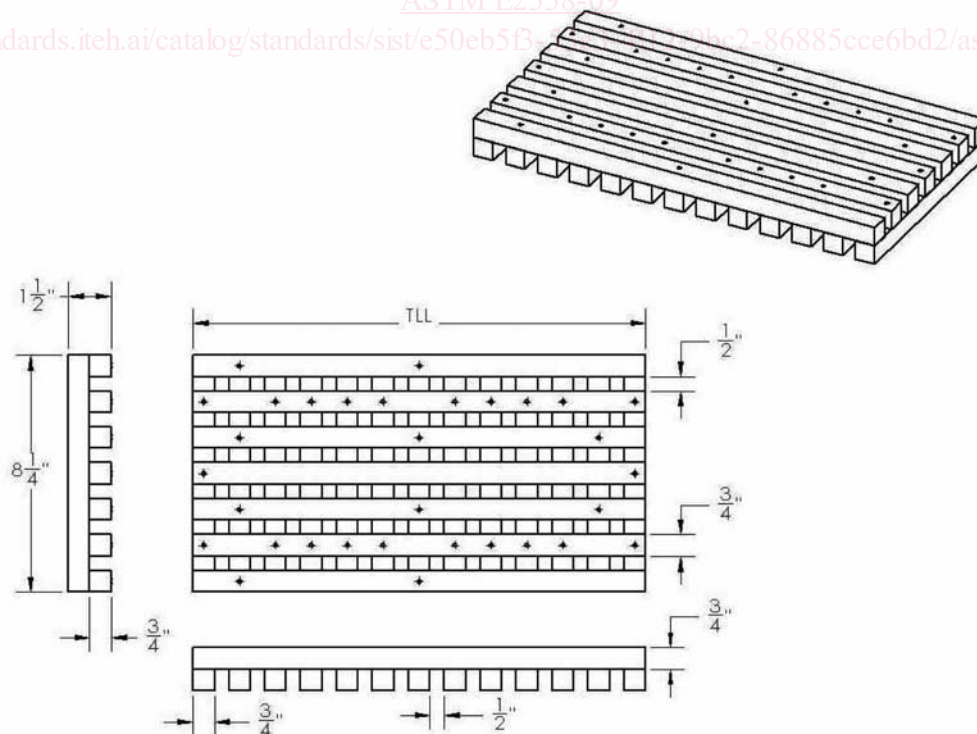

FIG. 4 Kindling Brand 1 (With Grate)

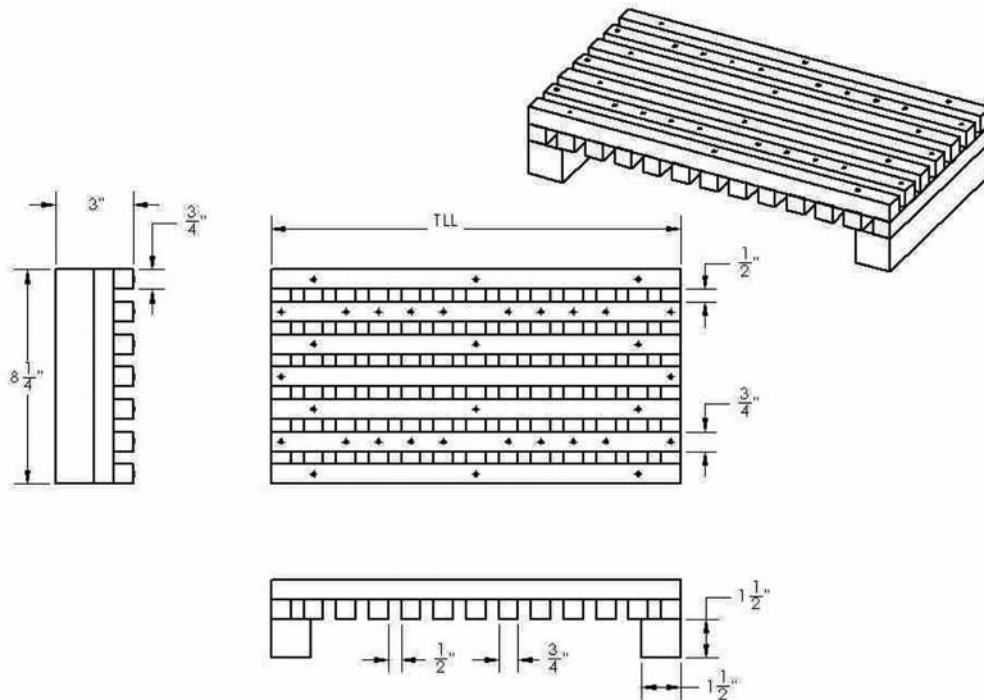

FIG. 5 Kindling Brand 1 (No Grate)

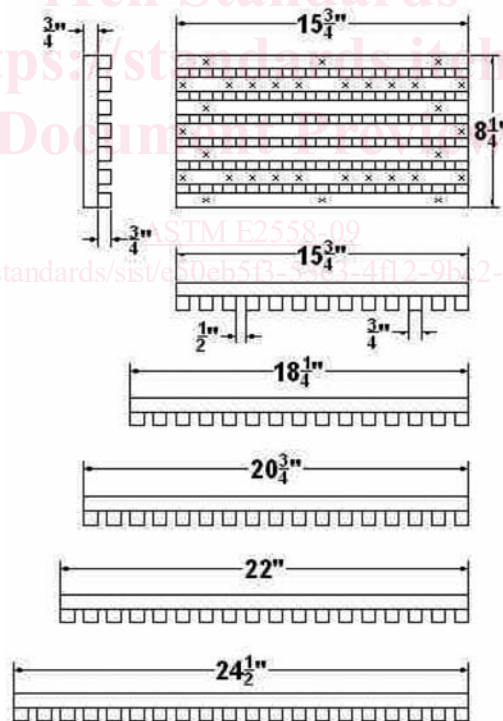

FIG. 6 Kindling Brand 1 (With Grate)

(2) For fireplaces that do not include a grate or do not specify a grate that must be used, the kindling brands and fuel loads are burned directly on the fireplace hearth and the first kindling brand is comprised of two layers of 19 mm × 19 mm (3/4 in. × 3/4 in.) strips constructed in accordance with 9.3.4.1(I) but with the addition of two spacer pieces that attached to the underside of the bottom layer of the brand. The spacers are comprised of 38 mm × 38 mm (1 1/2 in. × 1 1/2 in.) pieces. The spacers are 210 mm (8 1/4 in.) long and positioned at each end of the brand and parallel to the pieces that comprise the bottom layer of the brand. (See Fig. 5 and Fig. 7.)

9.3.4.2 *Second Kindling Brand*—The second kindling brand is comprised of two layers. The fuel pieces are nailed together

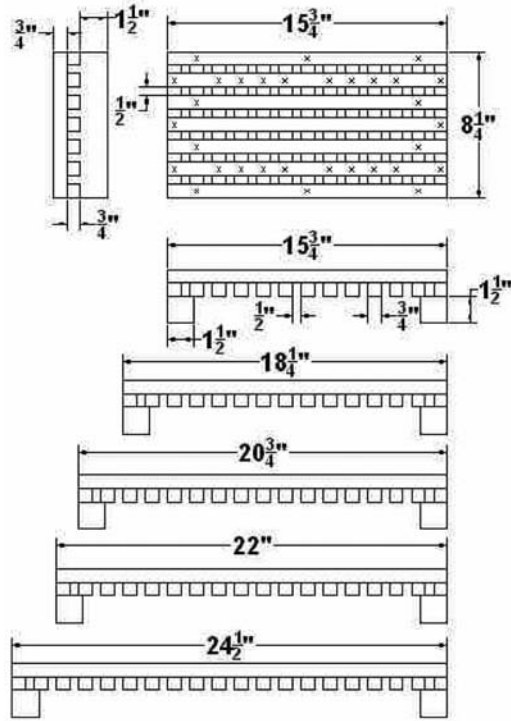

FIG. 7 Kindling Brand 1 (No Grate)

TABLE 2 Kindling Brand 1

NFL	Lower Layer		Top Layer Length	
	mm	in.	# of Strips	mm
406	16	13	400	15 ³ / ₄
457	18	15	464	18 ¹ / ₄
508	20	17	527	20 ³ / ₄
559	22	18	559	22
610	24	20	622	24 ¹ / ₂

TABLE 3 Kindling Brand 2

NFL	Lower Layer		Top Layer Length		
	mm	in.	# of 2 × 2	# of 1 × 2	mm
406	16	6	0	403	15 ⁷ / ₈
457	18	6	1	457	18
508	20	6	2	511	20 ¹ / ₈
559	22	8	0	549	21 ⁵ / ₈
610	24	8	1	591	23 ¹ / ₄

using 18 gauge or smaller nails no longer than 35 mm (1³/₈ in.). The two layers are perpendicular to each other. (See Fig. 8.)

(1) The bottom layer is comprised of 38 × 38 mm (1 1/2 × 1 1/2 in.) pieces or a combination of 38 × 38 mm (1 1/2 × 1 1/2 in.) and 19 × 38 mm (3/4 × 1 1/2 in.) pieces spaced 35 mm (1 3/8 in.) apart. Each piece is 210 mm (8 1/4 in.) long. The number and position of each strip is determined by the NFL. (See Fig. 6 Fig. 8 and Fig. 7 Fig. 9 and Table 3.)

(2) The top layer is comprised of four 19 × 19 mm (3/4 × 3/4 in.) strips. The outer strips are located at the ends of the lower layer pieces and the remaining two strips are spaced 38 mm (1 1/2 in.) from the first two. The TLL is determined by the NFL. (See Fig. 6 Fig. 8, Fig. 7 Fig. 9, and Table 3.)

9.3.4.3

9.3.5 Main Fuel Loads—There are three main fuel cribs that are added to the fire as described in 9.4. The cribs are comprised of dimensional lumber assembled in specific patterns with specific air spaces between the pieces. The dimensional lumber pieces are air-dried Douglas fir that meet the specifications of 9.3.1. The fuel spacer pieces are Douglas fir that meet the specifications of 9.3.1. All pieces are nailed together. See notes for each crib for suggestions on nailing.

9.3.4.4 All pieces are nailed together. Fuel spacer pieces are attached to the dimensional lumber pieces using 18 gauge or smaller nails no longer than 35 mm (1³/₈ in.).

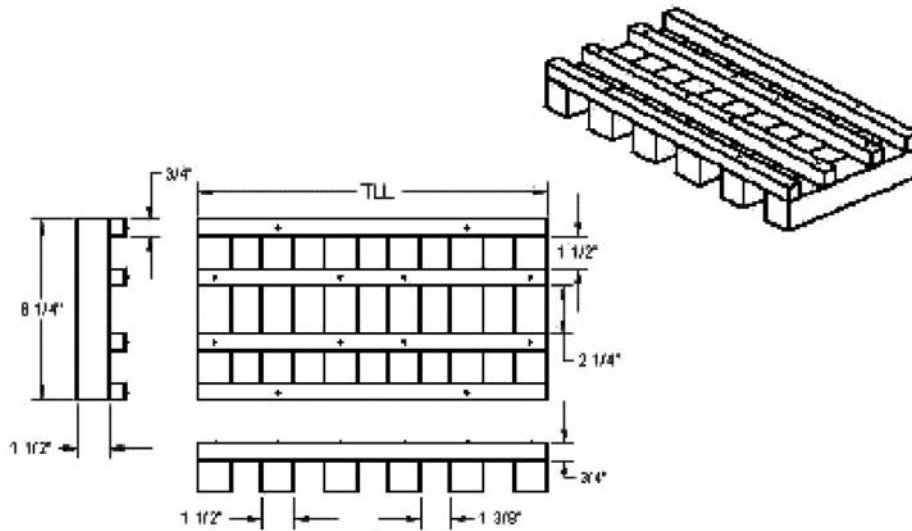

FIG.-6 8 Kindling Brand 2

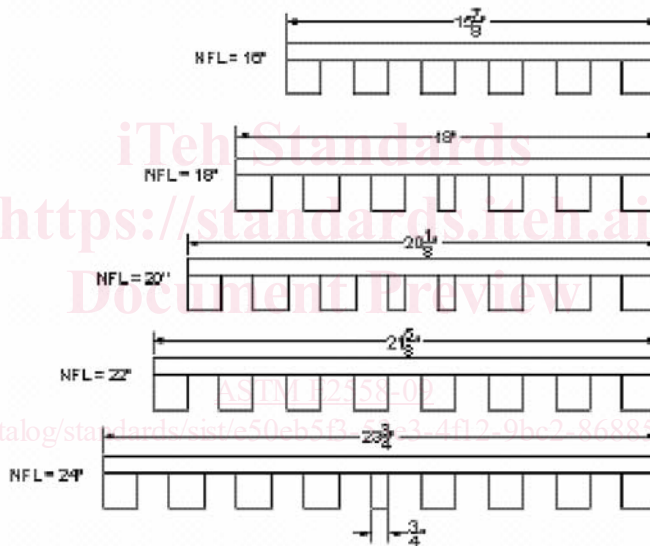

FIG.-7 9 Kindling Brand 2—Front View For Each NFL

9.3.5.1 *First Fuel Crib*—The first fuel crib is comprised of one fuel piece of 4 × 4 dimensional lumber and two fuel pieces of 2 × 4 dimensional lumber plus six spacers. The length of each fuel piece is the NFL as determined in 9.3.2. The 2 × 4 fuel pieces face the front of the fireplace and are offset from each other by 3 mm (1/8 in.). The crib is assembled using four 19 × 38 mm (3/4 × 1 1/2 in.) spacers and two 12.7 × 38 mm (1/2 × 1 1/2 in.) spacers. (See Fig. 8 Fig. 10 for the specific details of construction.)

9.3.4.5

9.3.5.2 *Second Fuel Crib*—The second fuel crib is comprised of two fuel pieces of 4 × 4 dimensional lumber and one fuel piece of 2 × 4 dimensional lumber plus two spacers. The length of each fuel piece is the NFL as determined in 9.3.2. The 2 × 4 fuel piece and one 4 × 4 fuel piece are nailed together with three 8-penny common nails to form a nominal 4 × 6 piece. The nails are centered on the width of the 89-mm (3 1/2-in.) face of the 2 × 4, with one nail at the center of the NFL and the other two spaced in 100 mm (4 in.) from each end. The crib is assembled using two 19 × 38 mm (3/4 × 1 1/2 in.) spacers so that the fuel pieces are rotated 45° from horizontal. The 4 × 4 faces the front of the fireplace. (See Fig. 9 Fig. 11 for the specific details of construction.)

9.3.4.6

9.3.5.3 *Third Fuel Crib*—The third fuel crib is comprised of two fuel pieces of 2 × 4 dimensional lumber plus spacers. The length of each fuel piece is the NFL as determined in 9.3.2. The crib is assembled using six 12.7 × 38 mm (1/2 × 1 1/2 in.) spacers. (See Fig. 10 Fig. 12 for the specific details of construction.)

9.4 Operation:

9.4.1 Prior to beginning a test, measure the temperature of the fireplace. Use a surface temperature probe held against the center of the back wall of the firebox until a constant temperature is obtained. The fireplace temperature must be within the allowable

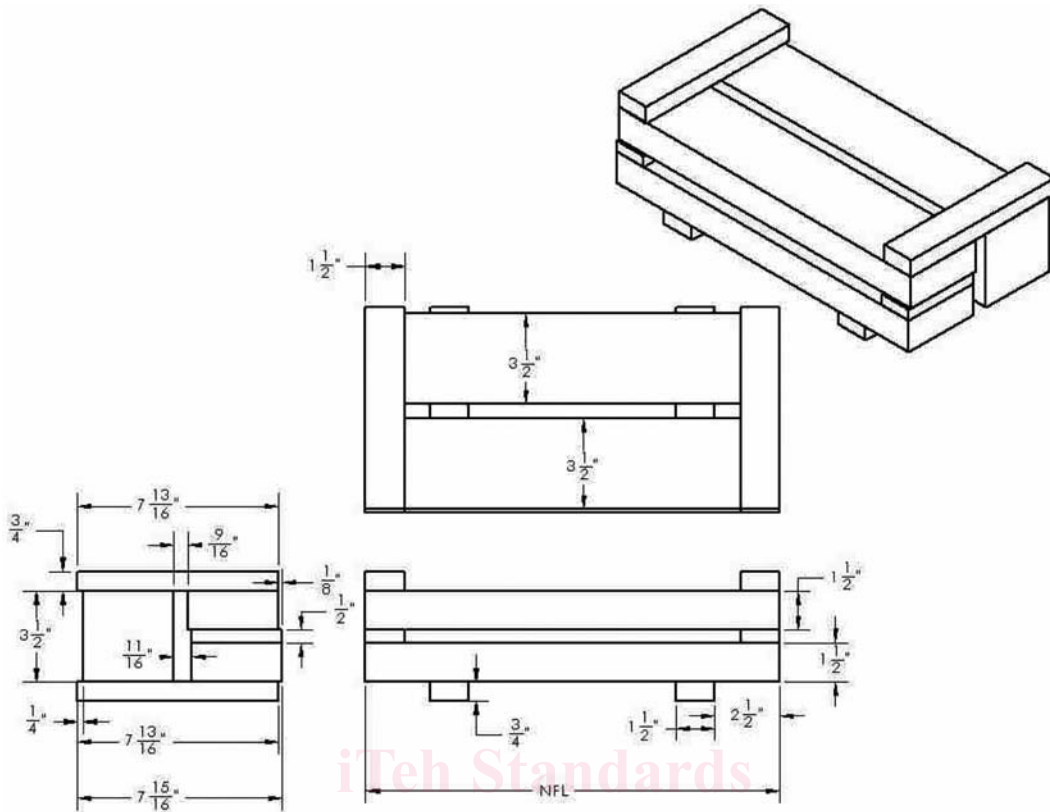

FIG. 10 First Fuel Crib

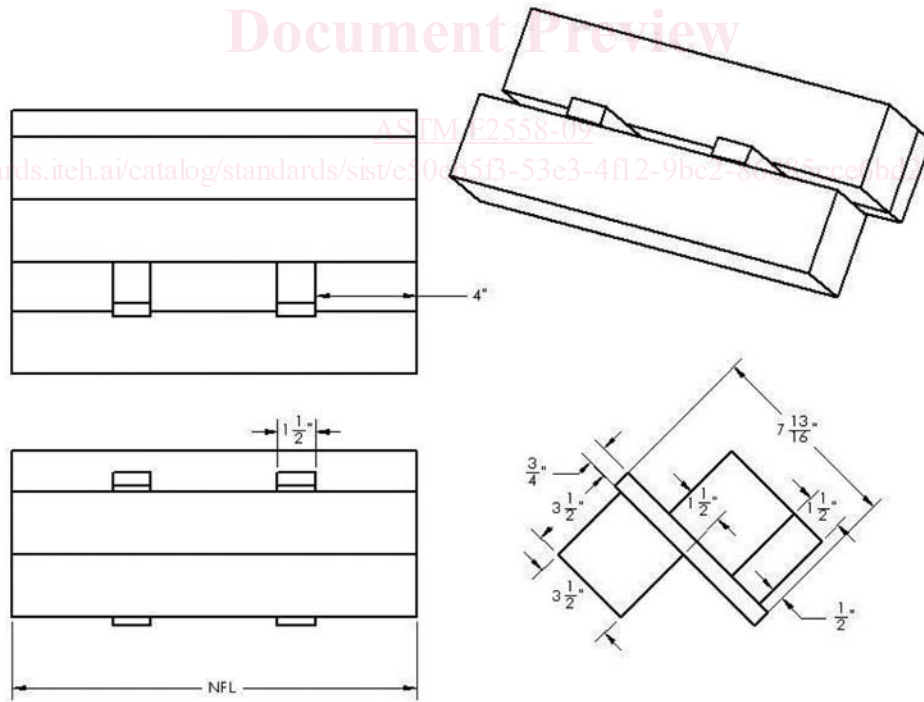

FIG. 11 Second Fuel Crib

test facility temperature range specified in Test Method E2515.

9.4.2 Within 10 min prior to starting the emissions test run, record the indicated scale weight of the empty fireplace/chimney assembly. If the test will be conducted using a standardized fuel retainer, include the weight of the fuel retainer in the empty fireplace weight. Note that after obtaining the empty starting weight of the fireplace/chimney assembly, tare the platform scale to obtain a zero empty starting weight if that function is available on your scale.