



Designation: E185 – 10

Standard Practice for Design of Surveillance Programs for Light-Water Moderated Nuclear Power Reactor Vessels¹

This standard is issued under the fixed designation E185; the number immediately following the designation indicates the year of original adoption or, in the case of revision, the year of last revision. A number in parentheses indicates the year of last reapproval. A superscript epsilon (ϵ) indicates an editorial change since the last revision or reapproval.

1. Scope

1.1 This practice covers procedures for designing a surveillance program for monitoring the radiation-induced changes in the mechanical properties of ferritic materials in light-water moderated nuclear power reactor vessels. This practice includes the minimum requirements for the design of a surveillance program, selection of vessel material to be included, and the initial schedule for evaluation of materials.

1.2 This practice was developed for all light-water moderated nuclear power reactor vessels for which the predicted maximum fast neutron fluence ($E > 1$ MeV) at the end of license (EOL) exceeds 1×10^{21} neutrons/m² (1×10^{17} n/cm²) at the inside surface of the reactor vessel.

1.3 This practice applies only to the planning and design of surveillance programs for reactor vessels designed and built after the effective date of this practice. Previous versions of Practice E185 apply to earlier reactor vessels.

1.4 This practice does not provide specific procedures for monitoring the radiation induced changes in properties beyond the design life, but the procedure described may provide guidance for developing such a surveillance program.

1.5 The values stated in SI units are to be regarded as the standard. The values given in parentheses are for information only.

NOTE 1—The increased complexity of the requirements for a light-water moderated nuclear power reactor vessel surveillance program has necessitated the separation of the requirements into three related standards. Practice E185 describes the minimum requirements for a surveillance program. Practice E2215 describes the procedures for testing and evaluation of surveillance capsules removed from a surveillance program as defined in the current or previous editions of Practice E185. Guide E636 provides guidance for conducting additional mechanical tests. A summary of the many major revisions to Practice E185 since its original issuance is contained in Appendix X1.

¹ This practice is under the jurisdiction of ASTM Committee E10 on Nuclear Technology and Applications and is the direct responsibility of Subcommittee E10.02 on Behavior and Use of Nuclear Structural Materials.

Current edition approved March 1, 2010. Published April 2010. Originally approved in 1961 as E185 – 61 T. Last previous edition approved in 2002 as E185 – 02. DOI: 10.1520/E0185-10.

2. Referenced Documents

2.1 ASTM Standards:²

- A370 Test Methods and Definitions for Mechanical Testing of Steel Products
- A751 Test Methods, Practices, and Terminology for Chemical Analysis of Steel Products
- E8/E8M Test Methods for Tension Testing of Metallic Materials
- E21 Test Methods for Elevated Temperature Tension Tests of Metallic Materials
- E23 Test Methods for Notched Bar Impact Testing of Metallic Materials
- E170 Terminology Relating to Radiation Measurements and Dosimetry
- E208 Test Method for Conducting Drop-Weight Test to Determine Nil-Ductility Transition Temperature of Ferritic Steels
- E482 Guide for Application of Neutron Transport Methods for Reactor Vessel Surveillance, E706 (IID)
- E636 Guide for Conducting Supplemental Surveillance Tests for Nuclear Power Reactor Vessels, E 706 (IH)
- E844 Guide for Sensor Set Design and Irradiation for Reactor Surveillance, E 706 (IIC)
- E900 Guide for Predicting Radiation-Induced Transition Temperature Shift in Reactor Vessel Materials, E706 (IIF)
- E1214 Guide for Use of Melt Wire Temperature Monitors for Reactor Vessel Surveillance, E 706 (IIIE)
- E1253 Guide for Reconstitution of Irradiated Charpy-Sized Specimens
- E1820 Test Method for Measurement of Fracture Toughness
- E1921 Test Method for Determination of Reference Temperature, T_0 , for Ferritic Steels in the Transition Range
- E2215 Practice for Evaluation of Surveillance Capsules from Light-Water Moderated Nuclear Power Reactor Vessels

² For referenced ASTM standards, visit the ASTM website, www.astm.org, or contact ASTM Customer Service at service@astm.org. For *Annual Book of ASTM Standards* volume information, refer to the standard's Document Summary page on the ASTM website.

2.2 ASME Standards:³

American Society of Mechanical Engineers, Boiler and Pressure Vessel Code, Sections III and XI

ASME Boiler and Pressure Vessel Code Case N-629, Use of Fracture Toughness Test Data to Establish Reference Temperature for Pressure Retaining Materials, Section XI, Division 1

ASME Boiler and Pressure Vessel Code Case N-631, Use of Fracture Toughness Test Data to Establish Reference Temperature for Pressure Retaining Materials Other Than Bolting for Class 1 Vessels, Section III, Division 1

3. Terminology

3.1 Definitions:

3.1.1 *base metal*—as-fabricated plate material or forging material other than a weld or its corresponding heat-affected-zone (HAZ).

3.1.2 *beltline*—the irradiated region of the reactor vessel (shell material including weld seams and plates or forgings) that directly surrounds the effective height of the active core. Note that materials in regions adjacent to the beltline may sustain sufficient neutron damage to warrant consideration in the selection of surveillance materials.

3.1.3 *Charpy transition temperature curve*—a graphic or curve-fitted presentation, or both, of absorbed energy, lateral expansion, and fracture appearance as functions of test temperature, extending over a range including the lower shelf (5 % or less shear fracture appearance), transition region, and the upper shelf (95 % or greater shear fracture appearance).

3.1.4 *Charpy transition temperature shift*—the difference in the 40.7 J (30 ft-lbf) index temperatures for the best fit (average) Charpy absorbed energy curve measured before and after irradiation.

3.1.5 *Charpy upper-shelf energy level*—the average energy value for all Charpy specimen tests (preferably three or more) whose test temperature is at or above the Charpy upper-shelf onset; specimens tested at temperatures greater than 83°C (150°F) above the Charpy upper-shelf onset shall not be included, unless no data are available between the onset temperature and onset +83°C (+150°F).

3.1.6 *Charpy upper-shelf onset*—the test temperature above which the fracture appearance of all Charpy specimens tested is at or above 95 % shear.

3.1.7 *end-of-license (EOL)*—the design lifetime in terms of years corresponding to the operating license period.

3.1.8 *heat-affected-zone (HAZ)*—plate material or forging material extending outward from, but not including, the weld fusion line in which the microstructure of the base metal has been altered by the heat of the welding process.

3.1.9 *index temperature*—that temperature corresponding to a predetermined level of absorbed energy, lateral expansion, or fracture appearance obtained from the best-fit (average) Charpy transition curve.

3.1.10 *lead factor*—the ratio of the peak neutron fluence ($E > 1$ MeV) of the specimens in a surveillance capsule to the peak neutron fluence ($E > 1$ MeV) at the reactor pressure vessel inside surface.

3.1.10.1 *Discussion*—Changes in the reactor operating parameters and fuel management may cause the lead factor to change.

3.1.11 *limiting materials*—the weld and base material with the highest predicted transition temperature at EOL determined by adding the appropriate transition temperature shift to the unirradiated RT_{NDT} . The reference temperature shift can be determined from the relationship found in Guide E900. The basis for selecting the limiting material shall be documented.

3.1.12 *reference material*—any steel that has been characterized as to the sensitivity of its tensile, impact and fracture toughness properties to neutron radiation embrittlement.

3.1.13 *reference temperature (RT_{NDT})*—see subarticle NB-2300 of the ASME Boiler and Pressure Vessel Code, Section III, “Nuclear Power Plant Components” for the definition of RT_{NDT} for unirradiated material based on Charpy (Test Method E23) and drop weight tests (Test Method E208). ASME Code Cases N-629 and N-631 provide an alternative definition for the reference temperature (RT_{To}) based on fracture toughness properties (Test Method E1921)

3.1.14 *standby capsule*—a surveillance capsule meeting the recommendations of this practice that is in the reactor vessel irradiation location, but whose withdrawal is not required by this practice.

3.2 Neutron Exposure Terminology:

3.2.1 Definitions of terms related to neutron dosimetry and exposure are provided in Terminology E170.

4. Significance and Use

4.1 Predictions of neutron radiation effects on pressure vessel steels are considered in the design of light-water moderated nuclear power reactors. Changes in system operating parameters often are made throughout the service life of the reactor vessel to account for radiation effects. Due to the variability in the behavior of reactor vessel steels, a surveillance program is warranted to monitor changes in the properties of actual vessel materials caused by long-term exposure to the neutron radiation and temperature environment of the reactor vessel. This practice describes the criteria that should be considered in planning and implementing surveillance test programs and points out precautions that should be taken to ensure that: (1) capsule exposures can be related to beltline exposures, (2) materials selected for the surveillance program are samples of those materials most likely to limit the operation of the reactor vessel, and (3) the test specimen types are appropriate for the evaluation of radiation effects on the reactor vessel.

4.2 The methodology to be used in estimation of neutron exposure obtained for reactor vessel surveillance programs is defined in Guide E482.

4.3 The design of a surveillance program for a given reactor vessel must consider the existing body of data on similar

³ Available from the American Society of Mechanical Engineers, Third Park Avenue, New York, NY 10016.

materials in addition to the specific materials used for that reactor vessel. The amount of such data and the similarity of exposure conditions and material characteristics will determine their applicability for predicting radiation effects.

5. Surveillance Program Design

5.1 This section describes the minimum requirements for the design of a surveillance program for monitoring the radiation-induced changes in the mechanical properties of ferritic materials in the reactor vessel.

5.2 Test Materials:

5.2.1 *Materials Selection*—The surveillance test materials shall include, at minimum, the limiting base metal heat and the limiting weld. If a limiting material is outside the beltline, the limiting beltline base and weld materials shall also be included.

NOTE 2—The predicted limiting material may change during operation. Therefore, it is prudent to include additional potentially limiting beltline materials in the surveillance program as capsule space permits.

5.2.2 *Material Sampling*—A minimum test program shall consist of the material selected in 5.2.1, taken from the following: (1) base metal from the actual plate(s) or forging(s) used in the reactor vessel, and (2) weld metal(s) made with the same heat of weld wire and lot of flux and by the same welding procedure as that used for the reactor vessel welds. The base metal used to fabricate the weldment(s) shall be one of the base metals included in the surveillance program. Surveillance test materials shall be full thickness samples.

NOTE 3—Experience has shown that it is no longer necessary to include the heat-affected zone material in the surveillance program. However, it is recommended that the heat-affected-zone material be included with the archives (see 5.2.5).

5.2.3 *Fabrication History*—The fabrication history (austenitizing, quench and tempering, and post-weld heat treatment) of the test materials shall be fully representative of the fabrication history of the reactor vessel materials selected in 5.2.1 and shall be recorded.

5.2.4 *Chemical Analysis Requirements*—The chemical analysis required by the appropriate product specifications for the surveillance test materials (base metal and as-deposited weld metal) shall be recorded and shall include phosphorus (P), sulfur (S), copper (Cu), vanadium (V), silicon (Si), manganese (Mn), and nickel (Ni), as well as all other alloying and residual elements commonly analyzed for in low-alloy steel products. The product analysis shall be as described in Test Method A751 and verified by analyzing samples selected from the base metal and the as-deposited weld metal.

5.2.5 *Archive Materials*—Test stock to fill up to six additional capsules beyond the minimum number required for testing with test specimens of the base metal and weld materials used in the program shall be retained with full documentation and identification. This stock should be in the form of full-thickness sections of the original materials (plates, forgings, and welds) except specimens included in standby capsules. It is recommended that the heat-affected-zone material associated with the archive weld material be retained to provide supplemental data.

5.3 Test Specimens

5.3.1 *Type of Specimens*—Charpy V-notch specimens corresponding to the Type A specimen described in Test Methods A370 and E23 shall be used. Tension specimens of the type, size, and shape described in Test Methods A370 and E8/E8M are recommended. The gage section of irradiated and unirradiated tension specimens shall be of the same size and shape. Fracture toughness test specimens shall be consistent with the guidelines provided in Test Methods E1820 and E1921.

5.3.2 *Specimen Orientation and Location*—Tension, Charpy and fracture toughness specimens representing the base metal shall be removed from about the quarter-thickness ($1/4$ -T or $3/4$ -T) locations. Material from the mid-thickness of the base metal shall not be used for test specimens. Specimens representing weld metal may be removed from any location throughout the thickness with the exception of locations within 12.7 mm ($1/2$ in.) of the root or surfaces of the welds. Special attention must be given to defining the root of the weld in order to avoid taking weld metal that is different in composition from the surveillance weld metal. The tension and Charpy specimens from base metal shall be oriented so that the major axis of the specimen is parallel to the surface and normal to the principal rolling direction for plates, or normal to the major working direction for forgings shown in Test Method E23, Annex A5 (T-L orientation). The axis of the notch of the Charpy specimen for base metal and weld metal shall be oriented perpendicular to the surface of the material. The recommended orientation of the weld metal specimens is shown in Fig. 1. Weld metal tension specimens may be oriented in the same direction as the Charpy specimens provided that the gage length consists entirely of weld metal. The fracture toughness specimens shall have the same orientation as the Charpy specimens in both the base metal and weld metal.

5.4 Number of Specimens

5.4.1 *Unirradiated Baseline Specimens*—A minimum of 15 Charpy specimens shall be tested to establish full Charpy transition temperature curves for each material per Test Method E23. Instrumented tests are recommended and should be performed in accordance with Guide E636. It is recommended that upper-shelf Charpy tests be conducted at multiple temperatures using at least three specimens tested below the irradiation temperature and above the upper-shelf onset. At least six tension test specimens shall be tested to establish the unirradiated tensile properties for both the base metal and the weld metal. A minimum of two specimens at room temperature (per Test Method E8/E8M) and two specimens at reactor vessel beltline operating temperature (per Test Method E21) should be tested. The remainder of the tensile specimens may be tested at intermediate temperatures as needed to define the effects of temperature on the tensile properties. It is recommended that a minimum of 8 fracture toughness specimens be tested to establish the reference temperature, T_0 , per Test Method E1921 for the limiting material. Optionally, fracture toughness tests can be performed to establish the upper-shelf toughness following Test Method E1820.

5.4.2 *Irradiated Specimens*—The minimum number of test specimens for each irradiation exposure set (capsule) shall be as follows:

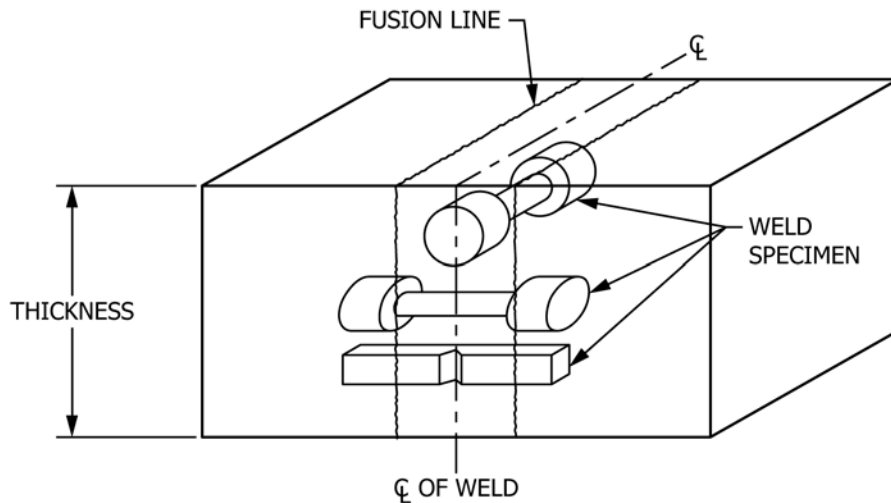

FIG. 1 Location of Test Specimens Within Weld Material

Material	Charpy	Tension	Fracture Toughness
Each Base Metal	15	3	8 ^A
Each Weld Metal	15	3	8 ^A

^A Only fracture toughness specimens from the limiting material are required. It is suggested that a greater quantity of specimens be included in the irradiation capsules whenever possible.

5.5 Irradiation Requirements:

5.5.1 *Encapsulation of Specimens*—Specimens should be maintained in an inert environment within a corrosion-resistant capsule to prevent deterioration of the surface of the specimens during radiation exposure. Care should be exercised in the design of the capsule to ensure that the temperature history of the specimens matches, as closely as possible, the temperature experienced by the reactor vessel. Surveillance capsules shall be designed to prevent mechanical damage to the specimens and monitors during irradiation. The design of the capsule and capsule attachments shall also permit insertion of replacement capsules into the reactor vessel if required at a later time in the lifetime of the vessel. The design of the capsule holder and the means of attachment shall (1) preclude structural material degradation at the attachment, (2) avoid interference with in-service inspection required by ASME Code Section XI, and (3) ensure the integrity of the capsule holder during the service life of the reactor vessel.

5.5.2 *Location of Capsules:*

5.5.2.1 *Vessel Capsules (Required)*—Surveillance capsules shall be located within the reactor vessel so that the specimen irradiation history duplicates as closely as possible, within the physical constraints of the system, the neutron spectrum, temperature history, and maximum neutron fluence experienced by the reactor vessel. The surveillance lead factor should be greater than 1.5 and less than five. A lead factor near 1.5 will provide data that will closely duplicate the fluence of the vessel material and will enable monitoring through most of the operating lifetime. Capsules with higher lead factors will provide data earlier in plant life but will limit monitoring capability for the later portion of the operating lifetime because it may be necessary to remove all the remaining capsules before EOL due to the high fluence accumulation rate. Data

from capsules with lead factors higher than five may be affected by the difference in fluence rate. This range of lead factors has been selected to minimize the calculational uncertainties in extrapolating the surveillance measurements from the specimens to the reactor vessel wall and to optimize the ability of the program to monitor material property changes throughout the life of the reactor vessel. During the service life of the reactor vessel the lead factors for individual capsules may change as a result of changes in fuel management.

5.5.2.2 *Accelerated Irradiation Capsules (Optional)*—The design of some reactor vessel or core internals may not allow the positioning of all surveillance capsules in low lead factor locations. Additional test specimens may be positioned at locations closer to the core than those described in 5.5.2.1 for accelerated irradiation. Plants with lead factors greater than five should provide a method of verifying the validity of the accelerated irradiation data. This verification may be accomplished by the inclusion of a reference material (see 5.6).

5.5.3 *Neutron Dosimeters:*

5.5.3.1 *Selection of Neutron Dosimeters*—Neutron dosimeters for the surveillance capsules shall be selected according to Guides E482 and E844. The group of dosimeters selected shall be capable of providing information about fast neutron fluence, fluence rate, and spectrum; and thermal neutron fluence and fluence rate information; and displacements per atom (dpa) and dpa rate in iron.

5.5.3.2 *Location of Neutron Dosimeters*—Dosimeters shall be located within each vessel wall capsule (see 5.5.2.1) and each accelerated capsule (see 5.5.2.2) if used.

5.5.3.3 Separate dosimeter capsules should also be used to monitor radiation conditions independent of the specimen capsules if it is expected that the withdrawal schedule will otherwise result in a delay in obtaining timely fluence data.

5.6 *Reference Materials:*

5.6.1 *Use of Reference Materials*—The use of a reference material is optional. If used, a reference material can provide an independent check for deviations from the expected surveillance capsule irradiation conditions (for example, temperature, neutron fluence rate, and neutron energy spectrum).