

FINAL  
DRAFT

INTERNATIONAL  
STANDARD

ISO/FDIS  
22497

ISO/TC 162

Secretariat: JISC

Voting begins on:  
**2021-03-31**

Voting terminates on:  
**2021-05-26**

---

---

## Doors, windows and curtain walling — Curtain walling — Vocabulary

*Portes, fenêtres et façades-rideaux — Façades-rideaux — Vocabulaire*

**iTeh STANDARD PREVIEW**  
**(standards.iteh.ai)**

[ISO/FDIS 22497](https://standards.iteh.ai/catalog/standards/sist/7b0411f9-7388-4beb-90d7-1791fcdd5cd7/iso-fdis-22497)

<https://standards.iteh.ai/catalog/standards/sist/7b0411f9-7388-4beb-90d7-1791fcdd5cd7/iso-fdis-22497>

RECIPIENTS OF THIS DRAFT ARE INVITED TO SUBMIT, WITH THEIR COMMENTS, NOTIFICATION OF ANY RELEVANT PATENT RIGHTS OF WHICH THEY ARE AWARE AND TO PROVIDE SUPPORTING DOCUMENTATION.

IN ADDITION TO THEIR EVALUATION AS BEING ACCEPTABLE FOR INDUSTRIAL, TECHNOLOGICAL, COMMERCIAL AND USER PURPOSES, DRAFT INTERNATIONAL STANDARDS MAY ON OCCASION HAVE TO BE CONSIDERED IN THE LIGHT OF THEIR POTENTIAL TO BECOME STANDARDS TO WHICH REFERENCE MAY BE MADE IN NATIONAL REGULATIONS.



Reference number  
ISO/FDIS 22497:2021(E)

© ISO 2021

## iTeh STANDARD PREVIEW (standards.iteh.ai)

[ISO/FDIS 22497](https://standards.iteh.ai/catalog/standards/sist/7b0411f9-7388-4beb-90d7-1791fcdd5cd7/iso-fdis-22497)

<https://standards.iteh.ai/catalog/standards/sist/7b0411f9-7388-4beb-90d7-1791fcdd5cd7/iso-fdis-22497>



### **COPYRIGHT PROTECTED DOCUMENT**

© ISO 2021

All rights reserved. Unless otherwise specified, or required in the context of its implementation, no part of this publication may be reproduced or utilized otherwise in any form or by any means, electronic or mechanical, including photocopying, or posting on the internet or an intranet, without prior written permission. Permission can be requested from either ISO at the address below or ISO's member body in the country of the requester.

ISO copyright office  
CP 401 • Ch. de Blandonnet 8  
CH-1214 Vernier, Geneva  
Phone: +41 22 749 01 11  
Email: [copyright@iso.org](mailto:copyright@iso.org)  
Website: [www.iso.org](http://www.iso.org)

Published in Switzerland

# Contents

	Page
Foreword .....	iv
<b>1 Scope</b> .....	<b>1</b>
<b>2 Normative references</b> .....	<b>1</b>
<b>3 Terms and definition</b> .....	<b>1</b>
<b>Annex A (informative) Illustration of the various defined terms</b> .....	<b>5</b>
<b>Bibliography</b> .....	<b>16</b>
<b>Index</b> .....	<b>17</b>

## iTeh STANDARD PREVIEW (standards.iteh.ai)

[ISO/FDIS 22497](https://standards.iteh.ai/catalog/standards/sist/7b0411f9-7388-4beb-90d7-1791fcdd5cd7/iso-fdis-22497)

<https://standards.iteh.ai/catalog/standards/sist/7b0411f9-7388-4beb-90d7-1791fcdd5cd7/iso-fdis-22497>

## Foreword

ISO (the International Organization for Standardization) is a worldwide federation of national standards bodies (ISO member bodies). The work of preparing International Standards is normally carried out through ISO technical committees. Each member body interested in a subject for which a technical committee has been established has the right to be represented on that committee. International organizations, governmental and non-governmental, in liaison with ISO, also take part in the work. ISO collaborates closely with the International Electrotechnical Commission (IEC) on all matters of electrotechnical standardization.

The procedures used to develop this document and those intended for its further maintenance are described in the ISO/IEC Directives, Part 1. In particular the different approval criteria needed for the different types of ISO documents should be noted. This document was drafted in accordance with the editorial rules of the ISO/IEC Directives, Part 2 (see [www.iso.org/directives](http://www.iso.org/directives)).

Attention is drawn to the possibility that some of the elements of this document may be the subject of patent rights. ISO shall not be held responsible for identifying any or all such patent rights. Details of any patent rights identified during the development of the document will be in the Introduction and/or on the ISO list of patent declarations received (see [www.iso.org/patents](http://www.iso.org/patents)).

Any trade name used in this document is information given for the convenience of users and does not constitute an endorsement.

For an explanation on the voluntary nature of standards, the meaning of ISO specific terms and expressions related to conformity assessment, as well as information about ISO's adherence to the World Trade Organization (WTO) principles in the Technical Barriers to Trade (TBT) see the following URL: [www.iso.org/iso/foreword.html](http://www.iso.org/iso/foreword.html). (standards.iteh.ai)

This document was prepared by Technical Committee ISO/TC 162, *Doors, windows and curtain walling*.  
ISO/FDIS 22497

Any feedback or questions on this document should be directed to the user's national standards body. A complete listing of these bodies can be found at [www.iso.org/members.html](http://www.iso.org/members.html).

# Doors, windows and curtain walling — Curtain walling — Vocabulary

## 1 Scope

This document provides definitions for terms used in documents, drawings, specifications, etc., when referring to the detailed elements of curtain walling.

It provides a comprehensive, though not total, list of regular terms.

It does not set out to repeat those physical definitions properly included within individual curtain walling standards related to performance requirements and associated test methods.

## 2 Normative references

There are no normative references in this document.

## 3 Terms and definition

ISO and IEC maintain terminological databases for use in standardization at the following addresses:

— ISO Online browsing platform: available at <https://www.iso.org/obp>

— IEC Electropedia: available at <http://www.electropedia.org/>

### 3.1

#### **bonded glazing**

type of curtain walling where the glass is primarily retained by a perimeter sealant and maybe with a supplementary mechanical restraint (see [Figure A.8](#))

Note 1 to entry: Formerly known as structural sealant glazing (SSGS).

### 3.2

#### **cassette construction**

type of curtain walling construction comprising glazed or infilled sub-frames inserted in to a framework of usually vertical and/or horizontal profiles

### 3.3

#### **coping**

component which protects the junction between the curtain walling and the roof edge from weather (see [Figure A.9](#))

### 3.4

#### **cover cap**

#### **face cover**

profiled external cover applied, usually snap fitted, over the face of the pressure plate to provide an architectural finish (see [Figure A.1](#) and [Figure A.3](#))

### 3.5

#### **cradle guide**

#### **gondola guide**

specially profiled continuous recess or projection designed into or separately attached to the mullion to provide a location guide for an access cradle (see [Figure A.1](#))

### 3.6

#### **curtain walling**

part of the building envelope made of a framework usually consisting of horizontal and vertical profiles, connected together and anchored to the supporting structure of the building, and containing fixed and/or openable infills, which provides all the required functions of an internal or external wall or part thereof, but does not contribute to the load bearing or the stability of the structure of the building

Note 1 to entry: Curtain walling is designed as a self-supporting construction which transmits dead-loads, imposed loads, environmental loads (wind, snow, etc.) and seismic loads to the main building structure.

Note 2 to entry: In some English speaking countries, the term “curtain wall” is also used to describe curtain walling.

Note 3 to entry: The term “curtain wall” in English may be used for other types of external wall.

Note 4 to entry: Fixed and/or openable infills can be described as fixed and/or openable parts in some countries.

### 3.7

#### **double skin curtain walling**

type of curtain walling comprising inner and outer skins and an air cavity, designed and supported as an integrated system fulfilling the functions of the curtain walling (see [Figure A.7](#))

### 3.8

#### **drainage hole weep hole**

opening through which water drains to the building exterior (see [Figure A.3](#) and [Figure A.11](#))

### 3.9

#### **external glazing gasket**

preformed resilient profiled length of sealing material installed between the external face of a glass pane, insulating glass unit or infill panel and the surrounding frame, glazing bead or pressure plate (see [Figure A.3](#) and [Figure A.4](#))

iteh STANDARD PREVIEW

(standards.iteh.ai)

<https://standards.iteh.ai/catalog/standards/sist/7b0411f9-7388-4beb-90d7-1791fcdd5cd7/iso-fdis-22497>

### 3.10

#### **fixing bracket**

assembly of components designed to transmit all actions on the curtain walling back to the building structure while allowing any required movement (see [Figure A.1](#))

### 3.11

#### **glazing bead**

length of profiled material used around the periphery of a pane of glass, insulating glass unit or infill panel to secure it in its frame

Note 1 to entry: Term “glazing stop” is also used in some countries.

### 3.12

#### **glazing seal**

amorphous sealing material installed between face of a glass pane, insulating glass unit or infill panel and the surrounding frame, glazing bead or pressure plate

### 3.13

#### **head**

horizontal framing member positioned at the top of the curtain walling or at the top of an area of glass, windows, panels or doors (see [Figure A.1](#))

### 3.14

#### **infill panel**

translucent or opaque filler or facing material, either of one piece or an assembly, installed within a surrounding frame ([Figure A.1](#), [Figure A.4](#) and [Figure A.5](#))

**3.15****infill support**

device designed to transfer the dead load of the infill to the framing members (see [Figure A.11](#))

Note 1 to entry: When the infill material is glass, the term used is "glazing support".

**3.16****insulating glass unit****IGU**

composite unit of two or more panes of glazing hermetically sealed to provide an improved performance of thermal and acoustic insulation (see [Figure A.4](#))

**3.17****internal glazing gasket**

preformed resilient shaped length of sealing material installed between the internal face of a glass pane, insulating glass unit or infill panel and its surrounding frame or glazing bead (see [Figure A.3](#) and [Figure A.4](#))

**3.18****jamb**

vertical framing member positioned at the vertical edge of the curtain walling (see [Figure A.1](#))

**3.19****movement joint**

joint to accommodate thermal or other movements arising from the curtain walling or the supporting structure

**iTeh STANDARD PREVIEW**

**3.20****mullion**

vertical framing member of a curtain walling (see [Figure A.1](#), [Figure A.2](#) and [Figure A.3](#))

<https://standards.iteh.ai/catalog/standards/sist/7b0411f9-7388-4beb-90d7-1791fcdd5cd7/iso-fdis-22497>

**3.21****perimeter seal**

joint between the curtain walling and adjacent construction designed to give continuity at both the air and water barriers of the wall (see [Figure A.1](#))

**3.22****pressure equalization**

method of sealing and compartmenting the wall that enables the rapid minimization of differential air pressure between cold facade cavities or glazing rebates and the external air (see [Figure A.4](#))

**3.23****pressure plate**

length of profiled material attached to mullions and/or transoms around the perimeter of a pane of glass, insulating glass unit or infill panel to provide restraint and usually compress the glazing gasket (see [Figure A.3](#), [Figure A.4](#) and [Figure A.11](#))

**3.24****setting block**

small block of suitable material, placed under the lower edge of a pane of glass, insulating glass unit or infill panel when setting it in a frame (see [Figure A.4](#))

**3.25****sill**

horizontal framing member positioned at the base of an area of glass, windows, panels or doors (see [Figure A.1](#))

**3.26****spandrel area**

area of a curtain walling between two horizontal zones, normally between glazing and concealing the edge of the floor slab (see [Figure A.9](#))

**3.27**

**spigot  
mullion connector**

profiled connecting piece shaped to provide continuity between two length of hollow profile of a framing member (see [Figure A.2](#))

**3.28**

**splice sleeve**

connector between two neighbouring modules of unitized construction (see [Figure A.10](#))

**3.29**

**starting sill**

horizontal framing member positioned under the lowest module(s) in unitized construction that the module(s) clip(s) into (see [Figure A.10](#))

**3.30**

**stick construction**

carrier framework of site assembled components supporting glass, insulating glass units and infill panels (see [Figure A.5](#))

Note 1 to entry: Referred to as "stick curtain walling".

**3.31**

**thermal break**

element of low thermal conductivity incorporated into an assembly to reduce the flow of heat between more conductive materials (see [Figure A.2](#) and [Figure A.3](#))

**3.32**

**transom**

horizontal framing member of a curtain walling (see [Figure A.1](#), [Figure A.2](#) and [Figure A.3](#))

**3.33**

**transom connector**

**cleat**

profiled connector shaped for installation within the hollow cavity of a transom for connection to a mullion (see [Figure A.2](#))

Note 1 to entry: Term "shear block" is also used in some countries.

**3.34**

**unitised construction**

pre-assembled, interlinking, storey height or multi-storey height facade modules, complete with infill panels (see [Figure A.6](#))

Note 1 to entry: Referred to as "unitised curtain walling".

**3.35**

**vapour control layer  
vapour barrier**

layer comprising a material or coating with greater resistance to vapour transmission than the other layers of the wall and designed to control vapour movement through the wall

**3.36**

**vision area**

transparent zone of the curtain walling that admits daylight and allows visual communication through (see [Figure A.9](#))

Note 1 to entry: The vision area of curtain walling can be influenced by other parts of the building which act as obstacles, e.g. solid walls, screens, or viewing angle.



**Annex A**  
(informative)

**Illustration of the various defined terms**

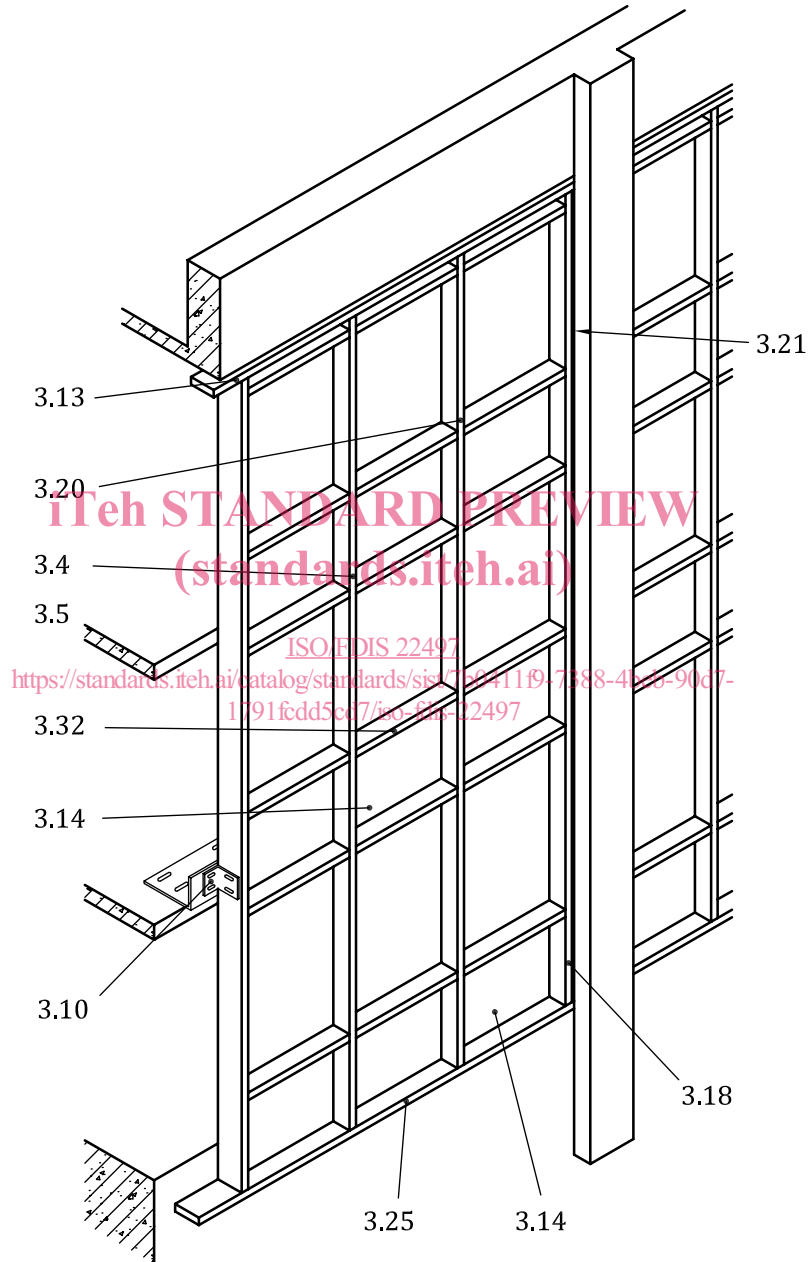

**Figure A.1 — Examples of components**

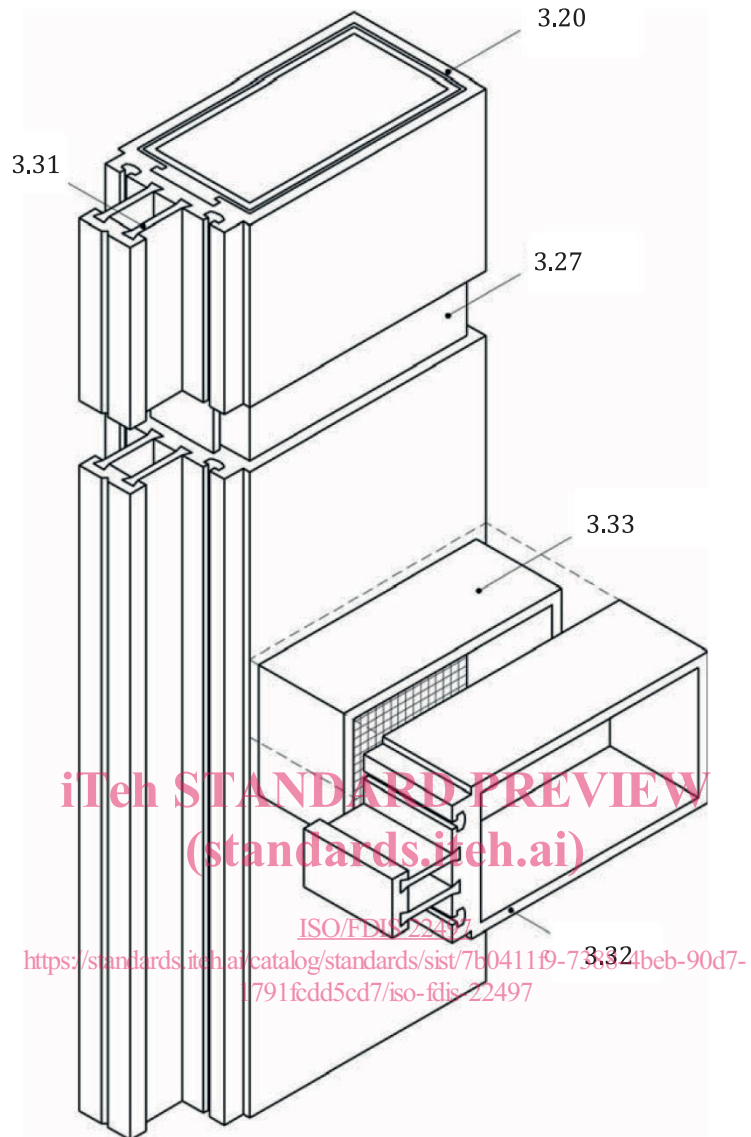

Figure A.2 — Examples of components

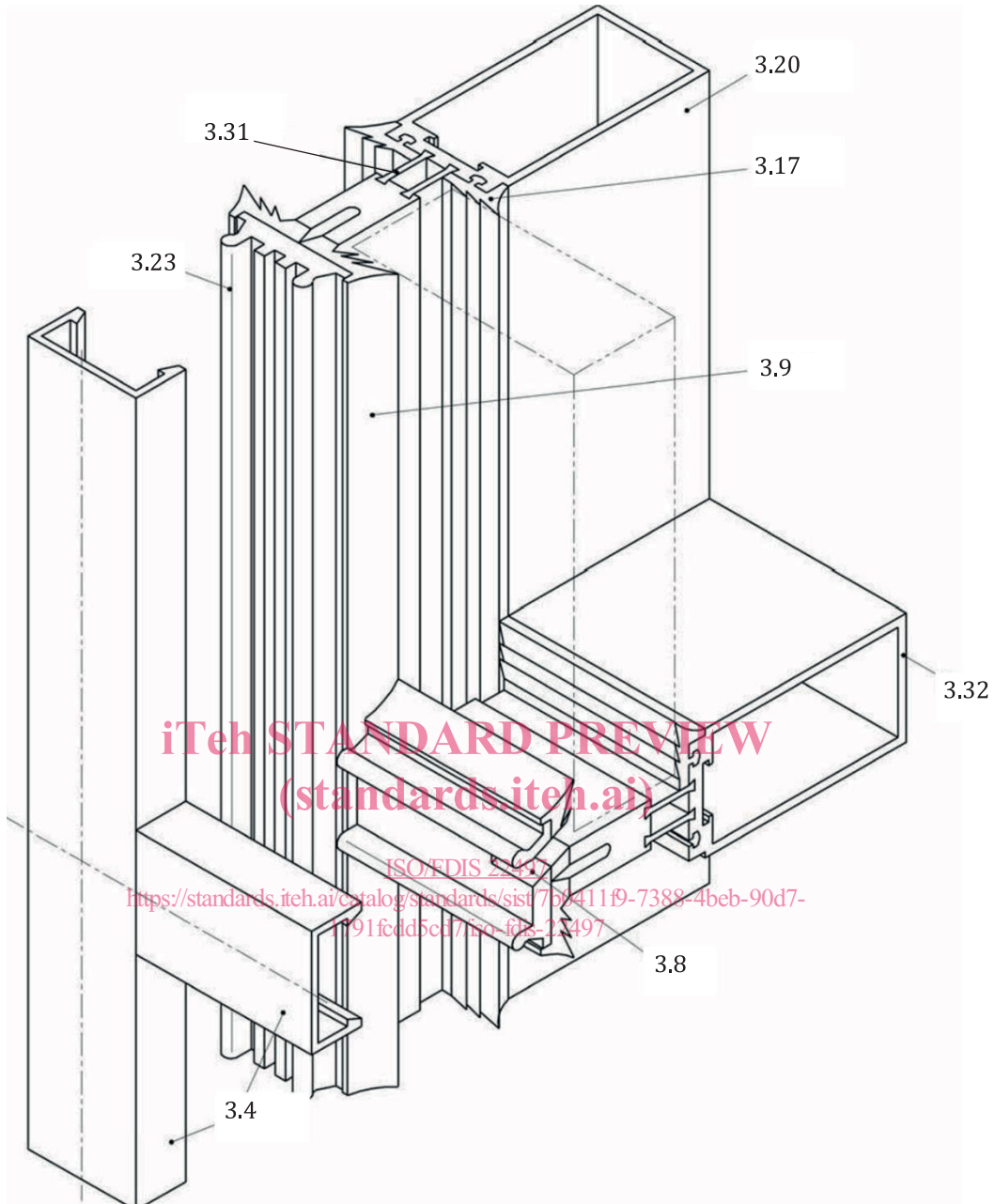

Figure A.3 — Examples of components