



Designation: ~~E636-09~~ Designation: E636 - 10

## Standard Guide for Conducting Supplemental Surveillance Tests for Nuclear Power Reactor Vessels, E 706 (IH)<sup>1</sup>

This standard is issued under the fixed designation E636; the number immediately following the designation indicates the year of original adoption or, in the case of revision, the year of last revision. A number in parentheses indicates the year of last reapproval. A superscript epsilon ( $\epsilon$ ) indicates an editorial change since the last revision or reapproval.

### 1. Scope

1.1 This guide discusses test procedures that can be used in conjunction with, but not as alternatives to, those required by Practices E185 and E2215 for the surveillance of nuclear reactor vessels. The supplemental mechanical property tests outlined permit the acquisition of additional information on radiation-induced changes in fracture toughness, notch ductility, and yield strength properties of the reactor vessel steels.

1.2 This guide provides recommendations for the preparation of test specimens for irradiation, and identifies special precautions and requirements for reactor surveillance operations and postirradiation test planning. Guidance on data reduction and computational procedures is also given. Reference is made to other ASTM ~~and ISO~~ test methods for the physical conduct of specimen tests and for raw data acquisition.

### 2. Referenced Documents

#### 2.1 *ASTM Standards:*<sup>2</sup>

E23 [Test Methods for Notched Bar Impact Testing of Metallic Materials](#)

E185 [Practice for Design of Surveillance Programs for Light-Water Moderated Nuclear Power Reactor Vessels](#)

E399 [Test Method for Linear-Elastic Plane-Strain Fracture Toughness  \$K\_{Ic}\$  of Metallic Materials](#)

E1253 [Guide for Reconstitution of Irradiated Charpy-Sized Specimens](#)

E1820 [Test Method for Measurement of Fracture Toughness](#)

E1921 [Test Method for Determination of Reference Temperature,  \$T\_0\$ , for Ferritic Steels in the Transition Range](#)

~~E2215 Practice for Evaluation of Surveillance Capsules from Light-Water Moderated Nuclear Power Reactor Vessels~~ [Practice for Evaluation of Surveillance Capsules from Light-Water Moderated Nuclear Power Reactor Vessels](#)

~~E2298 Test Method for Instrumented Impact Testing of Metallic Materials~~

#### 2.2 *Other Standards:* ~~ASME Standards:~~<sup>3</sup>

~~ASME Boiler and Pressure Vessel Code, Section III Subsection NB (Class 1 Components)~~

~~ISO 14556 Steel Charpy V-notch Pendulum Impact Test—Instrumented Test Method—Subsection NB (Class 1 Components)~~

### 3. Significance and Use

3.1 Practices E185 and E2215 describe a minimum program for the surveillance of reactor vessel materials, specifically mechanical property changes that occur in service. This guide may be applied in order to generate additional specific fracture toughness property information on radiation-induced property changes to better assist the determination of the optimum reactor vessel operation schemes.

### 4. Supplemental Mechanical Property Test

4.1 *Fracture Toughness Test*—This test involves the dynamic or static testing of a fatigue-precracked specimen during which a record of force versus displacement is used to determine material fracture toughness properties such as the plane strain fracture toughness ( $K_{Ic}$ ), the  $J$ -integral fracture toughness ( $J_{Ic}$ ), the  $J$ - $R$  curve, and the reference temperature ( $T_0$ ) (see Test Methods E399, E1820, and E1921, respectively). These test methods generally apply to elastic, ductile-to-brittle transition, or fully plastic behavior. The rate of specimen loading or stress intensity increase required for test classification as quasi-static or dynamic is indicated by the referenced test methods. All three test methods specify a lower limit on loading rate for dynamic tests.

<sup>1</sup> This guide is under the jurisdiction of ASTM Committee E10 on Nuclear Technology and Applications and is the direct responsibility of Subcommittee E10.02 on Behavior and Use of Nuclear Structural Materials.

Current edition approved Feb-March 1, 2009-2010. Published March 2009-April 2010. Originally approved in 1983. Last previous edition approved in 2002-2009 as E636 - 09. DOI: 10.1520/E0636-109.

<sup>2</sup> For referenced ASTM standards, visit the ASTM website, www.astm.org, or contact ASTM Customer Service at service@astm.org. For *Annual Book of ASTM Standards* volume information, refer to the standard's Document Summary page on the ASTM website.

<sup>3</sup> Available from American Society of Mechanical Engineers, 345 E. 47th St., New York, NY 10017.

4.2 *Fracture Toughness Test at Impact Loading Rates*—This test involves impact testing of Charpy V-notch specimens that have been fatigue precracked. A force versus deflection or time record, or both, is obtained during the test to determine an estimate of material dynamic fracture toughness properties. Currently, no standard test method is available for performing and analyzing this test; details on the recommended procedures are given in 7.1–7.4 and Appendix Appendix X1.

4.3 *Instrumented Charpy V-Notch Test*—This test involves the impact testing of standard Charpy V-notch specimens using a conventional tester (Test Methods E23) equipped with supplemental instrumentation that provides a force versus deflection or time record, or both, to augment standard test data (ISO 14556 (see Test Method E2298)). The test record is used primarily to estimate dynamic yield stress, fracture initiation and propagation energies, and to identify fully ductile (upper shelf) fracture behavior.

4.4 Other mechanical property tests not covered by ASTM standards, for example, miniature, nondestructive, nonintrusive, or in-situ testing techniques, can be utilized to accommodate limitations of material availability or irradiation facility configuration, or both. However, the user should establish the method's technical validity and correlation with existing test methods.

## 5. General Test Requirements

### 5.1 Specimen Orientation and Preparation:

5.1.1 *Orientation*—It is recommended that specimens for supplemental surveillance testing be taken from the quarter thickness location of plate and forging materials, as defined in NB 2300 of ASME Boiler and Pressure Vessel Code, Section III, and at a distance at least one material thickness from a quenched edge. Specimens from near surface material also may be considered for special studies, if required. For weld deposits, it is recommended that the specimens be taken from a thickness location at least 12.7 mm (½ in.) removed from the root and the surfaces of the weld. Consistent with Practice E185, it is further recommended that the specimens be oriented to represent the transverse orientation (T-L, per Test Method E399) in plate and forging materials. Specimens having the longitudinal orientation (L-T, per Test Method E399) also may be used given sufficient material and space in the surveillance capsule. For weld deposits, the specimen shall be oriented to make the plane of fracture parallel to the welding direction and perpendicular to the weldment surface, with the direction of crack growth along the welding direction. Examples of specimen orientations are given in Fig. 1.

5.1.1.1 *Specimen Notch Orientation* —The specimen notch root in all cases shall be oriented normal to the plate, forging, or weldment surface. For weld deposits, the notch also should be located at the approximate weld deposit centerline. The centerline and the width of the weld deposit about the notch shall be determined from the weld fusion lines revealed by etching. It is recommended that the location of the weld fusion lines be permanently marked for reference for post-irradiation testing. The general appearance of the etched weld deposit in terms of individual weld bead size (large vs. small) and the number of weld beads across the weld deposit should be determined and recorded.

5.1.1.2 *Specimen Marking*—A suitable specimen identification, marking, and documentation system shall be used whereby the location and orientation of each specimen within the source plate, forging, or weldment can be traced. The traceability of weld specimens is particularly important because of the possibility for variations through the weldment thickness.

5.1.2 *Preparation*—All specimens shall be prepared from material that has been fully heat-treated, including stress-relief annealing, as recommended in Practice E185.

5.1.2.1 *Reconstitution*—If reconstituted specimens are to be used, the procedures outlined in Guide E1253 shall be followed for Charpy-sized specimens. For other specimen geometries, it must have been previously proven that the reconstitution procedure has no significant influence on the test result.

5.1.2.2 *Machining*—Specimens for irradiation should be finish machined on all sides to aid encapsulation in reactor experiments and to aid radiation temperature control and uniformity.

5.1.2.3 *Fatigue Precracking*—It is recommended that fatigue precracking of specimens be accomplished prior to irradiation to avoid difficulties of precracking following irradiation. However, fatigue precracking of a specimen following irradiation is acceptable if a suitable means of following crack extension in the specimen is established.

5.1.2.4 *Fatigue Precracking of Postirradiation Heat-Treated Specimens*—Some postirradiation heat treatments at temperatures higher than the prior irradiation exposure can cause mechanical property recovery, including reductions in yield strength and tensile strength and an improvement in fracture toughness toward preirradiation levels. Compliance with Test Methods E399, E1820, and E1921 requires that fatigue precracking be accomplished in the final heat treatment condition. This may be impractical for irradiated specimens. Fatigue precracking before postirradiation heat treatment is acceptable for low temperature heat treatment typical of reactor vessel annealing. It is believed that fatigue precracking of ferritic material specimens prior to heat treatment below 482°C (900°F) does not alter the test results for the bulk material properties as intended.

### 5.2 Specimen Irradiation:

5.2.1 *General*—The recommendations of Practice E185 concerning the encapsulation of specimens, temperature and neutron fluence monitoring, and irradiation exposure conditions should be followed. The larger size of some supplemental test specimens may require additional consideration of temperature gradients and neutron flux gradients within individual specimens and within the specimen capsules.

5.2.2 *Specimen Irradiation*—Supplemental test specimens may be irradiated in the same capsule as the specimens required by Practice E185 when supplemental results are desired.

### 5.3 Specimen Handling and Remote Test Equipment:

5.3.1 *General*—For testing in a controlled area or in a hot cell facility, remote devices for accurately positioning the specimen

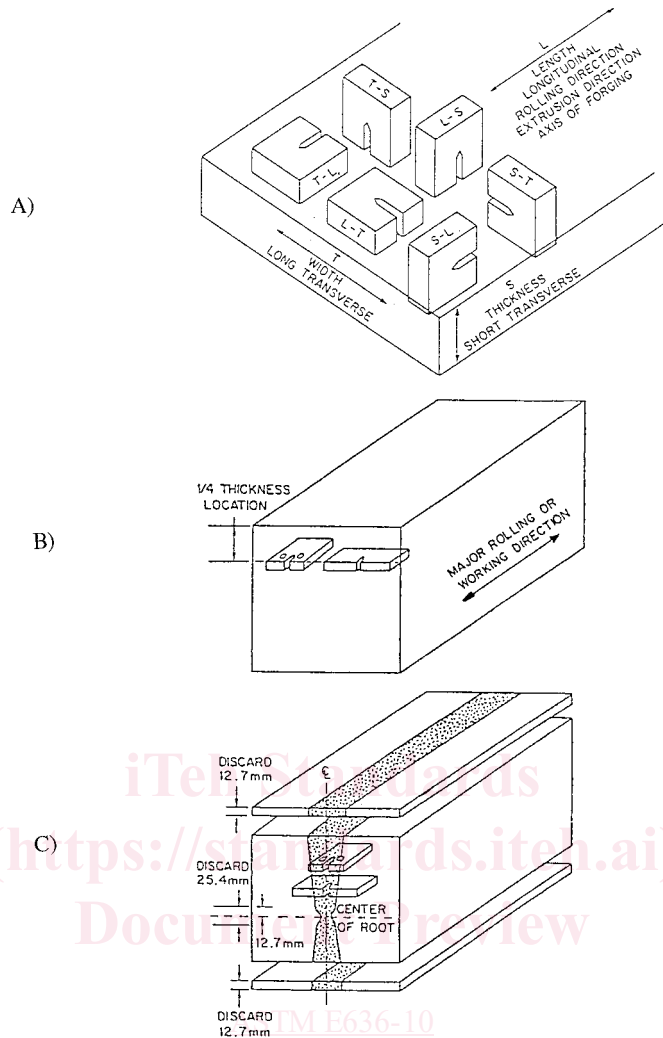

**FIG. 1 Specimen Orientation and Location in Plate, Forging, and Weld Deposit Materials: A) Crack Plane Orientation Code; B) Plate and Forging Specimen Location and Orientation; C) Weld Specimen Location and Orientation**

in the test machine are generally required. For notched or precracked Charpy impact specimens, automatic devices to position the specimen on the test anvils are strongly recommended. Additional remote devices for specimen heating and cooling and for the attachment of measuring fixtures are also necessary. Remote testing equipment shall satisfy the tolerances and accuracy requirements of the applicable ASTM standards for the test method(s) employed.

5.4 *Specimen Testing*—It is recommended that postirradiation Charpy V-notch impact and tensile tests be performed in accordance with Practice E2215 prior to supplemental specimen testing to establish a basis for selecting test temperatures for the supplemental specimens tested under this method.

5.5 *Documentation:*

5.5.1 The report shall include the reporting requirements on material identification and irradiation history required by Practice E185. Emphasis should be placed on the reporting of tensile properties with fracture toughness test results. See 6.1.3.2).

5.5.2 Names and models of testing and monitoring equipment, and the accuracy to which they operate, will be reported. Any special modifications (for example, force damping equipment, etc.) to the testing equipment must be indicated. Pertinent testing procedures used also shall be reported.

5.5.3 To aid in the interpretation of these supplemental surveillance results, data developed in accordance with Practice E2215, including data from reference correlation monitor material or data from other supplemental surveillance mechanical property tests, should be included in the report or should be referenced suitably.

5.5.4 If reconstituted specimens have been used, information concerning the reconstitution technique shall be given in accordance with Guide E1253.

**6. Fracture Toughness Test**

6.1 *Specimen Design and Possible Modifications:*

6.1.1 *Specimen*—The compact, single-edge bend or disk-shaped compact specimen of dimensions outlined in Test Method E399, Test Method E1820, or Test Method E1921, allowing for design modification (see 6.1.2) for surveillance capsules, will be used for testing.

6.1.2 *Possible Design Modification* —Modified specimens are useful when test stock or irradiation space is limited, or when gamma heating or neutron flux gradients must be minimized. An example of reconstituted Charpy-type specimen is illustrated in Fig. 2. Specimens have also been modified after irradiation to improve their measuring capabilities. For example, many early pressurized water reactors (PWR) contain wedge-opening loaded (WOL) fracture mechanics specimens. These specimens were originally intended for testing in the brittle fracture regimen. For ductile materials, bending can occur in the loading arms of these specimens and the tests become invalid. However, techniques have been developed to make these specimens useful for testing under ductile conditions. These include extension of the fatigue precrack or modification of the specimen dimensions, or both (1).<sup>4</sup> Modified specimen designs may be employed for irradiation provided that it is shown in advance that their use will not significantly diminish the accuracy of the test or alter test results; if correlations with standard specimen test results have to be employed, their justification and accuracy have to be provided.

6.1.2.1 The pinhole spacings for compact specimens recommended in Test Method E399 and Test Methods E1820 or E1921 are different. However, this difference does not significantly affect the stress field at the crack tip and, therefore, either pinhole spacing is acceptable for surveillance testing (2).

6.1.3 *Fatigue Precracking*—Fatigue precracking shall be performed in accordance with either Test Method E399, Test Method E1820, or Test Method E1921 as discussed in 6.1.3.1-6.1.3.3.

6.1.3.1 *Elastic and Elastic-Plastic Fracture Behavior*—When testing is expected to be performed at temperatures where the specimen ultimately fractures by cleavage, the crack size-to-width ratio,  $a/W$ , should range between 0.45 and 0.55, and precracking should be accomplished in accordance with Test Method E399 or Test Method E1921.

6.1.3.2 *Fully Plastic Behavior*—When testing is expected to be performed in the region characteristic of fully plastic fracture behavior, compliance with Test Method E1820 requires the  $a/W$  ratio to be between 0.45 and 0.70 and that the specimen thickness,  $B$ , and the initial remaining ligament,  $b_o$ , be greater than the value of  $J_o/25 \sigma_{flow}$ , where  $J_o$  is a provisional value of  $J_{Ic}$ , the plane-strain fracture toughness near the onset of stable crack extension, and  $\sigma_{flow}$  is the average of the yield strength and the tensile strength of the material at the test temperature.

6.1.3.3  *$a/W$  ratio*—It is noted that  $a/W$  values between 0.45 and 0.55 will comply with both the requirements of Test Methods E399 and E1921 for testing elastic and ductile-to-brittle transition fracture behavior (see 6.1.3.1) and Test Method E1820 for testing fully plastic behavior (see 6.1.3.2).

6.2 *Special Requirements for Surveillance Application*—For a given neutron exposure level, the minimum number of specimens to be tested and the choice of test temperatures in relation to the expected fracture behavior are normally given in the relevant Test Methods.

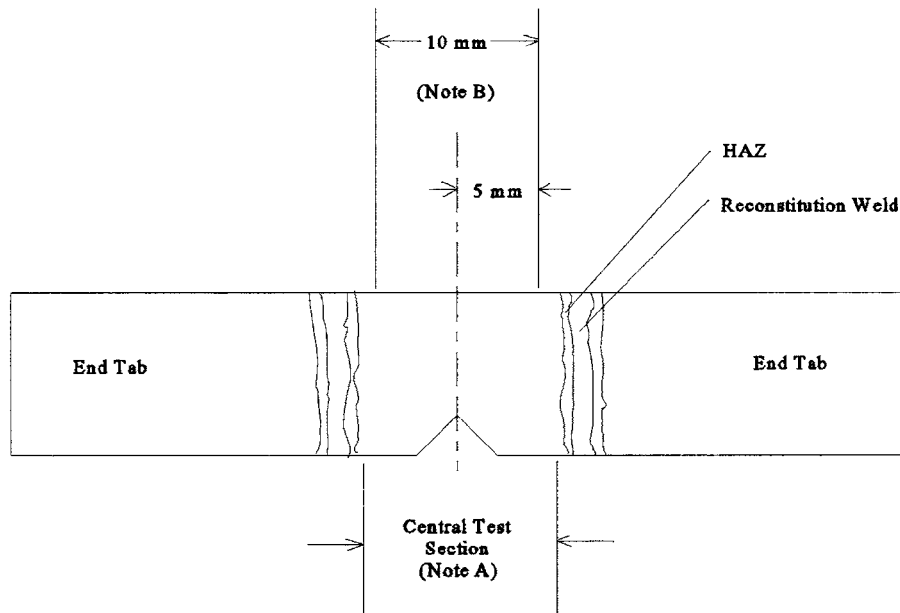

FIG. 2 Example of Reconstituted Charpy-type Specimen

NOTE 1—The specimens for characterization of elastic fracture behavior need not be of the same thickness as those required for transition or fully plastic fracture behavior. See Test Methods E399, E1820, and E1921 for size requirements.

6.2.1 *Tensile Data*—0.2 % offset yield and ultimate tensile strength properties for the material are required for the evaluation of fracture toughness test results.

6.2.2 *Postirradiation Preparation of Specimens*:

6.2.2.1 If end-tab welding (compound specimens) is to be performed (see Fig. 2), it must be verified that the temperature in the test region does not reach or exceed the irradiation temperature. Additionally, the procedure should minimize residual stresses that will affect the experimental results. To minimize the temperature in the notch region during welding, electron beam welding (two passes per weld, one on each side of the specimen) and the use of copper chill blocks are recommended. The irradiated material shall be of sufficient size to fully contain the plastic zone developed at maximum force. For information about determining the dimensions of irradiated material see Refs (6(3) and (7(4)). A compound specimen fabrication procedure should not be used unless previously proven to have no significant influence on the fracture toughness test result.

6.2.2.2 If additional fatigue crack extension is performed after irradiation, the conditions outlined in 6.1.3 should be satisfied.

6.2.2.3 Side grooving of specimens, if required, may be performed after irradiation but should be performed following final fatigue crack extension.

6.2.3 *Postirradiation Specimen Testing*—If the recommendations of 6.2 on the sufficiency of test specimens cannot be satisfied, a decision on testing priorities will have to be made taking into consideration the results of the surveillance program described in Practice E185 and other available information.

6.2.3.1 *Test Temperature Selection* —If fracture toughness properties in the transition region are of greatest need for measurements and correlations with the radiation-induced Charpy V-notch 41-J-40.7-J temperature shift, tests should be selected to define the reference temperature  $T_{0r}$  at which the median of the fracture toughness ( $K_{Jc}$ ) distribution from IT size specimens will equal  $100 \text{ MPa} \sqrt{m}$  ( $91 \text{ ksi} \sqrt{\text{in.}}$ ). If fracture toughness in the fully plastic behavior region is of greatest need,  $J$ -integral tests should be performed at temperatures effecting fully plastic fracture behavior in the specimen.

6.2.3.2 *Loading Rates*—The limits that define a conventional (quasi-static) test are specified in Test Methods E399, E1820 and E1921 in case of elastic, elastic-plastic or fully plastic behavior, respectively.

6.3 *Data Development and Computational Procedures*:

6.3.1 *Elastic Behavior*—Test Method E399 data development methods, computational procedures, and test validity criteria are to be applied for fully elastic test behavior.

6.3.2 *Ductile-to-Brittle Transition Behavior*—Test Method E1921 data development methods, computational procedures, and test validity criteria are to be applied for ductile-to-brittle transition test behavior.

6.3.3 *Plastic Behavior*—The  $J$ -integral method or the  $J$ - $R$  curve technique, or both, shall be applied as appropriate for the computation of fracture toughness when the material demonstrates fully plastic fracture behavior (Test Methods E1820).

6.4 *Report*:

6.4.1 *Data*—In addition to the reporting requirements of 5.5 and Test Methods E399, E1820, and E1921, the following shall be reported: force-deflection curve, specimen type and dimensions, method and location of displacement measurements, test temperature, specimen identification and orientation, measured fatigue precrack size, amount of stable ductile tearing, and specimen loading rate (or stress-intensity rate). The validity criteria, the calculated fracture toughness, and the analytical method used also shall be reported. Specimen precracking records, original force-time curves, temperature records, analytical calculations, and photographs of the fracture surfaces of the broken specimens shall be kept on record by the test facility.

6.4.2 *Modified Specimen Reporting* —In addition to the reporting requirements of 6.4.1, when (reconstituted) specimens or other modified specimen types have been tested, the test specimen design shall be supplied.

## 7. Fracture Toughness Test at Impact Loading Rates

7.1 Presently, no test standard is available for the execution and analysis of fracture toughness tests at impact loading rates on precracked Charpy specimens. Nevertheless, extensive literature is available on this topic Refs (3-93-9); what follows is intended to provide guidance to the user, based on the most widely used experimental and analysis procedures.

7.2 *Specimen*:

7.2.1 *Design*—The nominal dimensions and configuration of the specimen are given in Test Methods E23 (Charpy Type A). The machined notch is extended (precracked) by fatigue cycling. Side grooving after precracking is optional.

7.2.2 *Fatigue Precracking*—The specimen shall be fatigue precracked to provide an  $a/W$  ratio between 0.30 and 0.70. If the results in terms of  $J$  or  $\delta$  are to be directly comparable to full-size standard fracture toughness values determined in accordance with Test Methods E1820, Annexes A8-A12,  $a/W$  shall be in the range  $0.45 < a/W < 0.70$ . If the results in terms of  $K_{Jc}$  are to be directly comparable to full-size standard fracture toughness values determined in accordance with Test Method E1921,  $a/W$  shall be in the range of  $0.45 < a/W < 0.55$ . Otherwise, shorter crack lengths ( $0.30 < a/W < 0.45$ ) may be more advantageous. Fatigue precracking will be in accordance with Test Methods E1820 or E1921 in accordance with the parameter to be determined (that is,  $J/\delta$  or  $K_{Jc}$ ).

7.3 *Special Requirements for Surveillance Applications*—For a given neutron exposure level and material condition, a minimum of eight specimens shall be tested in order to define the brittle/ductile transition. Ten specimens are recommended (two in addition to the eight tested) in the event retests are required.

7.3.1 *Postirradiation Specimen Preparation, Fatigue Precracking*—If fatigue precracking is performed after irradiation, the limits established in 7.2.2 shall not be exceeded.

7.3.2 *Specimen Testing Equipment* —The force measuring system (instrumented striker, amplifier, recording system) shall have a response of at least 100 kHz, which corresponds to a rise time ( $t_r$ ) of no more than 3.5  $\mu\text{s}$  (~~ISO-14556~~)- $\mu\text{s}$ . Furthermore, the test should satisfy the following constraints:

Damping Inertia Effects  
Available Energy Criterion

$$t^* \geq 3\tau$$

$$W_0 \geq 3W_m$$

E0636-09-3

where:

$t^*$  = time to general yield force or specimen failure,

$\tau$  = period of the apparent specimen oscillation about the actual force ( $\tau$  is typically 40  $\mu\text{s}$  for a reactor vessel steel precracked Charpy specimen),

$W_0$  = total available energy of the pendulum during impact loading, and

$W_m$  = energy corresponding to maximum force.

### 7.3.3 *Postirradiation Specimen Testing:*

7.3.3.1 *Test Temperature Selection* —Test temperatures should be chosen to enable assessment of the brittle/ductile transition region. The initial test temperature should coincide with the lower knee of the transition region determined from standard Charpy V-notch tests conducted in accordance with Practice E2215.

7.3.3.2 *Stress Intensity Rates During Loading*—The initial loading rate should be  $1.1 \times 10^3 \text{ MPa } \sqrt{m} / \text{s}$  ( $10^3 \text{ ksi } \sqrt{\text{in.}} / \text{s}$ ) or greater. A typical loading rate for impact testing of precracked Charpy specimens is  $3.3 \times 10^5 \text{ MPa } \sqrt{m} / \text{s}$ . Upper and lower limits on loading rates are set by the inertial effects damping criterion ( $t^* \geq 3\tau$ ) and the energy criterion ( $W_0 \geq 3W_m$ ), respectively ~~(3(5))~~.

7.3.3.3 *Test Record*—For each precracked Charpy test, a force vs. deflection or time record, or both, shall be generated. Fatigue crack size shall be measured in accordance with Test Methods E1820.

7.3.3.4 *Data Acquisition Equipment* —Dynamic data acquisition is best accomplished using digital acquisition equipment. For these tests, data acquisition rates of the equipment should be capable of capturing at least one data point every two microseconds.

### 7.4 *Data Development and Computation Procedures:*

7.4.1 *Elastic and Elastic-Plastic Behaviors*—An ASTM standard method for determining dynamic fracture toughness for elastic and elastic-plastic (fracture occurs after general yielding) fracture behavior is not yet available for impact loading. A procedure used to calculate the dynamic stress intensity factor from the energy absorbed up to specimen fracture is given in Appendix X1. These values may be analyzed using the Master Curve approach of Test Method E1921 in order to determine a dynamic value of the reference temperature. Refs ~~(3-83-9)~~ provide additional information on the data development methods, computational procedures, and test validity criteria.

7.5 *Report*—The following information shall be obtained and reported in addition to the reporting requirements of 5.5.

7.5.1 *Test Record*—In addition to material documentation, the following shall be reported: specimen identification, orientation and dimensions, fatigue crack size, fracture appearance, test temperature, loading rate, dynamic stress intensity factor, and methods of analysis.

7.5.2 *Test Validity*—All validity criteria utilized and the degree to which they are met by the tests performed will be reported.

7.5.3 *Laboratory Records*—Records to be maintained by the testing organization are specimen force-deflection or force-time test data, or both, methods of temperature conditioning and control, precracking method and parameters, and analytical calculations.

## 8. Instrumented Charpy V-Notch Impact Test

8.1 *Specimen Design*—The standard Charpy V-Notch Impact Test Specimen, Type A, as described in Test Methods E23, shall be used.

### 8.2 *Special Requirements for Surveillance Applications:*

8.2.1 *Specimen Requirements*—Specimens prepared in accordance with Practices E185 and E2215 are tested by this optional method to obtain supplemental information.

8.2.2 *Special Equipment*—The method requires certain special equipment: an instrumented striker (~~tip~~) on the impact tester and an instrument package capable of recording force-time information during the deformation and fracture of the specimen.

8.2.2.1 The force measuring system (instrumented striker, amplifier, recording system) shall have a response of at least 100 kHz, which corresponds to a rise time ( $t_r$ ) of no more than 3.5  $\mu\text{s}$  (~~ISO-14556~~)-(Test Method E2298).

### 8.2.3 *Specimen Testing:*

8.2.3.1 *Test Temperatures*—No special requirements other than those of Practices E185 and E2215 are specified.

8.2.3.2 *Test Records*—Force versus time records, and the velocity and kinetic energy of the ~~tip~~ instrumented striker immediately before impact provide the basic raw data. An example of an actual force-time record is given in Fig. 3 -(Test Method E2298). Fig. 4 represents an idealized force-deflection record obtained by analysis of the force-time data from an instrumented Charpy V-notch test (~~ISO-14556~~) at a temperature corresponding to the mid-energy transition region. At lower temperatures, fracture occurs at shorter times and may preclude general yielding. The curve is schematic; the normal oscillations of force have been smoothed out.