

INTERNATIONAL
STANDARD

ISO
17231

IULTCS/IUP 37

Second edition
2017-08

**Leather — Physical and mechanical
tests — Determination of water
repellency of garment leather**

*Cuir — Essais physiques et mécaniques — Détermination de la
résistance au mouillage superficiel des cuirs pour vêtements*

iTeh STANDARD PREVIEW
(standards.iteh.ai)

[ISO 17231:2017](https://standards.iteh.ai/catalog/standards/sist/44acecbb-a3b9-479e-88bd-af5cb04f27f5/iso-17231-2017)

<https://standards.iteh.ai/catalog/standards/sist/44acecbb-a3b9-479e-88bd-af5cb04f27f5/iso-17231-2017>



Reference numbers
ISO 17231:2017(E)
IULTCS/IUP 37:2017(E)

© ISO 2017

iTeh STANDARD PREVIEW (standards.iteh.ai)

ISO 17231:2017

<https://standards.iteh.ai/catalog/standards/sist/44acecbb-a3b9-479e-88bd-af5cb04f27f5/iso-17231-2017>



COPYRIGHT PROTECTED DOCUMENT

© ISO 2017, Published in Switzerland

All rights reserved. Unless otherwise specified, no part of this publication may be reproduced or utilized otherwise in any form or by any means, electronic or mechanical, including photocopying, or posting on the internet or an intranet, without prior written permission. Permission can be requested from either ISO at the address below or ISO's member body in the country of the requester.

ISO copyright office
Ch. de Blandonnet 8 • CP 401
CH-1214 Vernier, Geneva, Switzerland
Tel. +41 22 749 01 11
Fax +41 22 749 09 47
copyright@iso.org
www.iso.org

Contents

	Page
Foreword	iv
1 Scope	1
2 Normative references	1
3 Terms and definitions	1
4 Principle	1
5 Apparatus	1
6 Sampling and sample preparation	3
7 Procedure	3
8 Expression of results	4
9 Test report	4
Annex A (normative) ISO photographic scale	6
Annex B (informative) Sources of apparatus	7

iTeh STANDARD PREVIEW (standards.iteh.ai)

<https://standards.iteh.ai/catalog/standards/sist/44acecbb-a3b9-479e-88bd-af5cb04f27f5/iso-17231-2017>

Foreword

ISO (the International Organization for Standardization) is a worldwide federation of national standards bodies (ISO member bodies). The work of preparing International Standards is normally carried out through ISO technical committees. Each member body interested in a subject for which a technical committee has been established has the right to be represented on that committee. International organizations, governmental and non-governmental, in liaison with ISO, also take part in the work. ISO collaborates closely with the International Electrotechnical Commission (IEC) on all matters of electrotechnical standardization.

The procedures used to develop this document and those intended for its further maintenance are described in the ISO/IEC Directives, Part 1. In particular the different approval criteria needed for the different types of ISO documents should be noted. This document was drafted in accordance with the editorial rules of the ISO/IEC Directives, Part 2 (see www.iso.org/directives).

Attention is drawn to the possibility that some of the elements of this document may be the subject of patent rights. ISO shall not be held responsible for identifying any or all such patent rights. Details of any patent rights identified during the development of the document will be in the Introduction and/or on the ISO list of patent declarations received (see www.iso.org/patents).

Any trade name used in this document is information given for the convenience of users and does not constitute an endorsement.

For an explanation on the voluntary nature of standards, the meaning of ISO specific terms and expressions related to conformity assessment, as well as information about ISO's adherence to the World Trade Organization (WTO) principles in the Technical Barriers to Trade (TBT) see the following URL: www.iso.org/iso/foreword.html (standards.iteh.ai)

This document was prepared by the Physical Test Commission of the International Union of Leather Technologists and Chemists Societies (IUP Commission, IULTCS) in collaboration with the European Committee for Standardization (CEN) Technical Committee CEN/TC 289, *Leather*, the secretariat of which is held by UNI, in accordance with the Agreement on technical cooperation between ISO and CEN (Vienna Agreement).

It is based on IUP 37 published in *J. Soc. Leather Tech. Chem.*, **86**(7), p. 339, 2002, and declared an official method of the IULTCS in May 2003.

IULTCS, originally formed in 1897, is a world-wide organization of professional leather societies to further the advancement of leather science and technology. IULTCS has three Commissions, which are responsible for establishing international methods for the sampling and testing of leather. ISO recognizes IULTCS as an international standardizing body for the preparation of test methods for leather.

This second edition replaces the first edition, ISO 17231:2006. Editorial changes have been made to [Clauses 5, 7, 9a, 9e, Annex A](#) and [Annex B](#).

Leather — Physical and mechanical tests — Determination of water repellency of garment leather

1 Scope

This document specifies a method for determining the repellency of leather to surface wetting. It is applicable to all leathers intended for use in clothing. The method does not determine the resistance of leather to water penetration.

2 Normative references

The following documents are referred to in the text in such a way that some or all of their content constitutes requirements of this document. For dated references, only the edition cited applies. For undated references, the latest edition of the referenced document (including any amendments) applies.

ISO 2418, *Leather — Chemical, physical and mechanical and fastness tests — Sampling location*

ISO 2419, *Leather — Physical and mechanical tests — Sample preparation and conditioning*

ISO 3696, *Water for analytical laboratory use — Specification and test methods*

3 Terms and definitions (standards.iteh.ai)

For the purposes of this document, the following terms and definitions apply.

ISO and IEC maintain terminological databases for use in standardization at the following addresses:

- ISO Online browsing platform: available at <http://www.iso.org/obp>
- IEC Electropedia: available at <http://www.electropedia.org/>

3.1

spray rating

measure of the resistance of the surface of a leather to wetting

4 Principle

A specified volume of distilled or deionized water is sprayed onto a test piece, which has been mounted on a ring and placed at an angle of 45° so that the centre of the test piece is at a specified distance below the spray nozzle. The spray rating is determined by comparing the appearance of the test piece with descriptive and photographic standards. The mass of water absorbed by the test piece is determined by weighing before and after applying the water spray.

5 Apparatus

5.1 **Test machine**, including the parts described in 5.2 to 5.4.

NOTE An example of a suitable apparatus available commercially is given in Annex B.

5.2 **Spray device**, as shown in Figure 1, consisting of a funnel, diameter 150 mm ± 2 mm, held vertically with a metal spray nozzle (5.3) connected to the end of the stem by flexible tubing of bore about 10 mm. The overall distance from the top of the funnel to the bottom of the nozzle is 190 mm ± 2 mm.

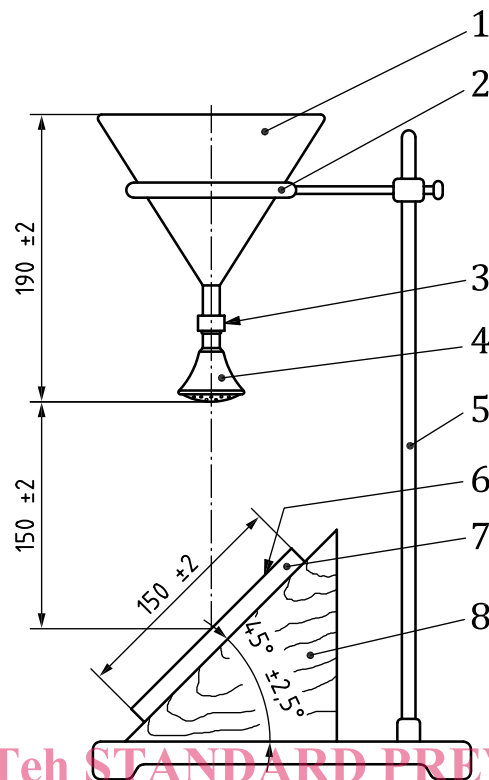

iTeh STANDARD PREVIEW
(standards.iteh.ai)

Key

- 1 glass funnel \varnothing 150 \pm 2
- 2 ring support
- 3 rubber tubing
- 4 spray nozzle
- 5 stand
- 6 specimen
- 7 specimen holder
- 8 support (e.g. wood)

ISO 17231:2017
<https://standards.iteh.ai/catalog/standards/sist/44acecbb-a3b9-479e-88bd-af5cb04f27f5/iso-17231-2017>

Figure 1 — Apparatus for spray test

5.3 Metal spray nozzle, as shown in [Figure 2](#), with approximate diameter of 33 mm, having a convex face with 19 holes of 0,9 mm \pm 0,05 mm diameter distributed over the face of the nozzle. The duration of flow for 250 ml \pm 5 ml of distilled or deionized water poured into the funnel shall be 27,5 s \pm 2,5 s.

Dimensions in millimetres

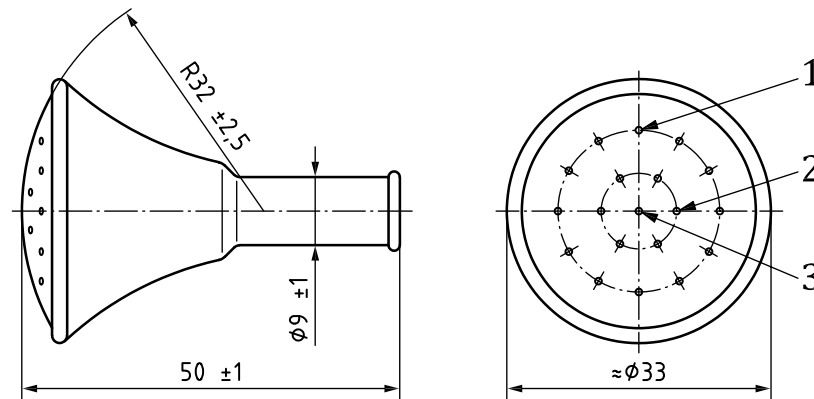

Key

- 1 12 holes $\varnothing 0,9 \pm 0,05$ on a circle $\varnothing 21,4 \pm 0,05$
- 2 6 holes $\varnothing 0,9 \pm 0,05$ on a circle $\varnothing 10 \pm 0,05$
- 3 1 hole $\varnothing 0,9 \pm 0,05$ on centre

Figure 2 — Spray nozzle

5.4 Test piece holder, consisting of two metal rings which fit into each other. The inner ring is fixed, with an outside diameter of $150 \text{ mm} \pm 2 \text{ mm}$. The outer ring is adjustable so that the internal diameter can be reduced to 150 mm to allow the test piece to be securely clamped between the two rings. When in position for testing, the rings rest on a suitable support so that the test piece is at an angle of $45,0^\circ \pm 2,5^\circ$, with the centre of the clamped area $150 \text{ mm} \pm 2 \text{ mm}$ below the centre of the face of the metal nozzle.

ISO 17231:2017

5.5 Balance, reading to $0,001 \text{ g}$. <https://www.iso.org/obp/ui/#iso:code:37:00:17231:2017>

5.6 Distilled or deionized water, conforming to the requirements of grade 3 of ISO 3696.

6 Sampling and sample preparation

6.1 Sample in accordance with ISO 2418. Cut three square test pieces of side $182 \text{ mm} \pm 2 \text{ mm}$ ensuring that they are taken from areas free from any holes or other damage.

NOTE 1 It may be necessary to trim the wool if a woolled sheepskin is being tested to allow secure clamping of the test piece.

NOTE 2 If there is a requirement for more than two hides or skins to be tested in one batch, then only one sample need be taken from each hide or skin, provided that the overall total is not less than three test pieces.

6.2 Condition the test pieces in accordance with ISO 2419.

6.3 Weigh the test piece to the nearest $0,001 \text{ g}$.

6.4 Carry out all further operations at a temperature of $20^\circ \text{C} \pm 2^\circ \text{C}$ or $23^\circ \text{C} \pm 2^\circ \text{C}$. There is no need for further humidity control.

7 Procedure

7.1 Mount the test piece securely on the test piece holder (5.4) with the face of the leather which would be exposed in wear uppermost. Place the test piece holder in position below the spray nozzle.

7.2 Pour 250 ml ± 5 ml of distilled or deionized water (5.6) at the controlled temperature (6.4) into the funnel quickly but steadily so that the spraying is continuous once it has commenced.

7.3 Immediately after the spraying has ceased, remove the holder and test piece and tap two diametrically opposite points of the frame against a solid object, with the plane of the leather almost horizontal and the tested surface downwards.

7.4 Assign to the test piece the spray rating on either the following descriptive scale or the photographic scale in Annex A which best describes the degree of wetting. Intermediate ratings are not to be attempted.

- 1) Wetting of the whole of the sprayed surface.
- 2) Wetting of half of the sprayed surface. This usually occurs through the merging of small, discrete wetted areas.
- 3) Wetting of the sprayed surface only as small discrete areas.
- 4) No wetting of, but adherence of small drops to, the sprayed surface.
- 5) No wetting of and no adherence of small drops to the sprayed surface.

7.5 Examine the reverse side of the test piece and note any wetting.

7.6 Remove the test piece from the holder, blot gently to remove any water droplets which still adhere and re-weigh to the nearest 0,001 g.

8 Expression of results

Calculate the mass of water absorbed, m_w , in grams and the percentage of water absorbed, w , using the equations:

$$m_w = m_2 - m_1$$

$$w = \frac{(m_2 - m_1)}{m_1} \times 100 \%$$

where

m_1 is the initial mass of the test piece, in grams;

m_2 is the mass of the test piece after the test, in grams.

9 Test report

The test report shall include the following for each test piece:

- a) a reference to this document; i.e. ISO 17231;
- b) the spray rating (7.4);
- c) the mass of water absorbed, m_w , in grams;
- d) the percentage of water absorbed, w ;
- e) the standard atmosphere used for conditioning and testing as given in ISO 2419;
- f) any deviations from the method specified in this document;

- g) full details for identification of the sample and any deviations from ISO 2418 with respect to sampling.

iTeh STANDARD PREVIEW
(standards.iteh.ai)

[ISO 17231:2017](https://standards.iteh.ai/catalog/standards/sist/44acecbb-a3b9-479e-88bd-af5cb04f27f5/iso-17231-2017)

<https://standards.iteh.ai/catalog/standards/sist/44acecbb-a3b9-479e-88bd-af5cb04f27f5/iso-17231-2017>