



Designation: D2625 – 94(Reapproved 2010)

## Standard Test Method for Endurance (Wear) Life and Load-Carrying Capacity of Solid Film Lubricants (Falex Pin and Vee Method)<sup>1</sup>

This standard is issued under the fixed designation D2625; the number immediately following the designation indicates the year of original adoption or, in the case of revision, the year of last revision. A number in parentheses indicates the year of last reapproval. A superscript epsilon ( $\epsilon$ ) indicates an editorial change since the last revision or reapproval.

*This standard has been approved for use by agencies of the U.S. Department of Defense.*

### 1. Scope

1.1 This test method (see [Note 1](#)) covers the determination of the endurance (wear) life and load-carrying capacity of dry solid film lubricants in sliding steel-on-steel applications.

NOTE 1—Reference may be made to Coordinating Research Council, Inc. (CRC) Report No. 419, “Development of Research Technique for Measuring Wear Life of Bonded Solid Lubricant Coatings for Airframes, Using the Falex Tester.” See also Military Specification MIL-L-8937 (ASG), Jan. 22, 1963, and Methods 3807 and 3812 of Federal Test Method 791a.

1.2 The values stated in SI units are to be regarded as the standard except where equipment is supplied using inch-pound units and would then be regarded as standard. The metric equivalents of inch-pound units given in such cases in the body of the standard may be approximate.

1.3 *This standard does not purport to address all of the safety concerns, if any, associated with its use. It is the responsibility of the user of this standard to establish appropriate safety and health practices and determine the applicability of regulatory limitations prior to use.*

### 2. Referenced Documents

#### 2.1 ASTM Standards:<sup>2</sup>

[B16/B16M Specification for Free-Cutting Brass Rod, Bar and Shapes for Use in Screw Machines](#)

[F22 Test Method for Hydrophobic Surface Films by the Water-Break Test](#)

#### 2.2 U.S. Military Specifications:<sup>3</sup>

[MIL-L-8937](#)

[MIL-P-16232F Phosphate Coatings, Heavy, Manganese or Zinc Base \(for Ferrous Metals\)](#)

#### 2.3 Other Standards:<sup>4</sup>

[42USC7671a Clean Air Act Amendments of 1990 Federal Test Method 791a Methods 3807 and 3812](#)

### 3. Terminology

#### 3.1 Definitions:

3.1.1 *dry solid film lubricants*—dry coatings consisting of lubricating powders in a solid matrix bonded to one or both surfaces to be lubricated.

#### 3.2 Definitions of Terms Specific to This Standard:

3.2.1 *direct load, n*—the load that is applied linearly, bisecting the angle of the vee block corrected to either the 800-lbf (3550-N) gauge reference or the 3000-lbf (13 300-N) gauge reference.

3.2.1.1 *Discussion*—This load is equivalent to the true load times the  $\cos 42^\circ$ .

3.2.2 *endurance (wear) life*—the length of test time before failure under a constant loaded condition, in minutes, in which the applied test lubricant performs its function.

3.2.3 *gauge load, n*—the value obtained from the gauge while running the test after being corrected to the standard curve using the calibration procedure for the 4500-lbf (20 000-N) reference gauge.

3.2.3.1 *Discussion*—The gauge reading is irrespective of the particular gauge used, and corrections are made by comparison to the Brinell ball impression diameters on a standard reference copper test coupon with a Rockwell hardness range of HB 37 to HB 39. An electronic calibration instrument<sup>5</sup> is available which can be used in place of the copper coupon.

<sup>1</sup> This test method is under the jurisdiction of ASTM Committee D02 on Petroleum Products, Liquid Fuels, and Lubricants and is the direct responsibility of Subcommittee D02.L0.05 on Solid Lubricants.

Current edition approved March 1, 2010. Published April 2010. Originally approved in 1967. Last previous edition approved in 2003 as D2625–94(2003). DOI: 10.1520/D2625-94R10.

<sup>2</sup> For referenced ASTM standards, visit the ASTM website, [www.astm.org](http://www.astm.org), or contact ASTM Customer Service at [service@astm.org](mailto:service@astm.org). For *Annual Book of ASTM Standards* volume information, refer to the standard's Document Summary page on the ASTM website.

<sup>3</sup> Available from Standardization Documents Order Desk, DODSSP, Bldg. 4, Section D, 700 Robbins Ave., Philadelphia, PA 19111-5098, <http://dodssp.daps.dla.mil>.

<sup>4</sup> Available from U.S. Government Printing Office Superintendent of Documents, 732 N. Capitol St., NW, Mail Stop: SDE, Washington, DC 20401, <http://www.access.gpo.gov>.

<sup>5</sup> Trademark of and available from Falex Corp., 1020 Airpark Dr., Sugar Grove, IL 60554. A new model of the Falex Pin and Vee Block Test Machine has been available since 1983. Certain operating procedures are different for this new model. Consult instruction manual of machine for this information. If you are aware of alternative suppliers, please provide this information to ASTM International Headquarters. Your comments will receive careful consideration at a meeting of the responsible technical committee,<sup>1</sup> which you may attend.

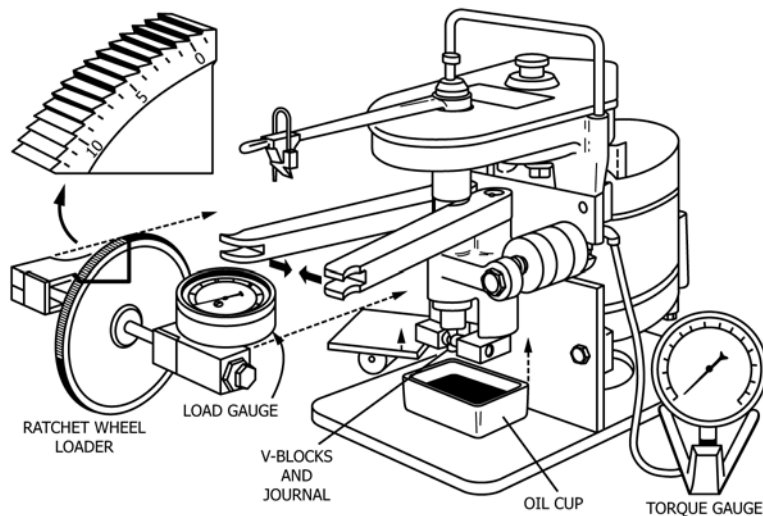

FIG. 1 Schematic Diagram of Falex Pin and Vee Block Test Machine

3.2.4 *load carrying capacity*—the highest indicated load sustained for a minimum of 1 min.

#### 4. Summary of Test Method

4.1 The endurance test (Procedure A) consists of running two stationary steel vee block specimens loaded to a predetermined value against a rotating steel pin specimen. The endurance (wear) life is determined when the torque increases by 10 in-lbf (1.13 N·m).

4.2 The load-carrying capacity test (Procedure B) consists of running two stationary steel vee block specimens against a rotating steel pin, increasing the load on the pin until a sharp increase (10 in-lbf (1.13 N·m)) in steady-state torque or pin breakage is experienced. Prior to both tests, the solid film lubricant is deposited on the surfaces of the test specimens.

#### 5. Significance and Use

5.1 This test method differentiates between bonded solid lubricants with respect to their wear life and load-carrying capacity. If the test conditions are changed, wear life may change and relative ratings of the bonded solid film lubricants may be different.

#### 6. Apparatus

6.1 *Falex Pin and Vee Block Test Machine*,<sup>5</sup> illustrated in Fig. 1 and Fig. 2.

6.1.1 *Load Gauge*,<sup>5</sup> 4500-lbf (20 000-N) range, or 3000-lbf (13 300-N) direct-reading gauge. An 800-lbf (3550-N) direct-reading load gauge may be used for Procedure A, but does not have a high enough load range for Procedure B.

NOTE 2—Primary figures for loads are shown for the 4500-lbf (20 000-N) gauge. Equivalent readings on either 800 or 3000-lbf (3550 or 13 300-N) direct-reading gauges are shown in parentheses and can be obtained from the curve in Fig. 3.

6.1.2 *Optional*—An automatic cutoff, torque recorder, and timer may be used in place of the standard indicating torque gauge.

6.2 *Required for Calibration of Load Gauge:*

6.2.1 *Standardized Test Coupon*,<sup>5</sup> soft, annealed copper HB 37/39.

6.2.2 *Allen Screw*,<sup>5</sup> with attached 10-mm Brinell ball.

6.2.3 *Back-up Plug*.<sup>5</sup>

6.2.4 *Brinell Microscope*, or equivalent.

6.2.5 *Rule*, steel, 150 mm (6 in.) long.

6.2.6 *Timer*, graduated in minutes and seconds.

6.3 *Required for Application of Dry Solid Film Lubricants* (see Annex A1):

6.3.1 *Desiccator*, for storing test parts. The bottom of the desiccator shall be filled with desiccant to maintain approximately 50 % relative humidity. (Not required if parts can be stored in a fume-free room at  $50 \pm 5$  % relative humidity.)

6.3.2 *Forced-Circulation Oven*, capable of maintaining a temperature of  $149 \pm 5^\circ\text{C}$  ( $300 \pm 10^\circ\text{F}$ ).

6.3.3 *Micrometer*, reading 0 to  $25 \pm 0.0025$  mm (0 to  $1 \pm 0.0001$  in.), with a one-ball anvil.

6.3.4 *Vapor Degreasing Bath*.

#### 7. Reagents and Materials

7.1 *Required for Procedures A and B:*

7.1.1 *Eight Standard Vee Blocks*,<sup>5</sup>  $96 \pm 1^\circ$  angle, heat treated to  $1.24 \times 10^9$  to  $1.38 \times 10^9$  Pa (180 000 to 200 000 psi) tensile strength; or standard coined vee blocks,  $96 \pm 1^\circ$  angle, of AISI C-1137 steel as an alternative, with a Rockwell hardness of HRC 20 to 24 and surface finish of  $1.3 \times 10^{-7}$  to  $2.5 \times 10^{-7}$  m (5 to 10  $\mu\text{in.}$ ), rms.

7.1.2 *Four Standard Test Pins*,<sup>5</sup> 6.35-mm ( $1/4$ -in.) outside diameter by 31.75 mm ( $1 1/4$  in.) long, heat treated to  $1.24 \times 10^9$  to  $1.38 \times 10^9$  Pa (180 000 to 200 000 psi) ultimate hardness; or Standard No. 8 Pins of AISI 3135 steel as an alternative, with a hardness of HRB 87 to 91, on a ground, flat surface (or approximately HRB 80 to 83 on the round), and a surface finish of  $1.3 \times 10^{-7}$  to  $2.5 \times 10^{-7}$  m (5 to 10  $\mu\text{in.}$ ) rms.

7.1.3 *Locking (Shear) Pin*,<sup>5</sup>  $1/2$  H Brass, conforming to Specification B16/B16M.

7.2 *Required for Application of Dry Solid Film Lubricant* (see Annex A1):

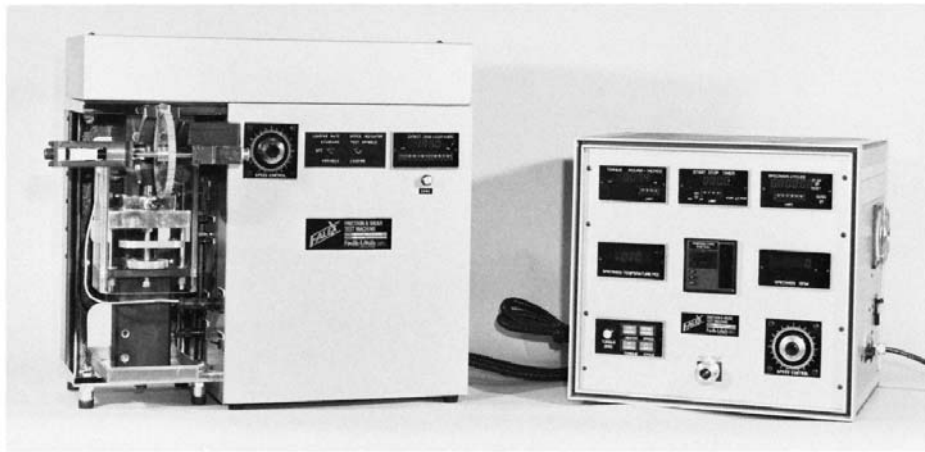

FIG. 1 Digital Pin and Vee Block Test Machine (continued)

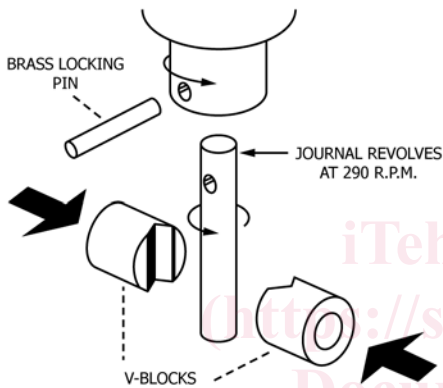

FIG. 2 Exploded View of Vee Blocks and Journal Arrangement, Falex Pin and Vee Block Test Machine

7.2.1 *Phosphate Coating*, manganese, conforming to Military Specification MIL-P-16232F, Type M, Class 3 controlled to a coating weight of 16 to 22 g/m<sup>2</sup>.

NOTE 3—Lack of rigid control of the phosphate coating weight can significantly impact the data scatter. A film controlled to the minimum range is preferred over the uncontrolled standard heavy phosphate originally called out.

7.2.2 *Cleaners*—Select a cleaning media and method which is safe, non-film forming and which does not in any way attack or etch the surface chemically. In addition, no Class 1 ozone depleting substances conforming to Section 602(a) of the Clean Air Act Amendments of 1990 (42USC7671a) as identified in Section 326 of PL 102-484 should be used. Use a procedure as outlined in Test Method F22 to judge the merit of the selected cleaning technique.

NOTE 4—A typical solvent found acceptable for this purpose is Stoddard solvent.

7.2.2.1 No method of cleaning can be judged as acceptable unless there is a valid method of judging the success or failure of the cleaning method. Test Method F22 is a simple procedure that can be used on the actual test apparatus or on test coupons to judge each cleaning method's viability.

7.2.3 *Aluminum Oxide*, white angular abrasive, 180 grit to 220 grit.

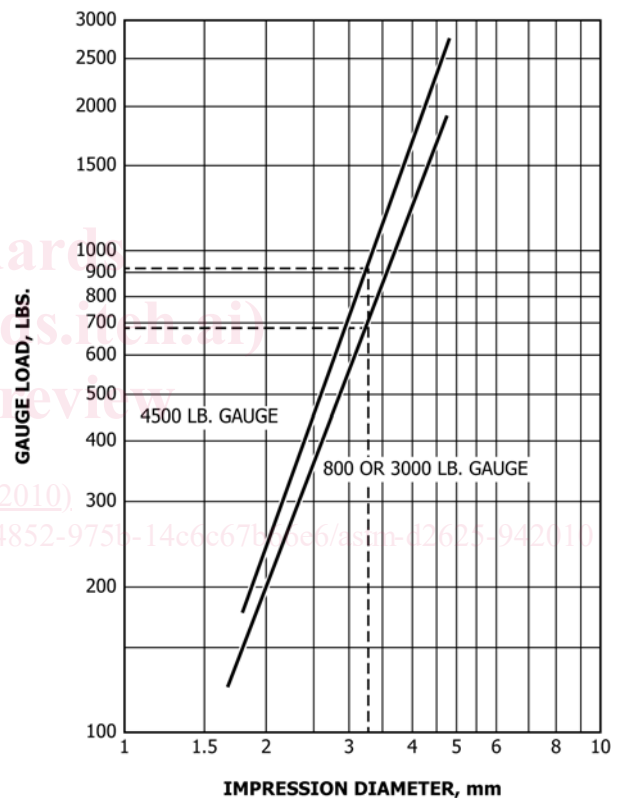

FIG. 3 Standard Curves for Load Gauge Calibration or Conversion, Brinell Impression Diameter versus Gauge Load Reading, Using Standard Copper Test Coupon of HB 37/39

## 8. Preparation of Apparatus

8.1 Thoroughly clean the jaw supports for the vee blocks and test journals, by washing with the solvent selected from 7.2.2, of all debris or oil from previous test runs. See Note 4.

8.2 Avoid contact with the fingers of the mating surfaces of the vee blocks and test pins.

8.3 Avoid atmospheric contamination such as cigarette smoke, as this can adversely affect the test results.