Paints and varnishes — Scratch test using a spring-loaded pen

*Peintures et vernis — Essai de rayage manuel utilisant un barreau
d'essai de dureté*

iTeh STANDARD PREVIEW
(standards.iteh.ai)

[ISO 22557:2019](https://standards.iteh.ai/catalog/standards/sist/4a95d7a4-a611-454d-930b-ded61549c51c/iso-22557-2019)

[https://standards.iteh.ai/catalog/standards/sist/4a95d7a4-a611-454d-930b-
ded61549c51c/iso-22557-2019](https://standards.iteh.ai/catalog/standards/sist/4a95d7a4-a611-454d-930b-ded61549c51c/iso-22557-2019)



iTeh STANDARD PREVIEW (standards.iteh.ai)

ISO 22557:2019

<https://standards.iteh.ai/catalog/standards/sist/4a95d7a4-a611-454d-930b-ded61549c51c/iso-22557-2019>



COPYRIGHT PROTECTED DOCUMENT

© ISO 2019

All rights reserved. Unless otherwise specified, or required in the context of its implementation, no part of this publication may be reproduced or utilized otherwise in any form or by any means, electronic or mechanical, including photocopying, or posting on the internet or an intranet, without prior written permission. Permission can be requested from either ISO at the address below or ISO's member body in the country of the requester.

ISO copyright office
CP 401 • Ch. de Blandonnet 8
CH-1214 Vernier, Geneva
Phone: +41 22 749 01 11
Fax: +41 22 749 09 47
Email: copyright@iso.org
Website: www.iso.org

Published in Switzerland

Contents

	Page
Foreword.....	iv
1 Scope	1
2 Normative references	1
3 Terms and definitions	1
4 Principle	2
5 Apparatus	2
6 Test specimens	6
6.1 General requirements.....	6
6.2 Film thickness.....	6
6.3 Conditioning.....	6
7 Procedure	7
7.1 Agreements.....	7
7.2 Test conditions.....	7
7.3 General test procedure.....	7
7.4 Constant test load method (test requirement I – “pass/fail” test).....	7
7.5 Varied test load method (test requirement II – classification test).....	7
7.6 Assessment of the damage.....	8
8 Precision	9
8.1 General.....	9
8.2 Repeatability limit, r	9
8.3 Reproducibility limit, R	9
9 Test report	9
9.1 Detailed form.....	9
9.2 Short form.....	10
Annex A (informative) Details on the interlaboratory comparison for the estimation precision	11
Bibliography	15

Foreword

ISO (the International Organization for Standardization) is a worldwide federation of national standards bodies (ISO member bodies). The work of preparing International Standards is normally carried out through ISO technical committees. Each member body interested in a subject for which a technical committee has been established has the right to be represented on that committee. International organizations, governmental and non-governmental, in liaison with ISO, also take part in the work. ISO collaborates closely with the International Electrotechnical Commission (IEC) on all matters of electrotechnical standardization.

The procedures used to develop this document and those intended for its further maintenance are described in the ISO/IEC Directives, Part 1. In particular, the different approval criteria needed for the different types of ISO documents should be noted. This document was drafted in accordance with the editorial rules of the ISO/IEC Directives, Part 2 (see www.iso.org/directives).

Attention is drawn to the possibility that some of the elements of this document may be the subject of patent rights. ISO shall not be held responsible for identifying any or all such patent rights. Details of any patent rights identified during the development of the document will be in the Introduction and/or on the ISO list of patent declarations received (see www.iso.org/patents).

Any trade name used in this document is information given for the convenience of users and does not constitute an endorsement.

For an explanation of the voluntary nature of standards, the meaning of ISO specific terms and expressions related to conformity assessment, as well as information about ISO's adherence to the World Trade Organization (WTO) principles in the Technical Barriers to Trade (TBT) see www.iso.org/iso/foreword.html.

This document was prepared by Technical Committee ISO/TC 35, *Paints and varnishes*, Subcommittee SC 9, *General test methods for paints and varnishes*.

Any feedback or questions on this document should be directed to the user's national standards body. A complete listing of these bodies can be found at www.iso.org/members.html.

Paints and varnishes — Scratch test using a spring-loaded pen

1 Scope

This document specifies a method for determining the resistance of a coating to scratches introduced by a usually hand-held loaded stylus.

The test can be carried out using a point stylus (method A) or using a disc stylus (method B).

Both methods are generally applicable and can be used in the field as well as on curved surfaces. Method A can also be applied on small test specimens (minimum dimensions 30 mm × 50 mm).

The test can be carried out as a “pass/fail” test (test requirement I) or as a classification test (test requirement II).

2 Normative references

The following documents are referred to in the text in such a way that some or all of their content constitutes requirements of this document. For dated references, only the edition cited applies. For undated references, the latest edition of the referenced document (including any amendments) applies.

ISO 868, *Plastics and ebonite — Determination of indentation hardness by means of a durometer (Shore hardness)*

ISO 2808, *Paints and varnishes — Determination of film thickness*

ISO 4618, *Paints and varnishes — Terms and definitions*

ISO 13076, *Paints and varnishes — Lighting and procedure for visual assessments of coatings*

ISO 14526-1, *Plastics — Phenolic powder moulding compounds (PF-PMCs) — Part 1: Designation system and basis for specifications*

CEN/TS 13388, *Copper and copper alloys — Compendium of compositions and products*

EN 10027-2, *Designation systems for steels — Part 2: Numerical system*

3 Terms and definitions

For the purposes of this document, the terms and definitions given in ISO 4618 and the following apply.

ISO and IEC maintain terminological databases for use in standardization at the following addresses:

- ISO Online browsing platform: available at <https://www.iso.org/obp>
- IEC Electropedia: available at <http://www.electropedia.org/>

3.1

stylus

scratching tool with specified geometry

3.2

writing effect

smoothing of the surface profile of a coating by impact of a loaded *stylus* (3.1) being moved over the surface

3.3
writing mark
gash

scratch with continuous *writing effect* (3.2) damage

3.4
metal marking

writing mark (3.3) which is introduced with a metal *stylus* (3.1) and covered with abraded stylus material

4 Principle

A stylus loaded with a test load between 0,5 N to 20 N is manually moved over the coating surface. The so introduced damage is visually (magnifier) examined and assessed.

The test can be carried out as method A using a point stylus (diameter 0,50 mm, 0,75 mm, or 1,00 mm) or as method B using a disc stylus (made of stainless steel, copper, thermoset, or PMMA [Polymethyl methacrylate]).

5 Apparatus

5.1 Hardness pen, as illustrated in [Figures 1](#) and [2](#), with the following properties:

5.1.1 The pressure spring, which is compressed by the locking slider, generates the test load exerting on the stylus. This test load can be read in newtons by means of the slider position on the scale.

In order not to change the elastic behaviour of the spring, it shall be relaxed in case the hardness pen is not in use for any length of time.

<https://standards.iteh.ai/catalog/standards/sist/4a95d7a4-a611-454d-930b-d61549051c1e/iso-22557-2019>

5.1.2 The range of the test load shall be between 0,5 N to 20 N.

With regard to common hardness pens test load, ranges between 0,5 N to 3 N (graduation 0,1 N), 1,5 N to 10 N (graduation 0,5 N) and 3 N to 20 N (graduation 1 N) are available by means of exchangeable pressure springs.

Due to the non-linearity of the spring characteristics and the friction within the hardness pen, the specified lower limits of the test load ranges shall not be underrun.

5.1.3 The removable head piece is the guide bush for the point stylus or the test disc holder respectively. The test load, set by means of the slider, is effective if

- for the apparatus in accordance with [Figure 1](#), the point stylus is pushed into the head piece so that only the tungsten-carbide insert protrudes, and if
- for the apparatus in accordance with [Figure 2](#), the test disc is pushed into the head piece so that both supporting wheels touch the counter surface.

NOTE For the apparatus in accordance with [Figure 1](#), scratches might be introduced unintentionally by the head piece. These scratches hinder the evaluation of the test. Therefore, head piece options with supporting wheels are also available (see [Figure 3](#)).

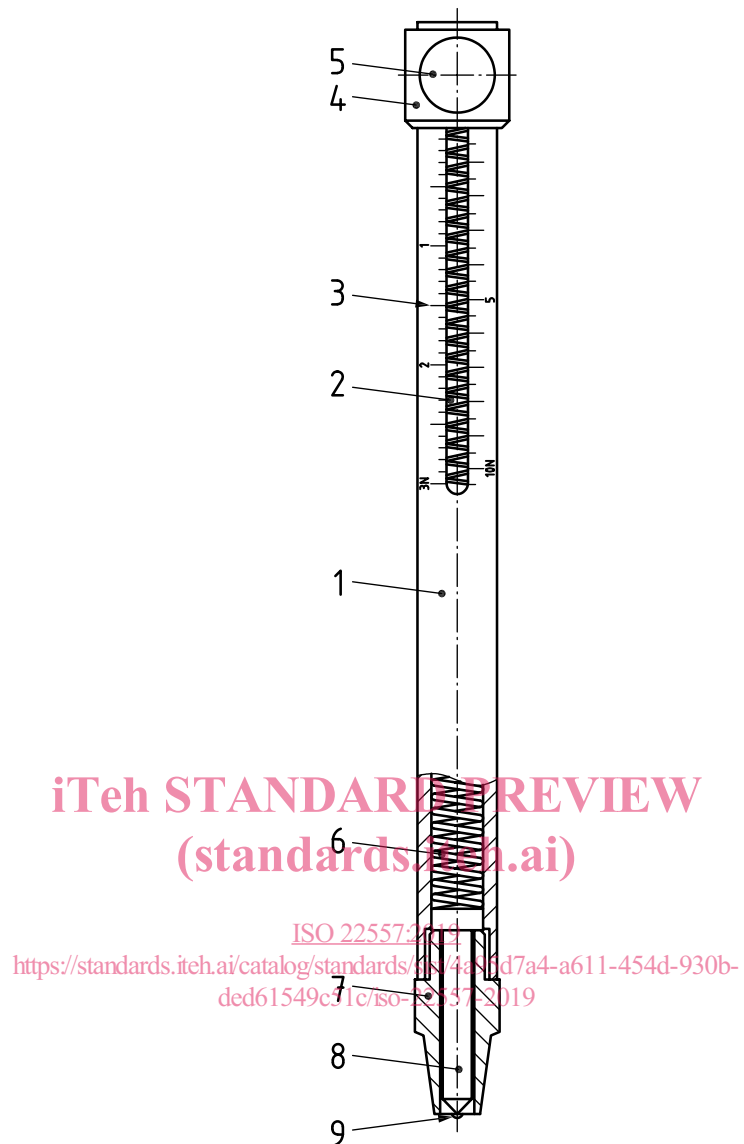
**Key**

- 1 metal sleeve
- 2 slot
- 3 scale (test load)
- 4 slider
- 5 locking screw
- 6 pressure spring
- 7 head piece
- 8 point stylus with (9)
- 9 spherical tungsten-carbide insert

Figure 1 — Hardness pen — Apparatus for method A

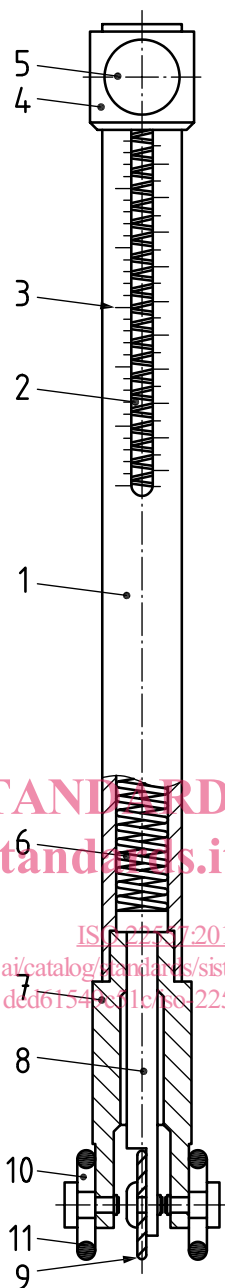

iTeh STANDARD PREVIEW
(standards.iteh.ai)

ISO 22557:2019
<https://standards.iteh.ai/catalog/standards/sist/4a95d7a4-a611-454d-930b-dcd6154271b/iso-22557-2019>

Key

- | | |
|---------------------|---|
| 1 metal sleeve | 7 head piece |
| 2 slot | 8 disc stylus, consisting of test disc holder and (9) |
| 3 scale (test load) | 9 test disc |
| 4 slider | 10 supporting wheel |
| 5 locking screw | 11 rubber O-ring |
| 6 pressure spring | |

Figure 2 — Hardness pen — Apparatus for method B

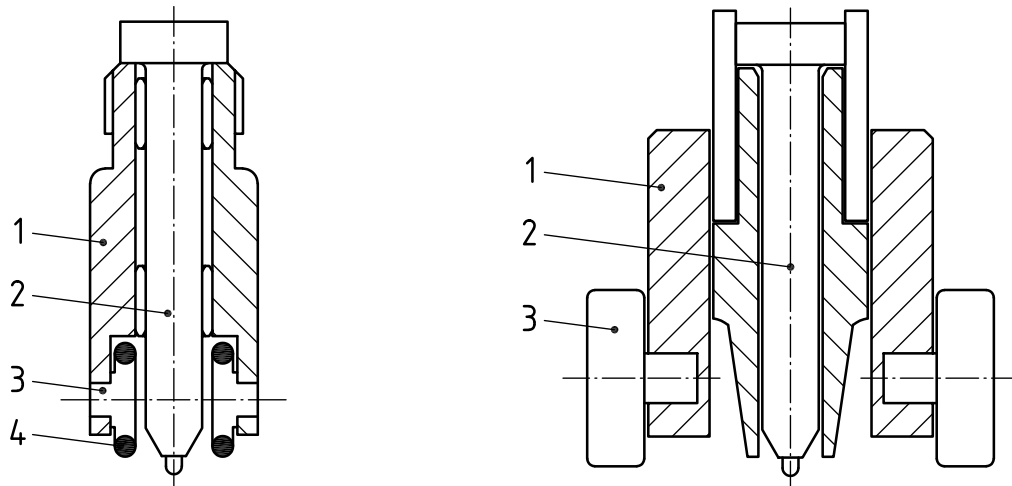

Key

- 1 shank of the head piece with slideway
- 2 point stylus
- 3 supporting wheel
- 4 rubber O-ring

Figure 3 — Head piece for method A — Two common apparatuses with supporting wheels

iTech STANDARD PREVIEW
(standards.iteh.ai)

5.2 Styli.

5.2.1 Styli for method A (point styli): Bolt (shape see [Figure 3](#), key 2) with a spherical tungsten-carbide insert. <https://standards.iteh.ai/catalog/standards/sist/4a95d7a4-a611-454d-930b-ded61549c51c/iso-22557-2019>

5.2.1.1 Stylus A1, with a diameter of $(0,50 \pm 0,01)$ mm.

5.2.1.2 Stylus A2, with a diameter of $(0,75 \pm 0,01)$ mm.

5.2.1.3 Stylus A3, with a diameter of $(1,00 \pm 0,01)$ mm.

5.2.2 Styli for method B (disc styli): Disc with polished edge and with the dimensions in accordance with [Figure 4](#).

NOTE The test disc is screwed to the test disc holder so that it can be used several times by rotating it along the periphery. Test discs with segment marking are also available in order to simplify multiple uses.

5.2.2.1 Stylus B1, shall be made of stainless steel, material 1.4301 or 1.4305 in accordance with EN 10027-2.

5.2.2.2 Stylus B2, shall be made of copper, material 2.0065 (new identification: CW004A) or 2.0090 (new identification: CW024A) in accordance with CEN/TS 13388.

5.2.2.3 Stylus B3, shall be made of thermoset, phenolic resin in accordance with ISO 14526-1, formerly type PF 31.

5.2.2.4 Stylus B4, shall be made of PMMA (polymethyl methacrylate), cast and of hardness 85 Shore D in accordance with ISO 868.

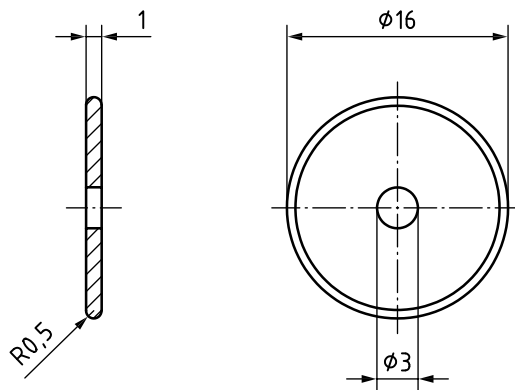

Figure 4 — Dimensions of the test disc (method B)

5.2.3 Application purposes of the styli.

The application purposes of the styli are given in Table 1.

Table 1 — Application purposes of the styli

Stylus type	Stylus material	Application requirement
Point stylus	Tungsten carbide	Mar resistance
Disc stylus	Stainless steel	Resistance to metal marking
	Copper	Resistance to writing effects (“gash resistance”)
	Thermoset	Resistance to writing effects (“fingernail test”)
	Polymethylmethacrylate (PMMA)	Resistance to writing effects (“fingernail test”)

6 Test specimens

6.1 General requirements

For carrying out the measurements, the test specimen may only be touched by the tip of the stylus (and, if applicable, by the supporting wheels), however, not by the head piece of the hardness pen (also see 5.1.3, Note). This criterion shall be especially observed in the case of concavely curved test specimens. For method A, this requirement for the surface shall be fulfilled in an area of minimum 30 mm × 50 mm and for method B, of minimum 50 mm × 150 mm.

6.2 Film thickness

Determine the dry film thickness of the coating, in micrometres, in accordance with one of the methods specified in ISO 2808.

6.3 Conditioning

Prior to testing, condition the coated test panels at a temperature of (23 ± 2) °C and a relative humidity of (50 ± 5) % (see ISO 3270) for a minimum of 16 h, if not otherwise agreed. Carry out the test as quick as possible, however no later than 30 min after the conditioning phase.

7 Procedure

7.1 Agreements

For the procedure of the test, the following shall be agreed:

- the method: A – test with point stylus or B – test with disc stylus;
- the stylus in accordance with 5.2, in accordance with the application requirement (see Table 1);
- the test requirement: either I (“pass/fail” test with constant test load) or II (classification test with varied test load);
- for test requirement II: the test load, in newtons;
- the assessment criterion: e. g. damage when it is first visible, distinct tangible deformation of the coating, cracking of the coating (see Figure 5).

7.2 Test conditions

Carry out the test at a temperature of (23 ± 2) °C. Measure the relative humidity during the test and record it in the test report.

7.3 General test procedure

7.3.1 Insert the agreed stylus and the spring for the intended range of the test load into the hardness pen.

7.3.2 Adjust the intended or agreed test load by means of the slider, then lock it in this position.

7.3.3 Secure the test specimen onto a support, vertically lower down the hardness pen onto the surface and press down in accordance with 5.1.3.

7.3.4 Uniformly move the pressed down hardness pen

- for method A with a speed of about 10 mm/s over a minimum test distance of 10 mm, and
- for method B with a speed of about 100 mm/s over a minimum test distance of 100 mm.

7.3.5 The minimum distance between the test track and the edge of the test specimen shall be 10 mm and the distance to adjacent test track shall be 5 mm.

7.4 Constant test load method (test requirement I – “pass/fail” test)

Carry out scratch tests in triplicate in accordance with 7.3 with the agreed test load. The coating passes the test (“pass”), if the coating is not damaged during each of the three tests. If the coating is damaged during one or several of the three tests, the coating fails the test (“fail”).

7.5 Varied test load method (test requirement II – classification test)

Starting with a test load which does not lead to any damage yet, carry out scratch tests in accordance with 7.3. Successively increase the test load until the coating is damaged for the first time. Repeat this method twice on the same test specimen. Record the lowest final test load, in newtons, from the three determinations as result.